

# Test of Moisture Sensor Activation Speed

I. Parkova, A. Vališevskis, A. Viļumsone

**Abstract**—Nocturnal enuresis or bed-wetting is intermittent incontinence during sleep of children after age 5 that may precipitate wide range of behavioral and developmental problems. One of the non-pharmacological treatment methods is the use of a bed-wetting alarm system. In order to improve comfort conditions of nocturnal enuresis alarm system, modular moisture sensor should be replaced by a textile sensor. In this study behavior and moisture detection speed of woven and sewn sensors were compared by analyzing change in electrical resistance after solution (salt water) was dripped on sensor samples. Material of samples has different structure and yarn location, which affects solution detection rate. Sensor system circuit was designed and two sensor tests were performed: system activation test and false alarm test to determine the sensitivity of the system and activation threshold. Sewn sensor had better result in system's activation test – faster reaction, but woven sensor had better result in system's false alarm test – it was less sensitive to perspiration simulation. After experiments it was found that the optimum switching threshold is 3V in case of 5V input voltage, which provides protection against false alarms, for example – during intensive sweating.

**Keywords**— Conductive yarns, moisture textile sensor.

## I. INTRODUCTION

THE use of wearable sensors for monitoring of various health-related biometric parameters during daily activities has attracted increasing interest recently [1]-[5]. One of wearable sensor types is moisture sensor that measures body fluids like blood, sweat, and urine. Sensors can be used in different fields of application. One of the applications is medicine, where health of patients can be monitored with blood leakage or bedwetting sensors.

In our research sensor is intended for application in nocturnal enuresis alarm system. Nocturnal enuresis or bed-wetting is intermittent incontinence during sleep of children after age five [6] that may precipitate wide range of behavioral and developmental problems. One of the non-pharmacological treatment methods is the use of a bed-wetting alarm system. System consists of moisture sensor and alarm unit. Sensor can be integrated in underwear or in bed sheet. In order to improve comfort conditions of the system, modular hard moisture sensors should be replaced with textile sensors. Based on the analysis of existing nocturnal enuresis alarm systems [7], textile sensors were developed, which contain insulating and electrically conductive textile yarns. Sensor system circuit was designed and two sensor tests were performed: system activation test and false alarm test in order to determine the sensitivity of the system and activation threshold.

I. Parkova, A. Vališevskis, and A. Viļumsone are with Riga Technical University, Institute of Textile Materials Technology and Design, Riga, Latvia (e-mail: inese.parkova@rtu.lv, aleksandrs.valisevskis@rtu.lv, ausma.vilumsone@rtu.lv)

## II. MATERIALS AND METHODS

While designing moisture sensor on textile substrate, its wettability and moisture management are especially important. They have direct impact on speed of sensor signal detection – how fast drops of liquid will be absorbed and will spread through fabric surface, forming contact between the two electrodes. Since moisture sensor is intended for integration into bed sheet or underwear, it is necessary to select appropriate fabric that would be suitable for this application. Usually cotton and linen fiber fabrics are used for bedclothes. Mostly it was provided due to fiber properties: good absorption of water and vapor, good air permeability, good thermal conductivity, influence of rather high temperature is allowed during washing and ironing [8]. Since cotton has good wettability property and it is suitable for bedclothes and underwear application, textile sensor was designed using cotton fabric.

Sewn and woven sensor samples were designed. In these samples conductive yarns (polyamide and copper ply, linear density 330/34 x7 dtex) with electrical resistance 2.3  $\Omega$ /m were used as electrical conductors.

Moisture sensor consists of two single electrodes with a gap between them. Liquid presence is signaled, when there is an electrical connection between the two electrodes induced by the contact with a conductive liquid. Working principle of sensor is shown in Fig.1.

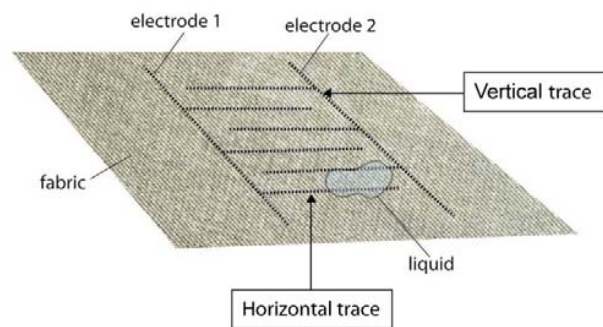

Fig. 1 Working principle of sensor

In the research behavior and moisture detection speed of the designed woven and sewn sensors were compared. In the experiment 0.2 moles of salt per 1 liter of water solution was used, because its conductivity corresponds to the average conductivity of urine [9]. Solution was dripped (4 drops) from drip funnel on sensor, while holding funnel at 5cm distance from horizontal surface of sensor. Experimental set of dripping is adapted from wettability test [10] and is shown in Fig. 2.

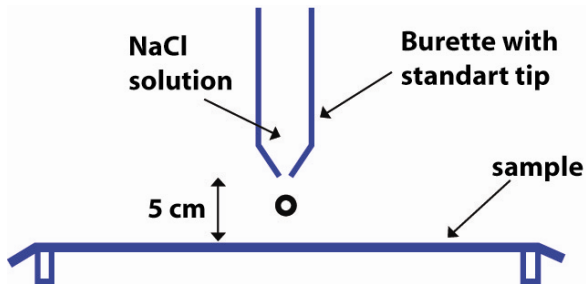

Fig. 2 Experimental set of dripping

Measurements of electrical signals were performed with a digital oscilloscope and data was captured using PicoScope 6 software. With the oscilloscope change of voltage (V) after liquid dripping was determined.

### III. RESULTS AND DISCUSSIONS

In this study change of electrical voltage after solution dripping on woven and sewn samples was analyzed. Experimental set of sensor test is shown in Fig.3. Solution was dripped on the left side of the sensor since in prototype it is purposed to place sensor's left side next to skin. Conductive yarn is placed on sensor's right side.

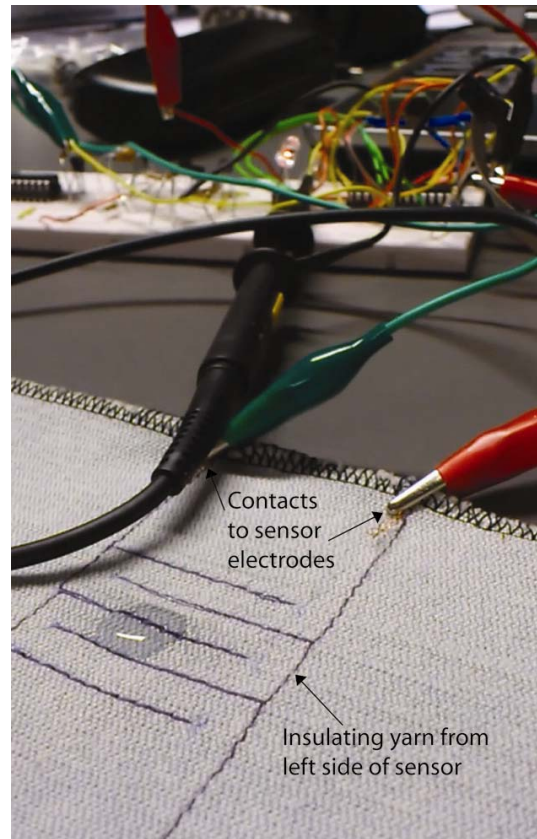

Fig. 3 Experimental set of sensor test: sewn sensor

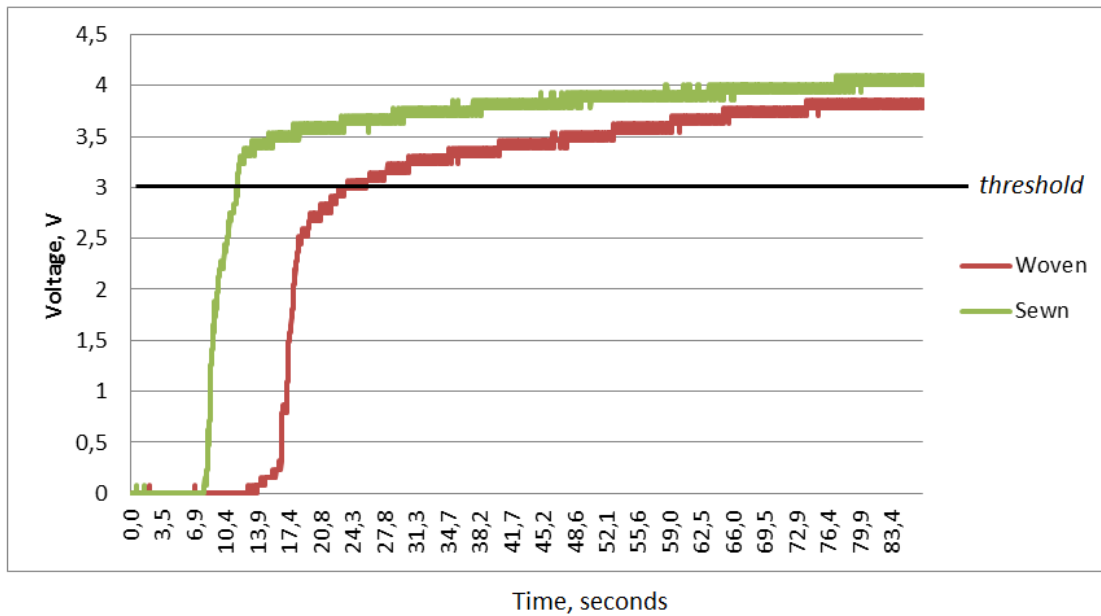

Fig. 4 Results of system activation test

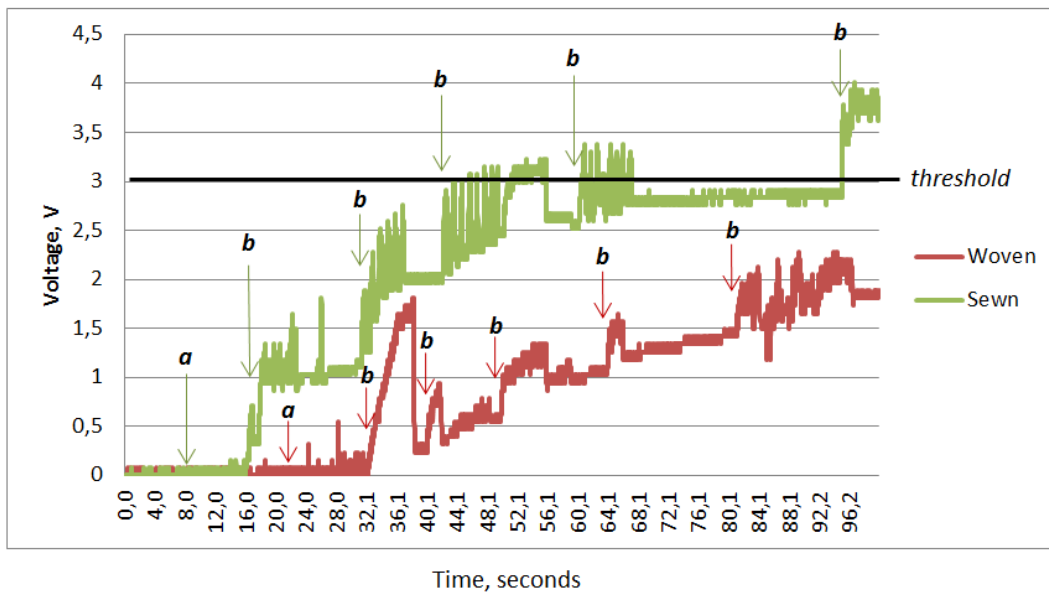

Fig. 5 Results of false alarm test– a: change of voltage during rubbing; b: change of voltage during pressing

Sensor system circuit was designed and two sensor tests were performed: system activation test and false alarm test to determine the sensitivity of the system and activation threshold. Results are shown in Figs. 4 and 5.

As is shown in diagrams sewn and woven samples have different moisture activation speeds – sewn sensor signals faster about moisture presence. Samples have different textile structure and conductive yarn location in fabric that affects moisture activation speed. In woven sample double faced twill weave was used and conductive weft yarn doesn't appear on the left side of fabric, therefore one side of sensor is insulated with cotton yarns. Fabric structure is characterized by the ninth phase, when warp yarns wrap around weft yarns, which are not bent. Wherewith conductive yarn is located between warp systems – it is insulated and makes even surface. In lockstitch seam location (how much it is visible on opposite side of fabric) of conductive yarn (as bobbin yarn) depends from seam balance. It can be affected by yarn tension in sewing machine or yarn linear density. In this case sensor was sewn with balanced seam. Sensors from left side and their magnified views are shown in Fig.6. As can be seen in woven sample (a), conductive yarn doesn't appear on the left side, but in sewn sample (b) loops of conductive yarn appear on the left side of sensor, therefore moisture can reach the conducting surface faster.

False alarm test was performed to determine reaction of sensors during sweating. Sweating conditions were simulated by touching surface of sensors with wet cotton fabric. In diagram (Fig. 5) change of voltage during sensor lightweight rubbing (a) and periodical pressing (b) is shown. During sensor rubbing voltage didn't change significantly, it increased just by pressing sensor.

Goal of the test was to determine the sensitivity of the system and activation threshold. Considering that some pressure of body is possible on sensor because of wearer's movements during sleep, system's activation threshold was set at 3V. System's software have option to vary this threshold – system main board has two buttons that enable one to adjust threshold of system's sensitivity from 1V to 4,5 V in 0,5V steps. Therefore the user has a possibility to adjust sensor's operation according to his/her own physiological particularities.

When alarm goes off, system activates sound signal, LED indicator and vibrator. After wet sensor is disconnected, signals switch off. Circuit of nocturnal enuresis alarm system with LED, buzzer, vibrator, buttons for sensitivity regulation, 2 terminals for sensor connection and 2 terminals for power supply connection is shown in Fig. 7.

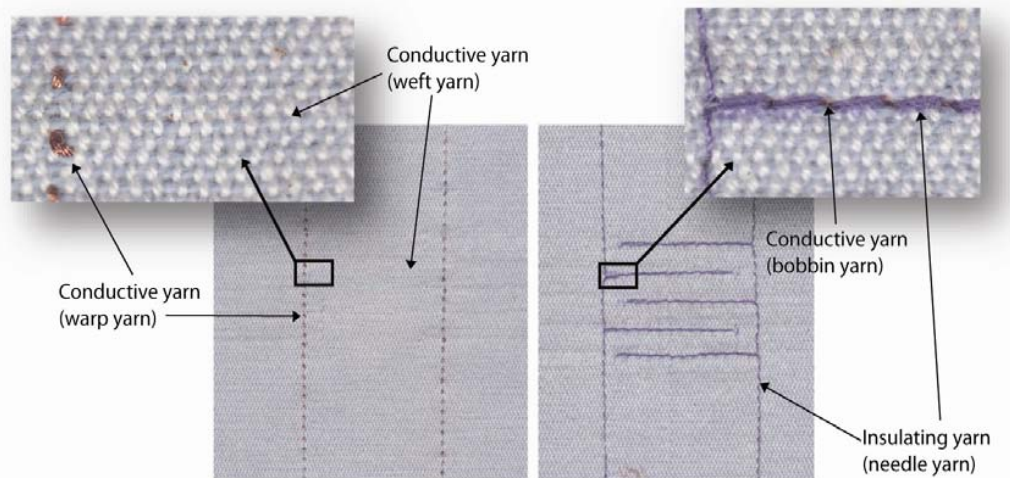

Fig. 6 Samples from left side – a: woven sensor; b: sewn sensor

System runs from 5V power supply. It has two terminals for a textile moisture sensor. The sensor is connected through a voltage divider tuned according to previous studies [11] so that it divides the voltage approximately in half, when the sensor starts to sense conductive liquid. System can be fine-tuned with two buttons, which allow to increase and decrease activation threshold (with default value of 3V). When input signal exceeds threshold value, buzzer, vibrator, and LED turn on intermittently and remain active until input signal decreases.

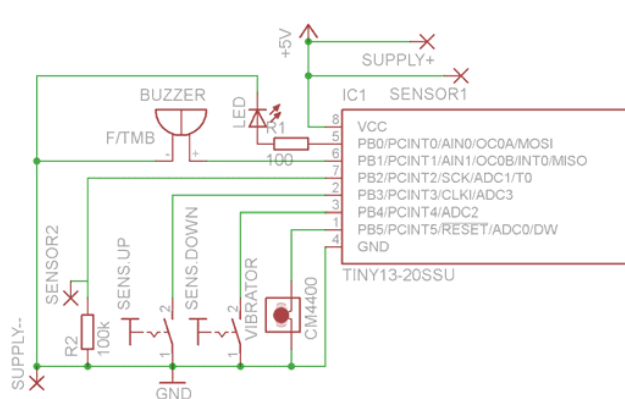

Fig. 7 Circuit of nocturnal enuresis alarm system

#### IV. CONCLUSIONS

When a sensor is integrated into underwear, it is placed close to wearer's body, therefore in order to keep appropriate hygienic and comfort requirements of clothing wear, it is necessary to ensure as small as possible contact surface between electrical conductors (conductive yarns) and wearer's body. However at the same time system's signal detection speed, i.e. time needed for liquid to reach electrically conductive yarns is important as well. In this study signal

detection speed was analyzed, testing samples just from the left side of sensor, where conductive yarns are insulated.

In experiment two types of sensor were considered – sewn and woven sensor. Sewn sensor had better results in system activation test – moisture detection speed was faster, but woven sensor showed better results in false alarm test – it was less sensitive to perspiration simulation. After experiments it was found that the optimum switching threshold is 3V in case of 5V input voltage, which provides protection against false alarms, for example during intensive sweating. Tests were carried out under experimental conditions. In order to examine and compare performance under realistic conditions, it is necessary to perform testing with a user group.

#### ACKNOWLEDGMENT

This work has been supported by the European Social Fund within the projects "Support for the implementation of doctoral studies at Riga Technical University".

#### REFERENCES

- [1] D. Morrisa, S. Coyle, Y. Wu, K.T. Laua, G. Wallace, D. "Diamonda, "Bio-sensing textile based patch with integrated optical detection system for sweat monitoring" in: *Sensors and Actuators B: Chemical*, 139 (1), 2009, pp. 231-236.
- [2] M.A. Mestrovic, "Characterisation and Biomedical application of Fabric Sensors". Australia: RMIT University, 2007. pp 184
- [3] J. Farrington, A. J. Moore, N. Tilbury et al., "Wearable sensor badge and sensor jacket for context awareness" in *Proceedings of ISWC*. San Francisco, 1999, pp 107-113.
- [4] J. Ponmozhi, C. Frias, T. Marques et al., "Smart sensors/actuators for biomedical applications: Review" in *Measurement*. Vol.45, Iss.7, 2012, pp 1675-1688.
- [5] C.R. Merritt, "Electronic Textile-Based Sensors and Systems for Long-Term Health Monitoring/ PhD thesis". North Carolina: ProQuest, 2008, pp 175.
- [6] T. Neveus, P. Eggert, J. Evans, A. Macedo et al., "Evaluation of and Treatment for Monosymptomatic Enuresis: A Standardization Document From the International Children's Continence Society" in *The Journal of Urology*, Vol. 183, Issue 2, 2010, pp 441-447.
- [7] I. Parkova, A. Vališevskis, A. Užāns, A. Viļumsone, "Analysis and Improvement of Nocturnal Enuresis Alarm System" in *Industria Textila*

Magazine, Vol 6, 2013, pp 355-361.

- [8] I. Baltiņa, N. Ozoliņa, "Gultasveļasaudumkvalitāte" in Scientific Journal of RTU. Materiālzinātne. 9. series. 1. vol., 2006, 62-66 lpp.
- [9] Q. A. Acton (ed.). Issues in Genitourinary Medicine: 2011. Scholarly Editions, Atlanta, Georgia, 2012.
- [10] B. P. Saville, Physical Testing of Textiles. Manchester, England: Woodhead Publishing, 1999. –pp 310.
- [11] I. Parkova, "Woven Textile Moisture Sensor for Enuresis Alarm Treatment" in Key Engineering Materials, 2014, vol.604, pp 146-149.

**I.Parkova.** This author got Master's degree in materials design and technology in 2010 at Riga Technical University, Institute of Textile Materials Technology and Design (RTU, TTDI), Riga Latvia. Currently author is a PhD candidate in the same institution. Fields of study include electronic systems integration into clothing, innovative textile materials, smart clothing.

Previously she was working as garment technologist in a production company (LLC Solution) and a scientific assistant in TTDI. At the moment she is working as researcher in TTDI.

Mg. sc.ing.Parkova got Werner von Siemens Excellence Award in 2011 and was included into RTU Golden Fund best student list in 2010.

**A. Vališevskis.** This author got PhD degree in Engineering in 2006 at Riga Technical University, Institute of Information Technology, Riga Latvia. Fields of study include wearable electronics, smart textiles, decision-making under uncertainty, fuzzy systems.

Until 2008 he worked as a leading researcher at Riga Technical University, Faculty of Computer Science and Information technology (RTU, DITF), Riga Latvia. At the moment he is working as a leading researcher at Riga Technical University, Institute of Textile Materials Technology and Design (RTU, TTDI), Riga Latvia.

Dr. Vališevskis got the Charles Babbage Award of the University of Latvia in 2001, The Young Scientist Award of the Latvian Academy of Sciences and JSC Aldaris in 2003 and The Young Scientist Award of the Latvian Academy of Sciences in 2008.

**A. Vījumsone.** This author got PhD degree in textile and clothing technology in 1993 at Riga Technical University, Institute of Textile Materials Technology and Design (RTU, TTDI), Riga Latvia. Fields of study include development and optimization of garment design technological process, CAD/CAM systems in product design, innovative materials and technologies. Previously she was working as pattern designer in Riga Mode House, assistant in TTDI, docent in TTDI. At the moment she is Professor, Head of the Institute of Textile Materials Technologies and Design, Head of the Department of Clothing and Textile Technologies (RTU).