

Study on Liquid Nitrogen Gravity Circulation Loop for Cryopumps in Large Space Simulator

Weiwei Shan, Wenjing Ding, Juan Ning, Chao He, Zijuan Wang

Abstract—Gravity circulation loop for the cryopumps of the space simulator is introduced, and two phase mathematic model of flow heat transfer is analyzed as well. Based on this model, the liquid nitrogen (LN₂) gravity circulation loop including its equipment and layout is designed and has served as LN₂ feeding system for cryopumps in one large space simulator. With the help of control software and human machine interface, this system can be operated flexibly, simply, and automatically under four conditions. When running this system, the results show that the cryopumps can be cooled down and maintained under the required temperature, 120 K.

Keywords—Cryopumps, gravity circulation loop, liquid nitrogen, two-phase.

I. INTRODUCTION

THE cryopump, the critical equipment in the space simulator, should be equipped with LN₂ feeding system to ensure its panel's temperature is below 120 K [1] when it is working. LN₂ feeding system supplies LN₂ for the panel with the required flow rate and the pressure. There are many types of system involved in feeding LN₂ for the cryopump, i.e. tank self-pressurization system, open boiling system and gravity circulation loop system [2]. Tank self-pressurization system should be equipped with two sets of tanks at least, one for supplying LN₂ and the other for recovering LN₂. The merit is that LN₂ can be recycled and reused. However, the installation site of the tank is outside the building which causes the long distance piping, bigger energy loss, and low economic efficiency. As far as the open boiling system is concerned, its piping is relatively easy to design compared with other systems. However, the residual LN₂ in the piping is vented into the atmosphere directly which results in the waste of LN₂ and environmental pollution.

Gravity circulation loop system has much more advantages i.e. convenient operation and maintenance, short distance piping, and lower investment as well. Moreover, subcooler and LN₂ pump are not equipped any more. At the same time, the operating costs are also decreased because of LN₂ recycling. The key to a successful gravity circulation loop system is good accuracy of system designing. Based on the working principle, the core process is LN₂ evaporation and two-phase flow in the

gravity circulation loop. Since the fifties of last century, two phase flow and LN₂ boiling have been studied abroad in terms of theory and experiment research. The research on two phase flow implemented domestically focuses on fundamental theory, power system application and simulation. Because of its special characteristics, the introduction and research on gravity circulation loop have been found in the references from Russia [3], Korea [4]-[6], France [7], Japan and USA [8]-[11], which show that it has been successfully applied and gives us the confidence to carry out its development.

This paper, with the background of one large space simulator, studies the gravity circulation loop and concludes the theoretical simulation method. Based on this method, the gravity circulation system and its piping were designed and developed. The commissioning results were shown at the end of the paper.

II. WORKING PRINCIPLE

The function of gravity circulation loop system is to maintain the temperature of panel in the cryopump below 120 K. Its schematic drawing is shown in Fig. 1. Located in the platform (on top of the vacuum chamber), LN₂ tank supplies LN₂ for the panel through pipeline. LN₂ absorbs the heat and partially vaporizes in the panel. The liquid phase flows back and is recycled into the tank and gaseous phase is vented out.

During the whole circulation, the density difference caused by two phase flow drives the whole flow process. The dynamic pressure head generated by change on void fraction of two phase flow overcomes flow resistance of two-phase flow in the pipeline.

III. THEORETICAL METHOD AND NUMERICAL SIMULATION

A. Two-Phase Flow Heat Transfer Model

LN₂ forced flow boiling model by Kilmenko and Sudarchikov [12] is given as follows: In their experiment, LN₂ boiling happened in a stainless steel pipe of 10 mm diameter and 1850 mm length and its boiling data were measured in both subcooled state and boiling state. The heat transfer formula is given as:

$$\frac{Nu}{Nu_l} = \begin{cases} 1 & Bo < 6 \times 10^4 \\ 0.0041Bo^{0.5} & Bo > 6 \times 10^4 \end{cases} \quad (1)$$

where

$$Nu_l = 0.0042 Pe^{0.6} K_p^{0.5} S^{0.2} \quad (2)$$

Weiwei Shan is with The Beijing Institute of Space Environment Engineering, China (phone: +86-10-68746578-623; fax: +86-10-68746751; e-mail: sww_xjtu@163.com).

Wenjing Ding is with The Beijing Institute of Space Environment Engineering, China (phone: +86-10-68746578-620; fax: +86-10-68746751; e-mail: wjding@163.com).

Juan Ning is with The Beijing Institute of Space Environment Engineering, China (phone: +86-10-68746578; fax: +86-10-68746751; e-mail: swwxjtu@163.com).

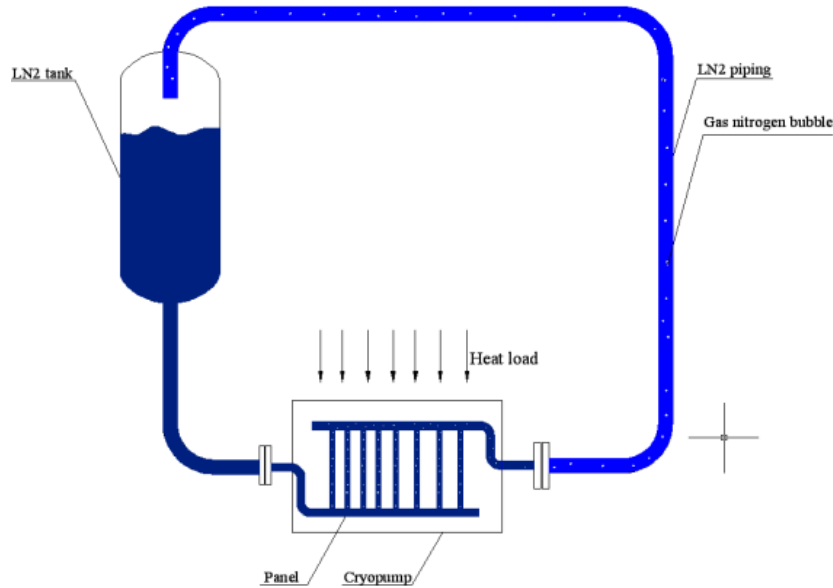

Fig. 1 Schematic drawing of gravity circulation loop system

The criterion number in (2) is as:

$$Bo_* = \frac{rG}{q} \left[1 + x \left(\frac{\rho'}{\rho''} - 1 \right) \right] \quad (3)$$

$$Pe_* = \frac{q[\sigma/g(\rho' - \rho'')]^{1/2}}{r\rho''a} \quad (4)$$

$$K_p = \frac{P}{[\sigma_g(\rho' - \rho'')]^{1/2}} \quad (5)$$

$$S = \frac{(\rho c \lambda)_w}{(\rho c \lambda)'} \quad (6)$$

B. Two-Phase Flow Pressure Drop Model

In gravity circulation loop system, the calculation on pressure loss of two-phase flow is of importance to the successful system operation. The pressure difference between entrance and exit is made up of three parts, which are gravity pressure loss, friction pressure loss and accelerated velocity pressure loss. There are many formula used for two-phase flow, one of which is Martinelli-Chisholm [13]. It fits for small mass flowrate ($G < 1300 \text{ kg}/(\text{m}^2 \cdot \text{s})$). This method calculates the friction pressure loss of two-phase flow based on correcting the apparent single phase friction pressure loss. Four factors called Markov factors are defined. Martinelli number X^2 and Chisholm number Y^2 are defined as well. X^2 is the pressure loss ratio of partial liquid phase to partial gas phase, and Y^2 is the pressure loss ratio of all liquid phase to all gas phase.

$$X^2 = \left(\frac{dp_F}{dz} \right)_l / \left(\frac{dp_F}{dz} \right)_g \quad (7)$$

$$Y^2 = \left(\frac{dp_F}{dz} \right)_{GO} / \left(\frac{dp_F}{dz} \right)_{LO} \quad (8)$$

By relating apparent single-phase friction factor to the above number Martinelli and number Chisholm, we have (9).

$$-\Delta p_F = 4f_{LO} \frac{L}{D} \frac{G^2}{2\rho_l} \left[\frac{1}{x_0} \int_0^{x_0} \Phi_{LO}^2 dz \right] \quad (9)$$

where, Chisholm number is given in (10):

$$\Phi_{LO}^2 = 1 + (Y^2 - 1) \left[Bx^{\frac{2-n}{2}} (1-x)^{\frac{2-n}{2}} + x^{2-n} \right] \quad (10)$$

$$Y^2 = \frac{\rho_l}{\rho_g} \left(\frac{u_g}{u_l} \right)^{0.2} \quad (11)$$

ρ_l, ρ_g are the density of liquid and gas separately.

μ_l, μ_g are viscosity factor of liquid and gas separately.

C. Void Fraction Calculation

In the vertical pipe, each different local void fraction exists along with the position in the length direction. The simplification approach is to consider flow evaporation as subcooling flow and nuclear evaporation by way of combining calculation of bubble point and energy equation. That is to say, from the inlet to the bubble point, the temperature of fluid goes up continually. Beyond the bubble point, it goes into the boiling and heat transfer zone. In this zone, the temperature does not change. The void fraction can be calculated based on the experimental formula given by Klimenko.

From the inlet surface to the calculated surface, the absorbed heat energy is mainly used as the evaporation heat latent, the left part of which is used to increase the velocity. If the absorbed heat energy converts to the latent heat, the formula is given as:

$$\pi l d q = \frac{\pi d^2}{4} r G x \quad (12)$$

where, x is void fraction, L is length, d is pipe's inner diameter, G is surface mass flow rate. Hence, the void fraction can be calculated as:

$$x = \frac{4lq}{drG} \quad (13)$$

IV. SYSTEM DEVELOPMENT

A. System Layout

According to the function requirements, one set of gravity circulation loop system is designed for cryopumps of the large space simulator, which consists of one vertical type tank with 1.2 m^3 , pneumatic valves, temperature sensors, pressure transducers, and piping. The system can realize the four cryopumps' precooling at the beginning and warming up in the end. Depending on the installation height of LN_2 tank, a satisfactory design can realize the whole system running successfully since the relative position of LN_2 tank to the cryopumps affects LN_2 cycling. Based on the symmetrical principle, the horizontal position of the tank is in the middle of four cryopumps, as shown in Fig. 2. The height of the tank is calculated by the simulation software given by [1]. To install the tank in the equipment room successfully, the height of the room must meet the installation requirements of the tank. Moreover, a platform shall be built for supporting the tank in advance.

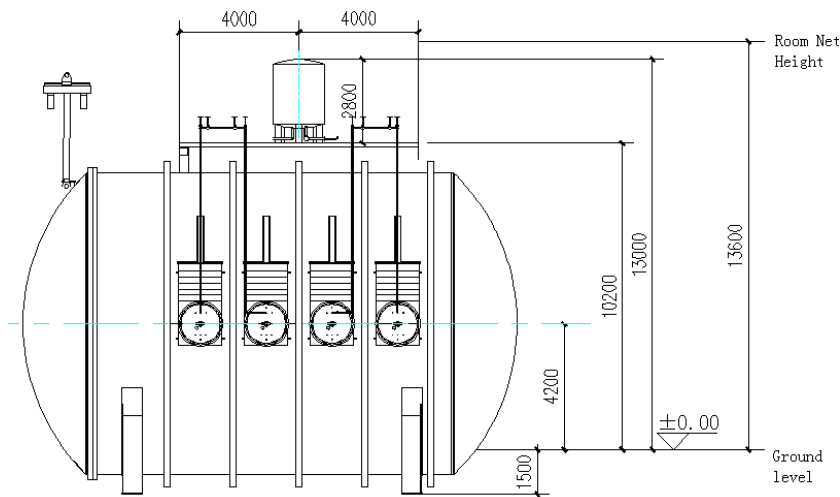

Fig. 2 (a) Layout drawing of gravity circulation loop system in front view

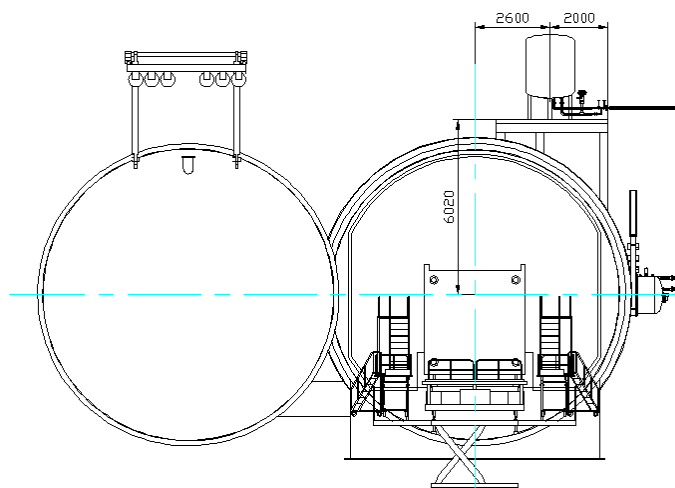

Fig. 2 (b) Layout drawing of gravity circulation loop system in left view

B. System Design

The piping is used to connect between the tank and the cryopump to continuously provide LN₂ for the panel in the cryopump. The operating state of the system is monitored by sensors and transducers, and adjusted by pneumatic valves. To achieve the lowest evaporation rate in LN₂ piping, the cold leakage of LN₂ piping must be controlled and minimized. Therefore, vacuum insulation piping is chosen as LN₂ circulation pipeline.

The structure of vacuum insulation pipe is shown in Fig. 3. This kind of pipe is divided into inner pipe and outer pipe, with the vacuum layer in the middle. The vacuum degree of vacuum insulation pipe is no lower than 1.3×10^{-2} Pa. Surfaces of inner pipe and outer pipe are wrapped by special material to reduce the radiation heat transfer.

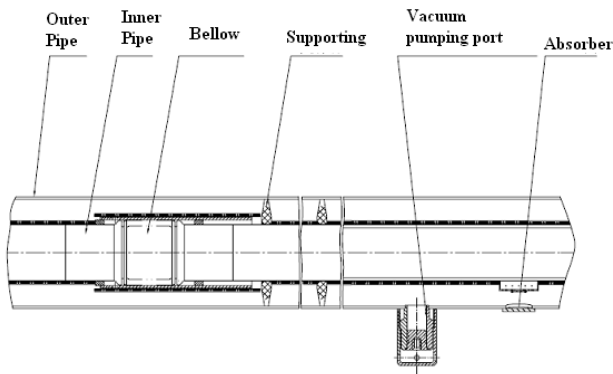

Fig. 3 Structure of vacuum insulation pipe

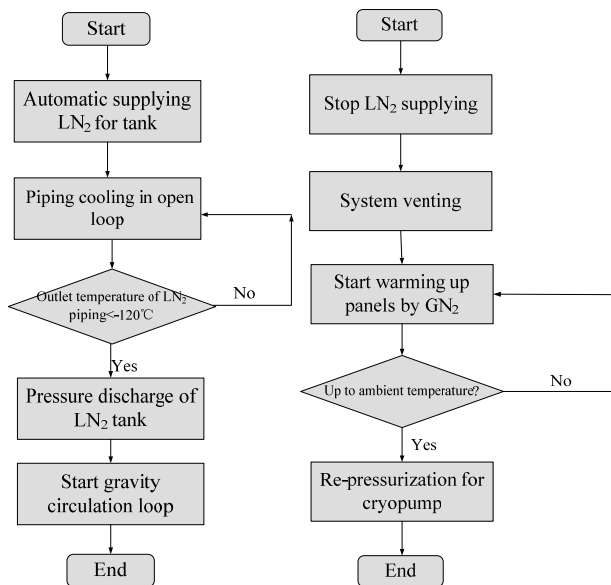

Fig. 4 Control flowchart of LN₂ supplying system for cryopumps

To control and monitor the whole system automatically, pneumatic valves are installed on pipelines and LN₂ tank. Automatic operations involving pressurization, refilling, liquid level control of LN₂ tank can be realized. Moreover, automatic

precooling and warming up of LN₂ panel can be achieved by control software, which saves the human resource effectively and avoid personal incorrect operation. The control flowchart for gravity system is shown in Fig. 4.

C. Operation Mode

Gravity feeding system has different working modes corresponding to different working states of cryopumps, including preparation, precooling and starting.

1. Preparation for Cooling Cryopumps

Since 1.2 m³ LN₂ tank is installed inside the building, feeding lines from LN₂ truck cannot connect to it. Therefore, LN₂ feeding lines are designed to connect 40 m³ LN₂ tank outside and 1.2 m³ LN₂ tank so that LN₂ can be fed to the small tank whenever it is needed. Considering the stable supplying LN₂ for cryopumps, the liquid level of 1.2 m³ tank can be set and maintained at certain value by installing a supplying pneumatic valve. As soon as the tank works, control software automatically adjusts the opening of supplying pneumatic valve to keep the level at 800 mm by PID. The details are as follows: When the level go down to 800 mm, PID gives a command to open the supplying valve. When the level goes up to 900 mm, PID gives a command to close the valve.

2. Cooling Pipeline

At the beginning of precooling cryopump, the temperature of pipelines and LN₂ panel of the cryopump remain the same as room temperature. LN₂ flows into the pipeline and LN₂ panel, and evaporates into gaseous nitrogen. If a large amount of gaseous nitrogen returns to LN₂ tank, it will cause LN₂ boiling in the tank. Hence, gaseous nitrogen is vented outside into atmosphere directly.

3. Working State

Temperature on recovering pipeline should be monitored by temperature sensor. When the value goes down to 120 K, the two phase flow has come out of the cryopumps. Hence, it is time to switch to gravity circulation loop working mode. That is to say, by switching valves, the two phase flow fluid can return to 1.2 m³ tank successfully. At the same time, the temperature of LN₂ panel in the cryopump is maintained in the required temperature range.

4. Warming up

When the cryopumps stop working, cryopumps need to be warmed up to ambient temperature.

V. COMMISSIONING TEST RESULTS AND ANALYSIS

Gravity circulation loop system experienced two tests in all. The control software interface including the flow chart is shown in Fig. 5. Fig. 6 shows the graph of panels' cooling curves in four cryopumps. Fig. 7 shows the graph of panels' warming up curves in four cryopumps. The results show that gravity circulation loop system can cool down four cryopumps to 100 K no longer than 1 hour, and it can warm up four cryopumps from 100 K to 300 K no longer than 1 hour as well. Moreover, the system has the function of automatic supplying

LN₂ and automatic liquid level control of LN₂ tank, which saves the human resources.

VI. CONCLUSION

Coupling the numerical model and practical experiences, gravity circulation loop system has been successfully developed and put into the practical use. Firstly, gravity circulation loop system can cool four sets of cryopumps down to as low as 100 K no longer than 1 hour. Secondly, gravity

circulation loop system can warm up four cryopumps from 100 K to 300 K no longer than 1 hour as well. Finally, the system can ensure four cryopumps are working simultaneously, with the functions of automatic precooling and automatic warming up. All in all, the development of the gravity circulation loop system was successful, of which technology is domestic leading. More importantly, this technology has been applied in many projects.

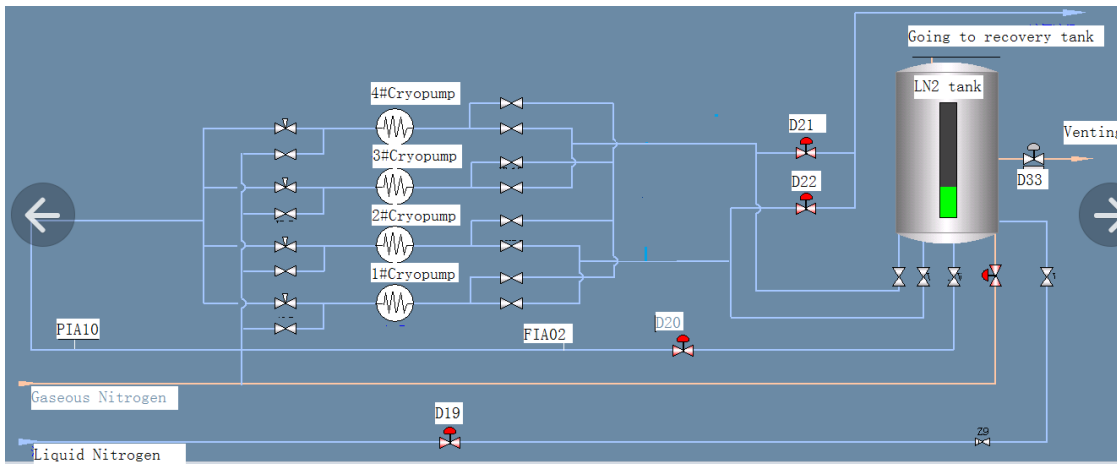

Fig. 5 Control software interface of LN₂ supplying system for cryopumps

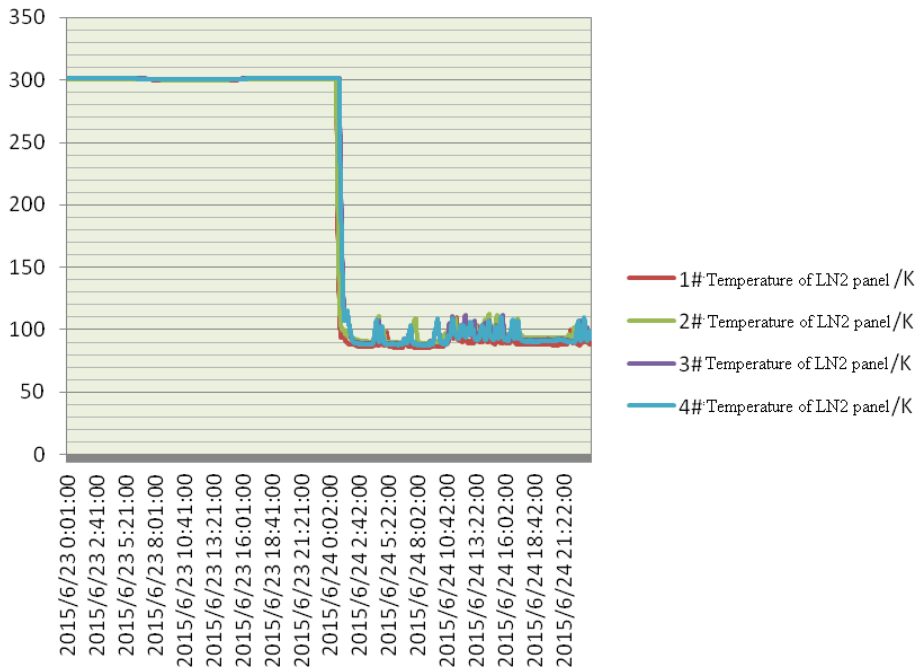

Fig. 6 Cooling down curves of LN₂ panels in cryopumps

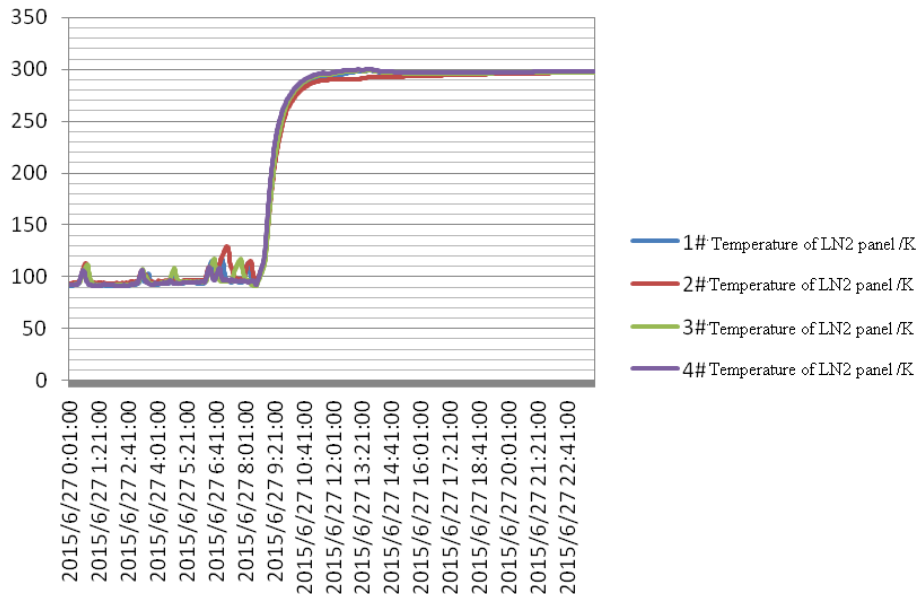

Fig. 7 Warming up curves of LN₂ panels in cryopumps

REFERENCES

- [1] Shanweiwei. A study on the method of nitrogen gravity fed system design. *Spacecraft environment engineering*, 2013, 12.
- [2] Liubotao. Discussion on LN₂ gravity fed system in the space simulator (J). 2003 Cryogenics conference, 2003, 123-127
- [3] DmitriyPodkorytov, Leonid Timkin, Vladimir Chechovich, The investigation of flow characteristics and heat transfer at the nitrogen natural circulation in capillary, *Cryogenics*, Volume 32, Supplement 1, 1992, Pages 316-319.
- [4] Yeon Suk Choi, Ho-Myung Chang, Steven W. Van Sciver, Performance of extended surface from a cryocooler for subcooling liquid nitrogen by natural convection, *Cryogenics*, Volume 46, Issue 5, May 2006, Pages 396-402.
- [5] Kim, M. J., Chang, H. M., Natural circulation loop of subcooled liquid nitrogen, Weisend, JG; Barclay, J; Breon, S; Joint Cryogenic Engineering Conference/International Cryogenic Materials Conference, Chattanooga, TN, Jul 16-20,2007, *Advances in Cryogenic Engineering*, Vols 53A and 53B, AIP Conference Proceedings, 985 2008:59-66.
- [6] Chang, Ho-Myung; Kim, Min-Jee; Sim, Jung Wook, A compact cryocooling system with subcooled liquid nitrogen for small HTS magnets, 20th International Conference on Magnet Technology, Philadelphia, PA, AUG27-31,2007, *IEEE Transactions on Applied Superconductivity*, 2008, 18(2):1479-1482, DOL: 10.1109/TASC.2008.920553.
- [7] Baudouy, B., Experimental study of a nitrogen natural circulation loop at low heat flux, Weisend, JG; Barclay, J; Breon, S; Joint Cryogenic Engineering Conference/International Cryogenic Materials Conference, Tucson, AZ, JUN28-JUL02,2009, *Advances in Cryogenic Engineering*, Vols 55A and 55B, AIP Conference Proceedings, 2010,1218:1546-1553 DOL:10.1063/1.3422335.
- [8] Yu. Ivanov, A. Radovinsky, A. Sasaki, H. Watanabe, T. Kawahara, and S. Yamaguchi, A compact cooling system for HTS power cable based on thermal siphon for circulation of LN₂, AIP Conference Proceedings 1218, 865(2010); doi:10.1063/1.3422441.
- [9] Yamaguchi, Satarou; Ivanov, Yury; Sun, Jian, Experiment of the 200-meter superconducting DC transmission power cable in Chubu University, Kes, PH; Rogalla, H, Superconductivity Centennial Conference (SCC): Hague, Netherlands: Sep18-23,2011: Superconductivity Centennial Conference 2011: *Physics Procedia*, 2012,36:1131-1136 DOI :10.1016/j.phpro.2012.06.189.
- [10] Yury Ivanov, Hirofumi Watanabe, Makoto Hamabe, Toshio Kawahara, Jian Sun, Satarou Yamaguchi, Observation of the thermo siphon effect in the circulation of liquid nitrogen in HTS cable cooling system, *Physics Procedia*, Volume 27,2012, Pages 368-371.
- [11] Hisashi Umekawa, Mamoru Ozawa, Toshiaki Yano, Boiling two-phase heat transfer of LN₂ downward flow in pipe, *Experimental Thermal and Fluid Science*, Volume 26, Issues 6-7, August 2002, Pages 627-633.
- [12] V. V. Klimenko, A. M. Sudarchikov. Investigation of forced flow boiling of nitrogen in a long vertical tube. *Cryogenics*, 1983,23 (7):379-385.
- [13] Luzhongqi. Two-phase flow and boiling heat transfer. Tsinghua press, 2002.

Weiwei Shan: born in P.R. China, 1982, and achieved Master Degree of Cryogenics in Xi'an Jitaotong University, China in 2006. She is working in BISEE in Beijing as a senior engineer.