

Study of the Effect of Soil Compaction and Height on Pipe Ovality for Buried Steel Pipe

Ali Ghodsbini Jahromi, Ehsan Moradi

Abstract—In this paper, the numerical study of buried steel pipe in soil is investigated. Buried pipeline under soil weight, after embankment on the pipe leads to ovality of pipe. In this paper also it is considered the percentage of soil compaction, the soil height on the steel pipe and the external load of a mechanical excavator on the steel pipe and finally, the effect of these on the rate of pipe ovality investigated. Furthermore, the effect of the pipes' thickness on ovality has been investigated. The results show that increasing the percentage of soil compaction has more effect on reducing percentage of ovality, and if the percentage of soil compaction increases, we can use the pipe with less thickness. Finally, ovality rate of the pipe and acceptance criteria of pipe diameter up to yield stress is investigated.

Keywords—Pipe ovality, soil compaction, finite element, pipe thickness

I. INTRODUCTION

SPIRAL pipes are usually used in water transfer projects. In addition to sufficient strength, these types of pipes also exhibit good stability against forces applied to the pipe due to relative flexibility. Pipe thickness significantly affects its behavior against internal and external loads. Besides loads exerted on the pipe, the materials column filling the trench and their compaction play a key role in the rate and mechanism of soil settlement around the pipe. Unequal settlements cause cracks on the ground, damage to the pipe and also channel deformation. The texture of materials filling around the pipe is of great importance because of changes in the geotechnical characteristics of materials during pipe placement in the trench and the role of optimal compaction and material size in determining settlement and load bearing capacity of buried pipes. The interaction of soil and structure includes soil stiffness and pipe hardness, and analyses indicate the greater impact of soil characteristics [1]-[3].

In the study of Psyrras et al. [4], [5], the potential vulnerability of mechanical changes in seismic ground motions on buried pipelines has been investigated. A numerical analysis method was proposed to determine the seismic demand of steel pipelines. The effect of low-frequency ground vibrations on the pipeline was also investigated.

Grigorios et al. [6] studied a steel gas pipeline under large earthquake-induced shear stress leading to buckling failure. Using the results of axial static analysis on some sections of

the gas pipes, the buckling response was discussed and an advanced contact model was used for simulating the pipe-soil relationship.

Bulent et al. [7] studied steel pipes buried along a fault and found that buried pipes are more vulnerable to compressive stress than tensile stress. Thus, pipe orientation angle relative to the fault should be such that a pure stress is applied on the pipe. A numerical study was conducted on a simple model to determine the seismic demand of steel pipes at fault crossings.

There are various definitions for ovality (out of round) in the literature. According to ISO 3162 standard, ovality refers to the percentage difference between the maximum and minimum diameters relative to the nominal diameter. According to API 5L, ovality is defined as the percent difference between the maximum (or minimum) diameter with the nominal diameter relative to the nominal diameter at the same cross section (1).

$$Ovality\% = \frac{MAX(OD) - NOMINAL(OD)}{NOMINAL(OD)} \times 100 \quad (1)$$

Out of round is a common defect which usually occurs in large-diameter pipes and not only causes additional costs, but may even cause product rejection (Fig. 1).

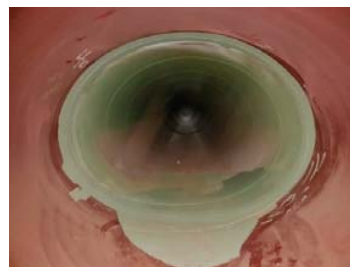

Fig. 1 Ovality of Pipe

Based on pipe dimensions, application and demand, some acceptance limits have been considered for the pipes. Acceptance limit is eventually determined by the employer. Of course, an ovality up to 5% is acceptable (this amounts to 8% in the ASME standard).

Ovality may occur from production stages until operation. Factors such as inappropriate transport of pipes, overload during hydrostatic test, cross weld under inappropriate conditions and material heterogeneity during welding may cause ovality during production.

Ovality may occur after production due to inappropriate transport, piping and after production before operation or even

Ali Ghodsbini Jahromi is with the Mechanical Engineering at Mahab Ghodss Consulting Engineering Company, Tehran, Iran (phone: 00989124095591; e-mail: ali.ghodsbini.j@gmail.com).

Ehsan Moradi is with the Mechanical Engineering at Mahab Ghodss Consulting Engineering Company, Tehran, Iran (phone: 00989183872110; e-mail: msc.emoradi@gmail.com).

during operation because of inappropriate assembly of pipes (inappropriate fit-up causes a permanent pressure), compaction and expansion of the pipeline before being buried, heavy vehicle traffic on the buried pipeline, overload by soil or materials on the pipe caused by inappropriate burying and pipeline displacement by natural factors (flood, earthquake, etc.).

Pipe ovality is an unwanted parameter which should be prevented to avoid time and cost losses. Ovality may lead to difficulty in fit-up and welding operations (which is impossible in some cases), asymmetric pressure distribution during operation and damage to pipe coating [8].

Transfer pipelines are usually buried under the soil. Soil type and the height of soil on the buried pipes have a great impact on the mechanical behavior of pipes. Therefore, it is necessary to study pipe behavior as a function of soil type and soil weight on the pipe to minimize damages to the pipe. To this end, the effects of soil compaction, soil height, pipe thickness and external loads on the pipe caused by a mechanical excavator on the ovality and stresses exerted on the pipe were investigated. The ultimate pipe ovality up to the plastic stress was reported. The steel pipes of type ST52-3 were simulated with the finite element software ABAQUS and the results were discussed.

II. NUMERICAL MODELING

The ovality of water transfer pipelines was numerically studied. Tables I and II, respectively, show pipe characteristics and mechanical properties.

TABLE I
PIPE CHARACTERISTICS

Grade	OD(mm)	t(mm)	L(m)
ST52-3	2438	14.27	12
ST52-3	2438	15.88	12

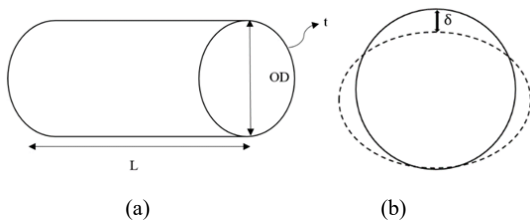

Fig. 2 (a) Schematic of pipe characteristics (b) Vertical displacement

TABLE II
MECHANICAL PROPERTIES

Grade	E(GPa)	Yield(MPa)	ν	ρ (Kgr/m3)
ST52-3	200	358.53	0.3	7800

Simulations were performed with the help of the finite element software, ABAQUS, to investigate the effect of various factors on the ovality of pipes with different thicknesses. Loading was of static type, and shell meshing with four nodes (S4R) was used in the simulations.

A. Ovality Caused by Pipe Weight

The effect of pipe weight of different thicknesses on ovality is discussed in this section. Boundary conditions are as follows: the pipe is placed on a soil with a compaction of 85% with a height of 20 cm (Fig. 3). Given the three-layer polyethylene coating of the pipe, a friction coefficient of 0.18 and 0.13 was considered between the pipe surface and soil, respectively, for a soil compaction of 85% and 80%. Table II lists characteristics of the soil with a compaction of 85% and 80% where C represents soil cohesion, ϕ internal friction angle, ν Poisson's ratio and E is Young's modulus.

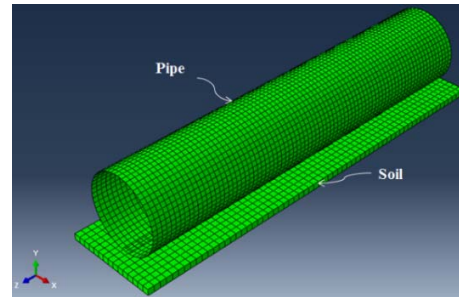
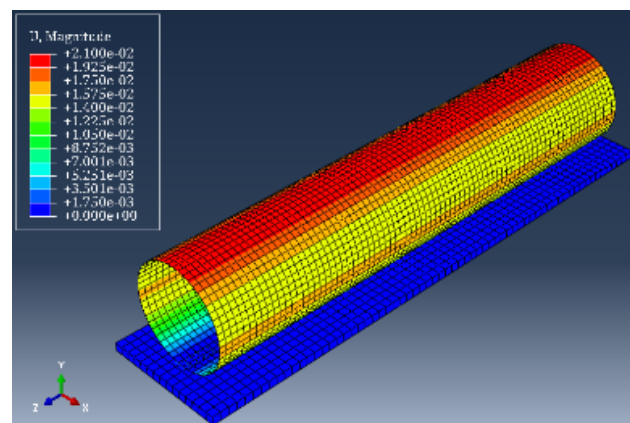

Fig. 3 Pipe place on a soil

TABLE III
CHARACTERISTICS OF THE SOIL

Soil compaction	E (kg/cm2)	Density (Kg/m3)	C (kg/cm2)	ϕ°	ν
80%	4.5	1900	0.1	15	0.35
85%	12	1900	0.2	20	0.35

According to the results on the ovality caused by pipe weight, a maximum vertical displacement (δ) of 2.1 cm and 1.6 cm was obtained for a pipe with a thickness of 14.27 mm and 15.88 mm, respectively. The results are reported in Table IV.



(a)

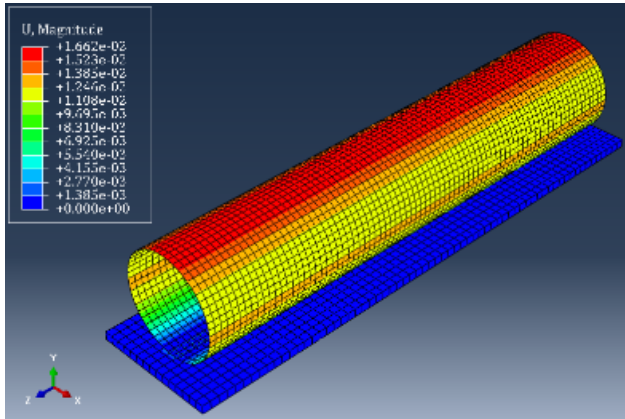

(b)

Fig. 4 (a) Pipe oval with a thickness 14.27 mm (b) Pipe oval with a thickness 15.88 mm

TABLE IV
RESULTS OF OVALITY CAUSED BY PIPE WEIGHT

Thickness (mm)	δ (mm)	Ovality%
14.27	2.1	0.87
15.88	1.6	0.65

B. Effect of Soil Height on Pipe Ovality

The effects of soil height and compaction on the ovality of ST52 pipes with a thickness of 14.27 and 15.88 mm buried under the soil were investigated (Fig. 5). Table III shows mechanical properties of the soil. Soils with a compaction of 80% and 85% were considered and the effect of soil compaction on pipe ovality was evaluated considering the soil height on the buried pipe. The simulation results are discussed below. In the simulated model, the soil height under the pipe (h) is 20 cm, soil width is 3 m, soil length on the pipe is 12 m and four soil heights (H) of 150 cm, 200 cm, 250 cm and 300 cm were considered on the pipe.

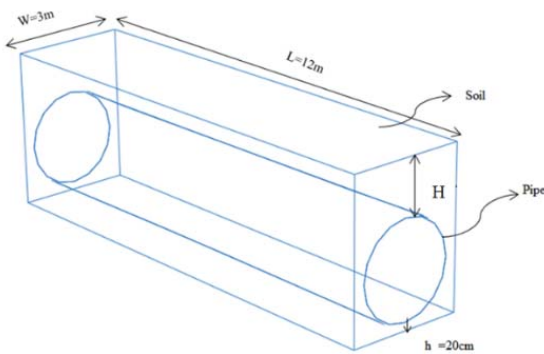
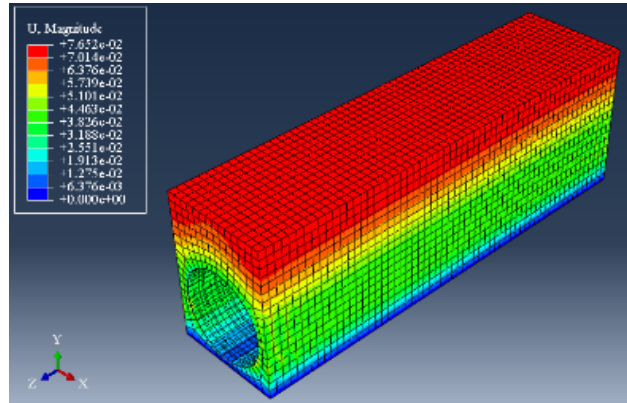

Fig. 5 Pipe buried under the soil

A pipe with a thickness of 14.27 mm buried under the soil with a compaction of 80% was simulated and the effect of soil height on pipe ovality was investigated (Fig. 6). The results are reported in Table V.

TABLE V
RESULTS OF OVALITY DUE EFFECT OF SOIL HEIGHT WITH 80% COMPACTION ON PIPE WITH 14.27 MM THICKNESS

Soil compaction	Material	Thickness (mm)	H (cm)	δ (cm)	Ovality (%)
80%	ST52-3	14.27	150	6.24	2.56
80%	ST52-3	14.27	200	7.70	3.15
80%	ST52-3	14.27	250	9.26	3.80
80%	ST52-3	14.27	300	10.74	4.40



(a) H = 150

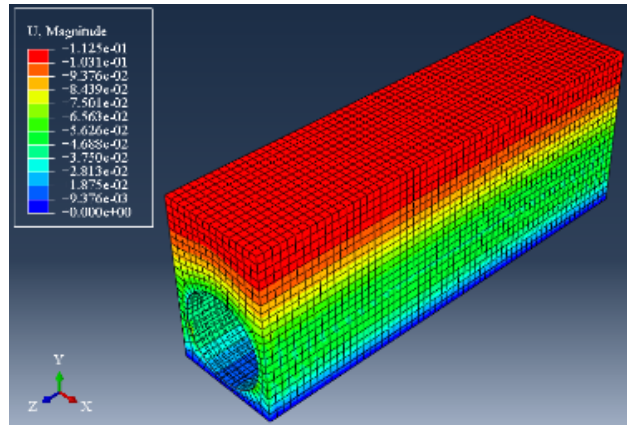

(b) H = 200

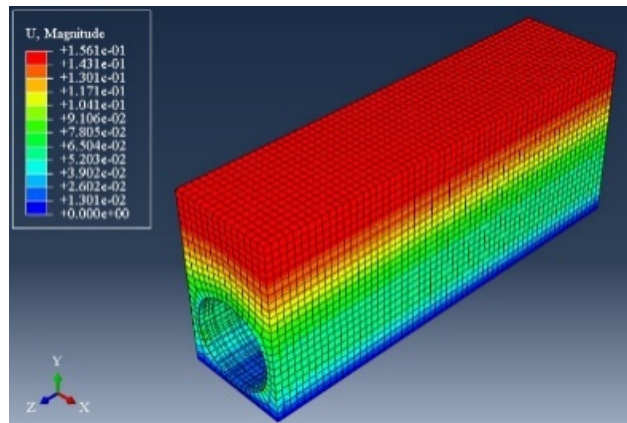

(c) H = 250

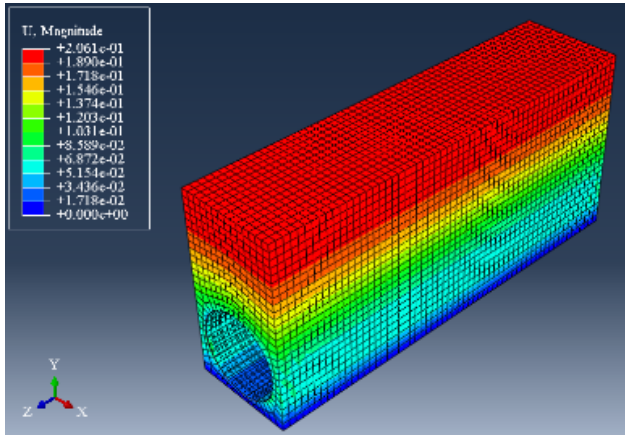

(d) H = 300

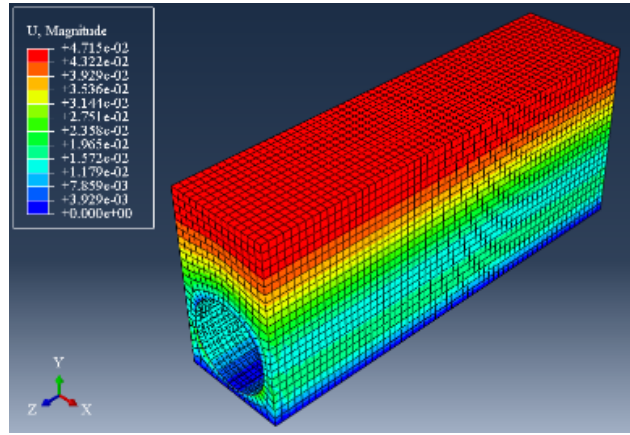

(c) H = 250

Fig. 6 Effect of soil height with 80% compaction on pipe ovality with 14.27 mm thickness

A pipe with a thickness of 14.27 mm buried under the soil with a compaction of 85% was simulated and the effect of soil height on pipe ovality was investigated (Fig. 7). The results are reported in Table VI.

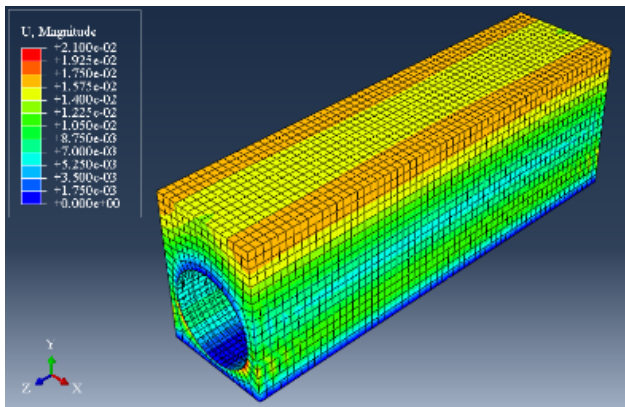

(a) H = 150

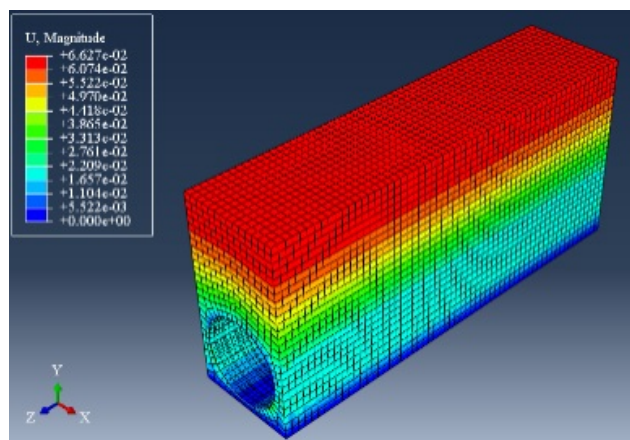

(d) H = 300

Fig. 7 Effect of soil height with 85% compaction on pipe ovality with 14.27 mm thickness

TABLE VI
RESULTS OF OVALITY DUE EFFECT OF SOIL HEIGHT WITH 85% COMPACTION ON PIPE WITH 14.27 MM THICKNESS

Soil compaction	Material	Thickness (mm)	H (cm)	δ (cm)	Ovality (%)
85%	ST52-3	14.27	150	2.77	1.14
85%	ST52-3	14.27	200	3.30	1.35
85%	ST52-3	14.27	250	3.90	1.60
85%	ST52-3	14.27	300	4.50	1.85

A pipe with a thickness of 15.88 mm buried under the soil with a compaction of 80% was simulated and the effect of soil height on pipe ovality was investigated (Fig. 8). The results are reported in Table VII.

TABLE VII
RESULTS OF OVALITY DUE EFFECT OF SOIL HEIGHT WITH 80% COMPACTION ON PIPE WITH 15.88 MM THICKNESS

Soil compaction	Material	Thickness (mm)	H (cm)	δ (cm)	Ovality (%)
80%	ST52-3	15.88	150	5.58	2.29
80%	ST52-3	15.88	200	6.99	2.86
80%	ST52-3	15.88	250	8.42	3.45
80%	ST52-3	15.88	300	9.35	3.83

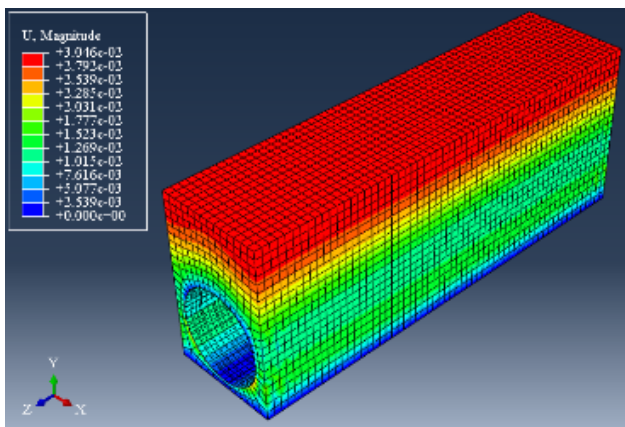

(b) H = 200

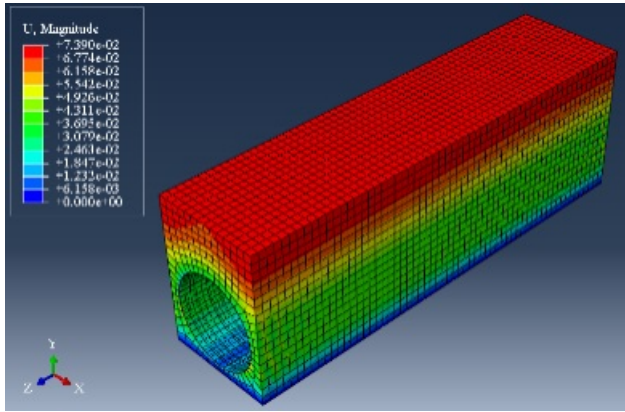

(a) H = 150

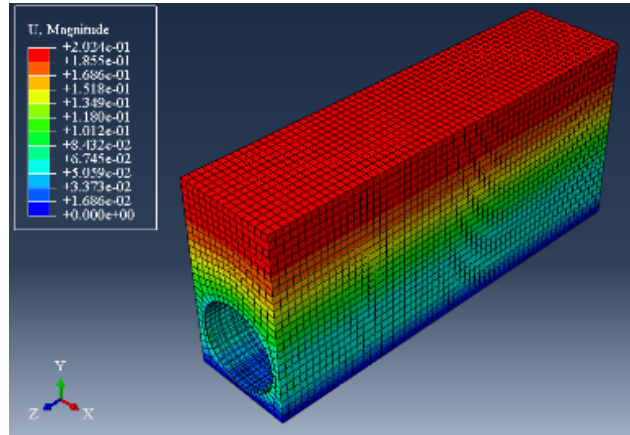

(d) H = 300

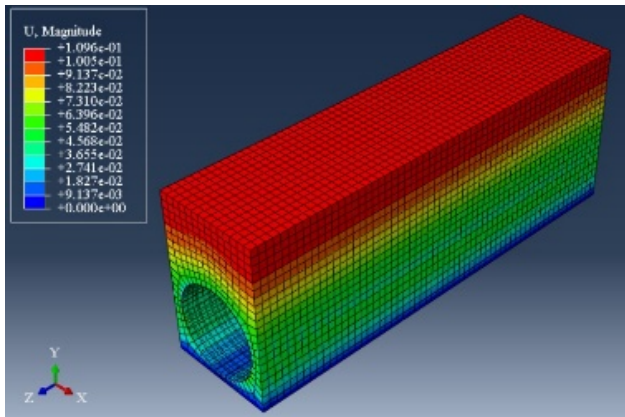

(b) H = 200

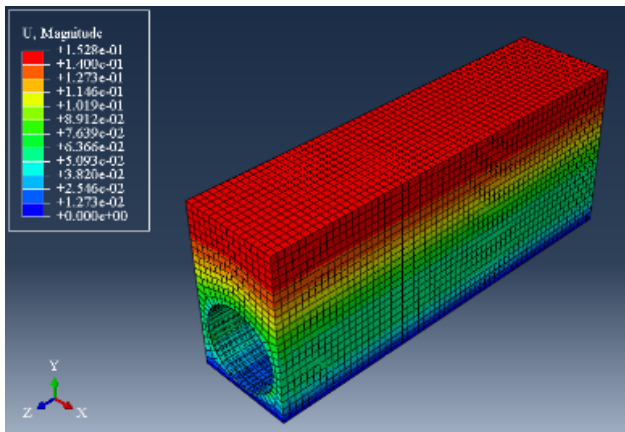

(c) H = 250

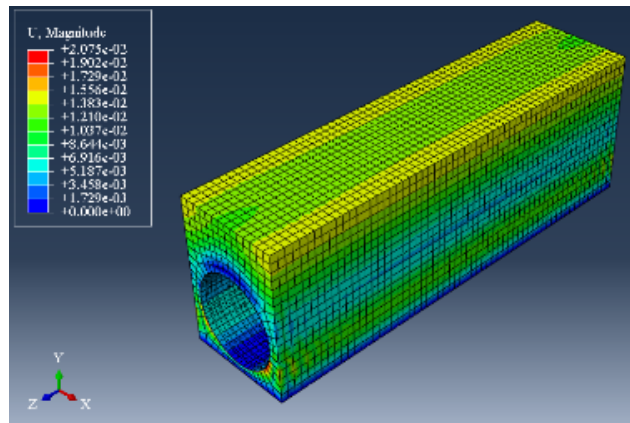

(a) H = 150

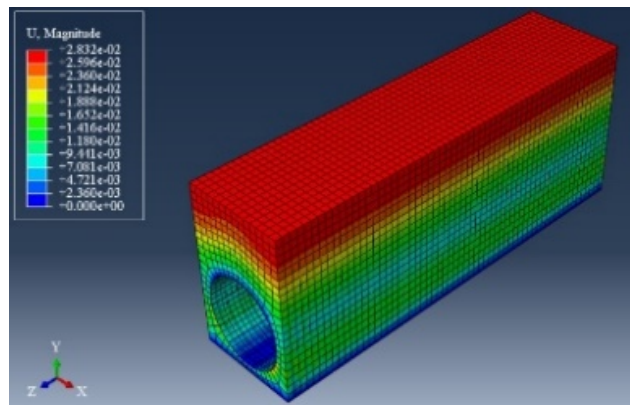

(b) H = 200

Fig. 8 Effect of soil height with 80% compaction on pipe ovality with 15.88 mm thickness

A pipe with a thickness of 15.88 mm buried under the soil with a compaction of 85% was simulated and the effect of soil height on pipe ovality was investigated (Fig. 9). The results are reported in Table VIII.

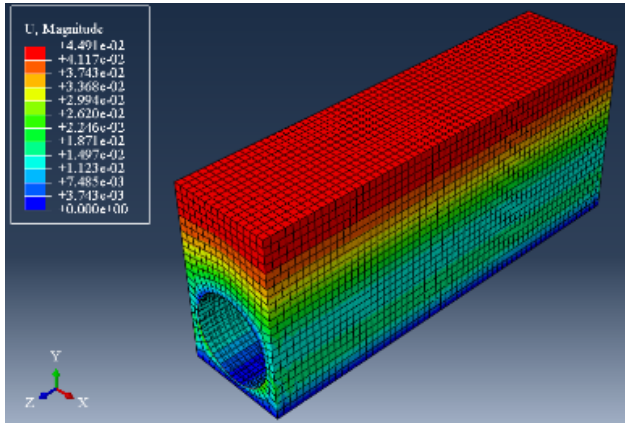

(c) H = 250

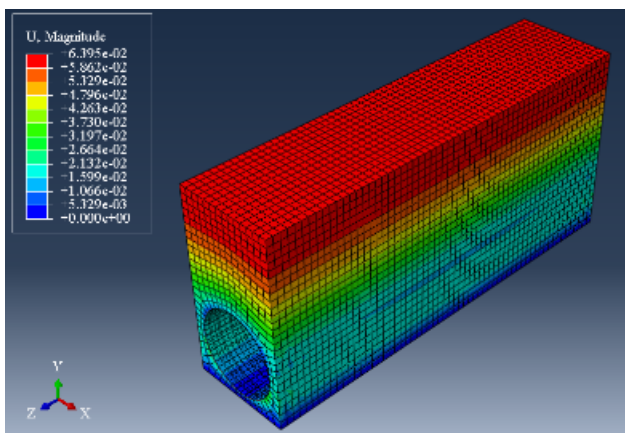

(d) H = 300

Fig. 9 Effect of soil height with 85% compaction on pipe ovality with 15.88 mm thickness

TABLE VIII
RESULTS OF OVALITY DUE EFFECT OF SOIL HEIGHT WITH 85% A COMPACTION ON PIPE WITH 15.88 MM THICKNESS

Soil compaction	Material	Thickness (mm)	H (cm)	δ (cm)	Ovality (%)
85%	ST52-3	15.88	150	2.12	0.87
85%	ST52-3	15.88	200	2.60	1.06
85%	ST52-3	15.88	250	3.18	1.30
85%	ST52-3	15.88	300	3.80	1.55

Table IX shows the results on the effects of soil height and compaction on the ovality and stress exerted on the pipes with a thickness of 14.27 mm and 15.88 mm. As can be seen, an increase in the soil height, and thereby, in the load applied to the pipe, causes an increase in the pipe ovality. An increase in the soil compaction causes a reduction in the ovality of pipes with the same thickness.

Fig. 10 shows ovality of 14.27 mm and 15.88 mm thickness pipes buried under the soil with a compaction of 80% and 85% as a function of soil height. As can be seen, as the compaction of soil on the pipe increases from 80% to 85%, the ovality decreases at a same thickness and soil height. As seen in Fig.

11, 15.88 mm thickness pipes experience a lower ovality than 14.27 mm thickness pipes under the soils with a compaction of 80% and 85% at different soil heights indicating a decrease in the ovality percentage with increasing pipe thickness.

TABLE IX
RESULTS OF OVALITY AND STRESS DUE EFFECT OF SOIL HEIGHT ON PIPE

Soil compaction	Material	Thickness (mm)	H (cm)	δ (cm)	Ovality (%)	Stress(Mpa)
80%	ST52-3	14.27	150	6.24	2.56	78
80%	ST52-3	14.27	200	7.70	3.15	98.1
80%	ST52-3	14.27	250	9.26	3.80	118.2
80%	ST52-3	14.27	300	10.74	4.40	138.5
80%	ST52-3	15.88	150	5.58	2.29	76.6
80%	ST52-3	15.88	200	6.99	2.86	96.9
80%	ST52-3	15.88	250	8.42	3.45	117.4
80%	ST52-3	15.88	300	9.35	3.83	137.9
85%	ST52-3	14.27	150	2.77	1.14	38.1
85%	ST52-3	14.27	200	3.30	1.35	45.6
85%	ST52-3	14.27	250	3.90	1.60	52.6
85%	ST52-3	14.27	300	4.50	1.85	60.2
85%	ST52-3	15.88	150	2.12	0.87	36.8
85%	ST52-3	15.88	200	2.60	1.06	43.9
85%	ST52-3	15.88	250	3.18	1.30	50.6
85%	ST52-3	15.88	300	3.80	1.55	59.3

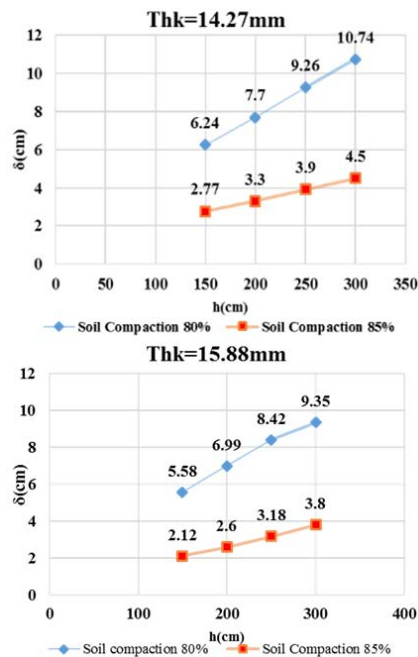

Fig. 10 Ovality of 14.27 mm and 15.88 mm thickness pipes buried under the soil with a compaction of 80% and 85%

Fig. 12 shows the stress exerted on the pipe as function of soil height. The results show an increase in the stress with increasing soil height on the pipe. For pipes of the same thickness, the stress exerted to the pipe significantly decreases with increasing the soil compaction from 80% to 85%.

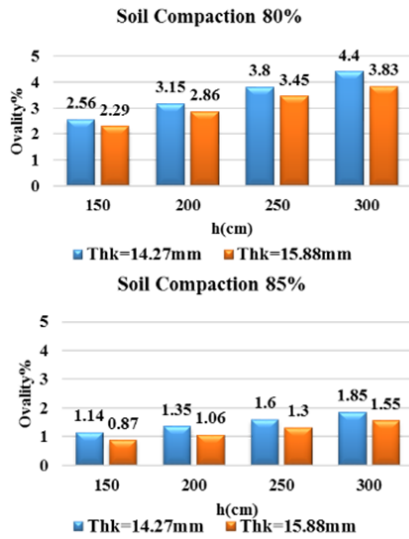

Fig. 11 Ovality percentage of 14.27 mm and 15.88 mm thickness pipes buried under the soil with a compaction of 80% and 85%

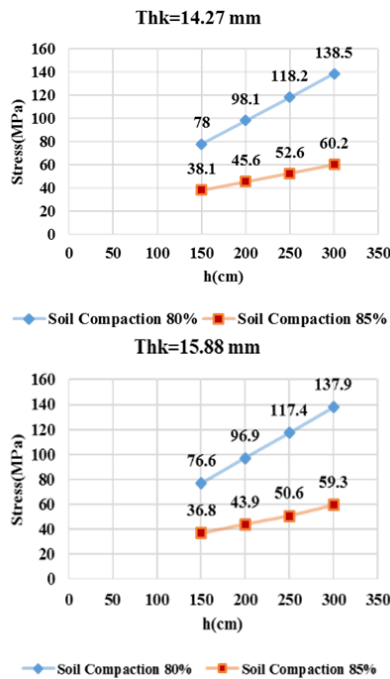

Fig. 12 Stress exerted on the pipe as function of soil height

III. EFFECT OF EXTERNAL LOADS ON PIPE OVALITY

This section discusses the effect of external loads on the ovality of buried pipes. To this end, the effect of a 25 ton mechanical excavator moving on the buried pipe is investigated. As a result of mechanical excavator movement, a pressure of 44 kPa is applied to the soil. Two modes were considered to investigate the effect of external load. The transverse movement of the mechanical excavator and then its movement along the pipeline are investigated. The soil height on the pipe equals 150 cm and the effect of external load is

studied as a function of soil compaction and pipe thickness. Fig. 13 shows the mechanical excavator dimensions. Loading conditions are shown in Figs. 14 and 16.

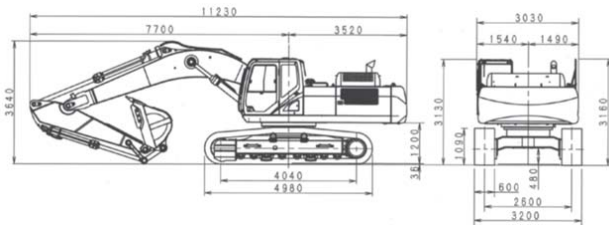

Fig. 13 Mechanical excavator dimensions

Below, the simulation results for 14.27 mm and 15.88 mm thick pipes buried under the soil with a compaction of 80% and 85% are discussed.

A. Transverse Movement of the Mechanical Excavator

The effect of transverse movement of the mechanical excavator on the buried pipeline is discussed in this section. Fig. 14 shows loading conditions, and the results are reported in Table X.

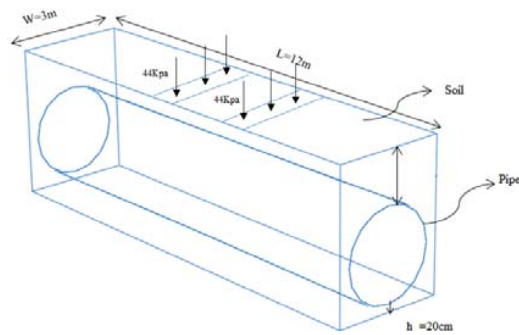
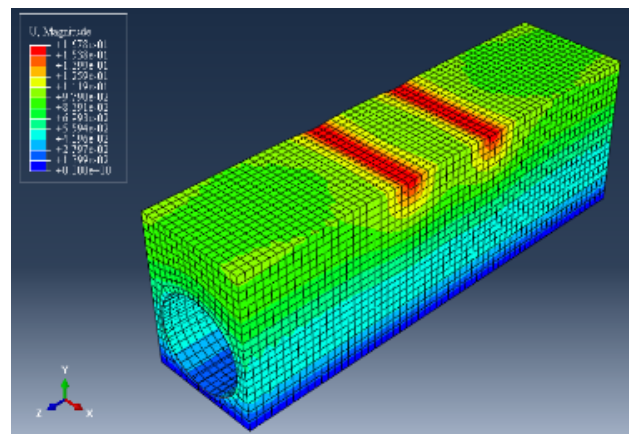
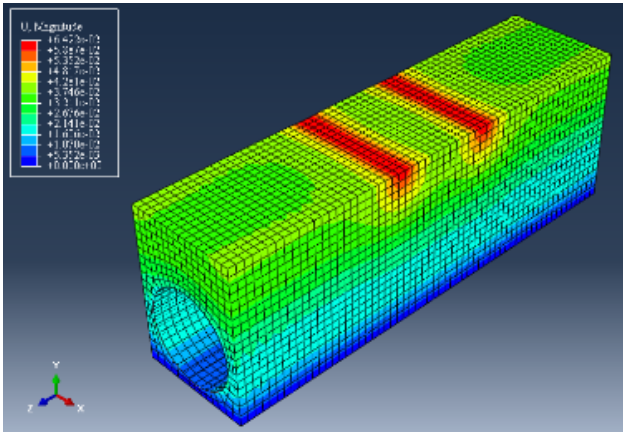

Fig. 14 Transverse movement and loading conditions



(a) t = 14.27 mm, soil compaction 80%



(b) $t = 14.27$ mm, soil compaction 85%

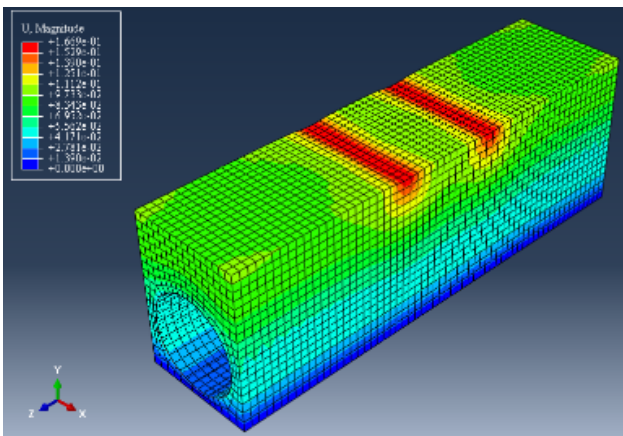

(c) $t = 15.88$ mm, soil compaction 80%

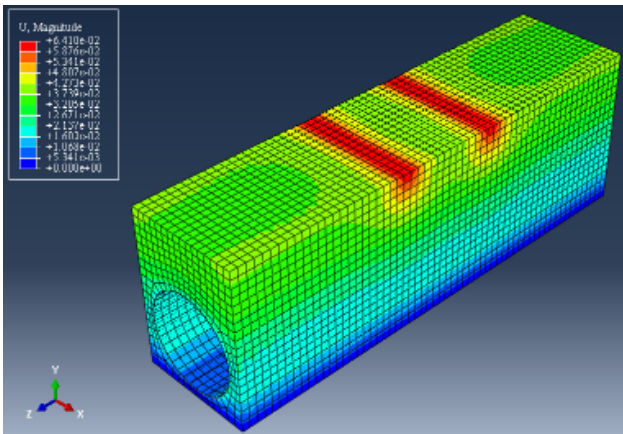

(d) $t = 15.88$ mm, soil compaction 85%

Fig. 15 Effect of external load on pipe ovality

B. Movement along The Pipeline

The effect of mechanical excavator movement along the pipeline on the buried pipeline is discussed in this section. Fig. 16 shows the loading conditions, and the results are reported in Table XI.

TABLE X
RESULTS OF OVALITY DUE EFFECT OF TRANSVERS MOVEMENT ON PIPE OVALITY

Soil compaction	Material	Thickness (mm)	H (cm)	P(Kpa)	δ (cm)	Ovality (%)
80%	ST52-3	14.27	150	44	8.4	3.48
85%	ST52-3	14.27	150	44	4.5	1.86
80%	ST52-3	15.88	150	44	7.8	3.24
85%	ST52-3	15.88	150	44	4.0	1.66

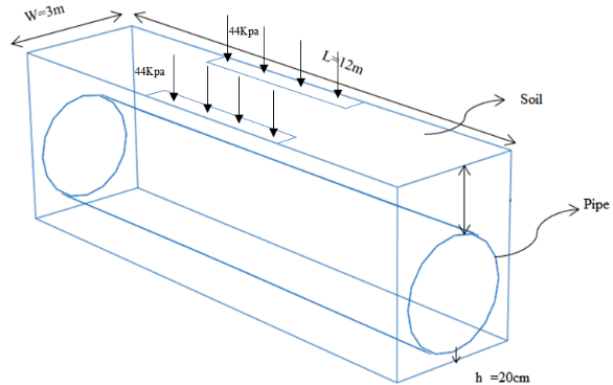
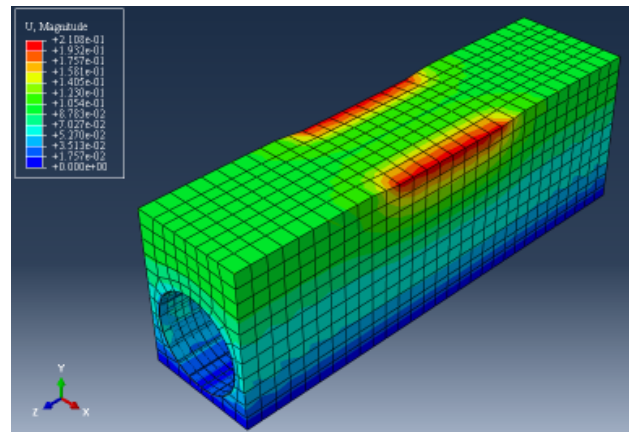

Fig. 16 Movement along the pipeline and loading conditions

Tables X and XI, respectively, show the results obtained from transverse and longitudinal movement of the mechanical excavator. As can be seen, the pipe ovality remains in the permissible limit by mechanical shovel movement and the ovality can be reduced by increasing soil compaction.

TABLE XI
RESULTS OF OVALITY DUE EFFECT OF LONGITUDE MOVEMENT ON PIPE OVALITY

Soil compaction	Material	Thickness (mm)	H (cm)	P(Kpa)	δ (cm)	Ovality (%)
80%	ST52-3	14.27	150	44	8.9	3.69
85%	ST52-3	14.27	150	44	4.7	1.95
80%	ST52-3	15.88	150	44	8.1	3.36
85%	ST52-3	15.88	150	44	4.2	1.74



(a) $t = 14.27$ mm, soil compaction 80%;

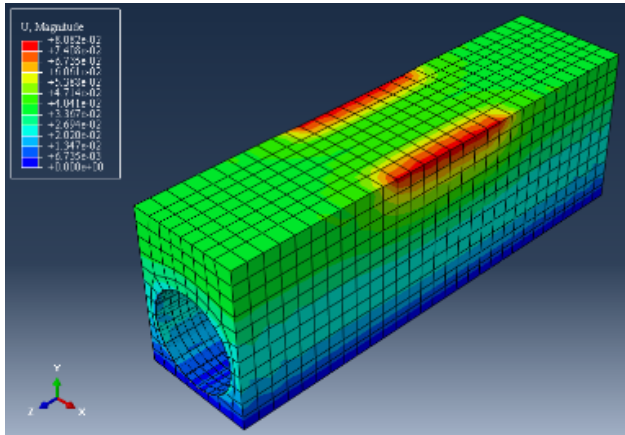

(b) $t = 14.27$ mm, soil compaction 85%;

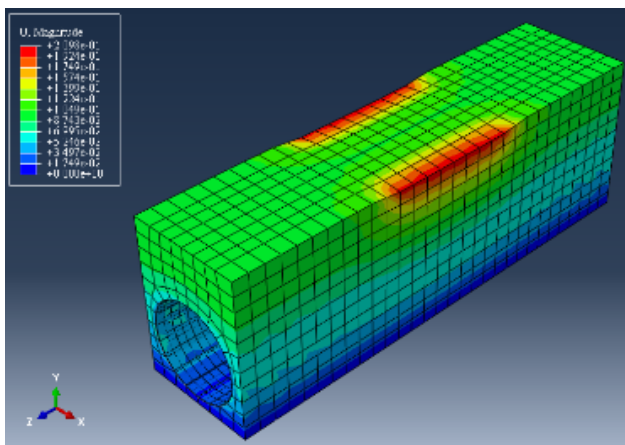

(c) $t = 15.88$ mm, soil compaction 80%;

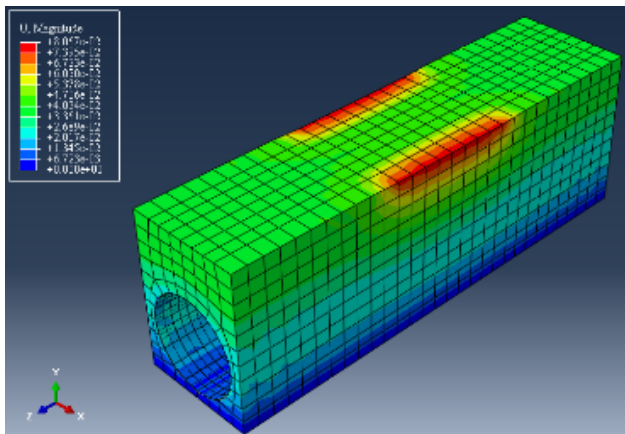

(d) $t = 15.88$ mm, soil compaction 85

Fig. 17 Effect of external load on pipe ovality

IV. ULTIMATE OVALITY

The ultimate ovality up to the plastic limit (permanent deformation) was calculated. To obtain the ultimate ovality, ST52-3 pipe with a thickness of 14.27mm and 15.88 mm

buried under the soil with a compaction of 85% was simulated. The simulation results are shown in Fig. 18.

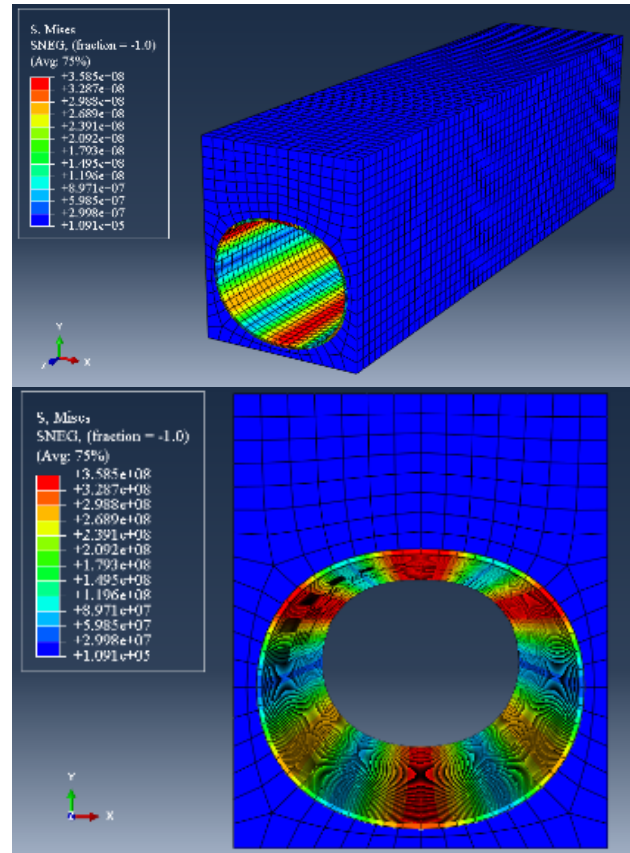

Fig. 18 Ultimate ovality

As seen, as a result of ovality of the ST52-3 pipes up to 26 cm equivalent to 10.6%, the stress reaches the plastic limit causing permanent deformation of the pipe. An increase in the pipe thickness causes an increase in the force required to reach the ovality limit.

V. CONCLUSION

The pipe ovality can be reduced by decreasing thickness in a soil with a constant compaction. Note that this requires more costs. An increase in the soil compaction leads to a decrease in the ovality and stress exerted to the pipe. Therefore, pipes of lower thickness can be used with increasing the soil compaction which is completely a cost-effective solution. It is noteworthy that the working pressure of the pipeline should be considered in the case of a decrease in the pipe thickness.

REFERENCES

- [1] Armin Boostani , Hossein Ansari, Seyed Hassan Golmaei, Mohammadreza Akbarzade, "Considering the effect of loads and surrounding texture on steel pipeline in potable municipal water networks with Ansys Finite Element Model", *Journal of Irrigation and Water Engineering*, vol.2, pp. 58-69, 2012.
- [2] Elachachi, S.M., D. Breyse and L. Houy. "Longitudinal variability of soils and structural response of sewer networks", *Computers and*

- Geotechnics*, vol. 31, 2004.
- [3] Hyde, T.H., R. Lou and A.A. Becker. "Analysis of stresses in pipes indented by long external indentation & subsequent stress variation due to pressure fluctuations", *International Journal of Pressure Vessels and Piping*, vol. 86, pp. 428-434, 2009.
- [4] Psyrras N., Sextos A., Kwon O.-S., Gerasimidis S. "On the safety factors of buried steel natural gas pipelines under spatially variable earthquake ground motion". *11th National Conference in Earthquake Engineering, Earthquake Engineering Research Institute*, Los Angeles, CA, 2018.
- [5] N. Psyrras, O. Kwonb, S. Gerasimidisc, A. Sextosd. "Can a buried gas pipeline experience local buckling during earthquake ground shaking?", *Soil Dynamics and Earthquake Engineering*, vol. 116, pp. 511-529, 2019.
- [6] Grigorios Tsinidis, Luigi Di Sarno, Anastasios Sextos, Nikolaos Psyrras and Peter Furtner. "On the numerical simulation of the response of gas pipelines under compression". *9th International Conference on Advances in Steel Structures (ICASS)*, Hong Kong, China, 5-7 December 2018.
- [7] Bulent Akbas, Eren Uçkan, "Performance-based design of buried steel pipes at fault crossing", *Pressure and Vessels & Piping Conference*, , Boston, Massachusetts, USA, July 19-23 2015
- [8] Kawaljitsingh Randhawa, "Ovality in pipes", *International Journal of Latest Technology in Engineering, Management & Applied Science*, vol. 6, pp. 44-46, July 2017.