

Structural Design Strategy of Double-Eccentric Butterfly Valve using Topology Optimization Techniques

Jun-Oh Kim, Seol-Min Yang, Seok-Heum Baek, Sangmo Kang

Abstract—In this paper, the shape design process is briefly discussed emphasizing the use of topology optimization in the conceptual design stage. The basic idea is to view feasible domains for sensitivity region concepts. In this method, the main process consists of two steps: as the design moves further inside the feasible domain using Taguchi method, and thus becoming more successful topology optimization, the sensitivity region becomes larger. In designing a double-eccentric butterfly valve, related to hydrodynamic performance and disc structure, are discussed where the use of topology optimization has proven to dramatically improve an existing design and significantly decrease the development time of a shape design. Computational Fluid Dynamics (CFD) analysis results demonstrate the validity of this approach.

Keywords—Double-eccentric butterfly valve, CFD, Topology optimization

I. INTRODUCTION

BUTTERFLY valves are widely used as control valves for industrial plants such as gas plant, generating plant and LNG ships. Butterfly valves are generally favored because they are lower in cost to other valve designs as well as being lighter in weight, meaning less support is required. Butterfly valve is a quarter-turn rotational motion valve that is used to stop, regulate, and start flow. Butterfly valve is two types; concentric butterfly valve is used for opening and closing with a simple valve shape and light weight. High torque is experienced at open or close position. Eccentric butterfly valve is used for flow control and has the advantages of low fluid pressure and torque with heavy disc weight and complicated shape. Commonly, the disc shape of butterfly valve is important for the flow characteristics such as pressure drop and hydrodynamic torque. Pressure drop is an important factor in the flow coefficient which is widely used for the determination of valve specifications.

$$C_v = Q \sqrt{\frac{S_g}{\Delta P}} \quad (1)$$

where Q is the flow rate (Gal/min), S_g is the fluid specific weight and ΔP is the pressure drop (psi). Eq. (1) means that when the pressure drop between measuring intervals is 1 psi, the flow rate through them is 1 gallon.

Jun-Oh Kim and Seol-Min Yang are with the School of Mechanical Engineering, Dong-A University, Busan, Korea (e-mail: feel3429@hotmail.com).

Seok-Heum Baek is with the Department of Mechanical Engineering, Dong-A University, Busan, Korea (e-mail: baekseokh@gmail.com).

*Corresponding author, Sang-Mo Kang is with the Department of Mechanical Engineering, Dong-A University, Busan, Korea (phone: +82-51-200-6982; fax: +82-51-200-6979; e-mail: kangsm@dau.ac.kr).

The flow characteristic of valve can be predicted by Computational Fluid Dynamics (CFD) analysis, the advantage of saving the money and time.

Hence, optimization for the performance and structural stability of butterfly valve is conducted. In this study, we conduct topology optimization to reduce weight, pressure drop and torque in the initial model.

II. MATHEMATIC MODEL AND NUMERICAL ANALYSIS

A. Explanation of Valve Disc Model

Fig. 1 shows the double-eccentric butterfly valve made by H-company. It consists of valve body, shaft, disc and bush for blocking leakage. Fig. 2 depicts the flow domain and the computational grid system for the CFD analysis. Inlet and outlet diameters are expanded to 10D and 20D where to increase the convergence accuracy of the CFD analysis and also for the fully developed flow of fluid. In this paper, we create hexahedron and tetrahedron meshes using ANSYS CFX-MESH v12.1. The number of elements is 2.3×10^6 at valve region and 1.6×10^6 at pipe region.

TABLE I
MAIN SPECIFICATIONS OF THE DOUBLE-ECCENTRIC BUTTERFLY VALVE

Type	Face to face : ISO 5752
Operation conditions	
Valve size	100A
Design pressure (kg/cm ²)	10
Operating temperature (°C)	20
Operating fluid	Water
Material properties	
Body and disc	CF8M steel
Shaft and bush	SUS 316L

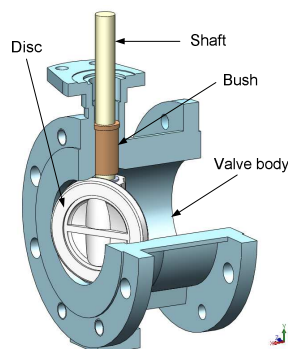

Fig. 1 Overall structure of a double-eccentric butterfly valve

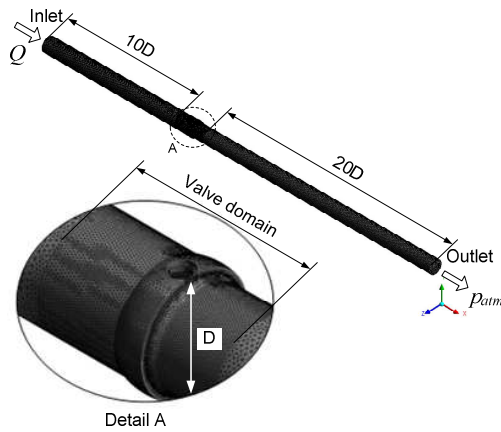

Fig. 2 Flow domain and the computational grid system

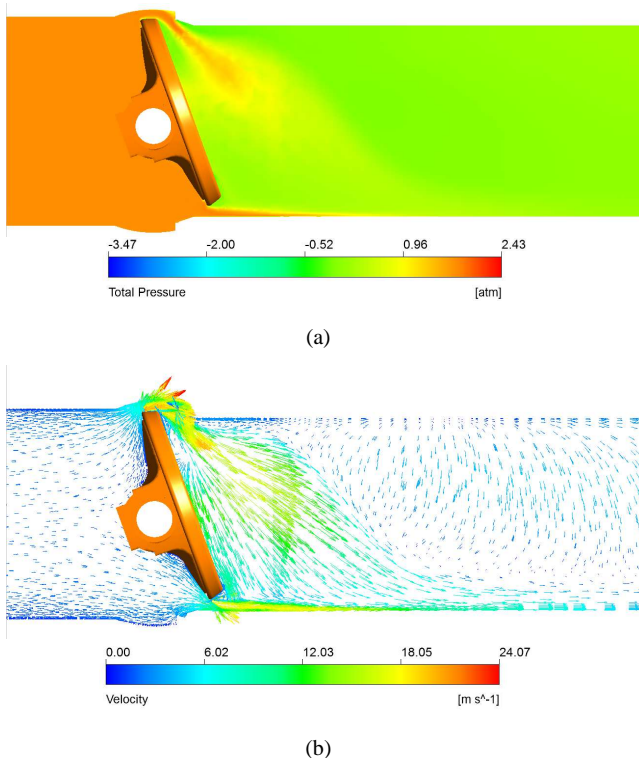

Fig. 3 CFD results of valve disc at 20° opening, (a) pressure, (b) velocity magnitude

B. Numerical method

The governing equations for analyzing turbulent flow occurring in valve consist of continuity and Navier-Stokes equations. We use Shear Stress Transportation (SST) turbulent model [10,12] in ANSYS CFX. It uses $k-\omega$ model near wall and $k-\epsilon$ model at free shear flow. We assume that the working fluid for the analysis is water at 20°C and the boundary conditions are flow rate at inlet, atmospheric pressure at outlet and no-slip conditions at wall. We conduct CFD analysis about 20° where we expect that pressure drop and hydrodynamic torque have the most highest value.

Pressure drop is calculated between 2D and 6D away from the valve disc by Korean Industrial Standard and the hydrodynamic torque is calculated at disc face from the valve axis. Even though, Frictional coefficient for turbulent flow depends on Reynolds number and relative roughness we assume smooth pipe for the CFD analysis. Generally, pressure drop occurs because of fluid flow through narrow fluid region created by disc opening angle. Pressure variation is that Dynamic pressure in valve inlet changes to static pressure in valve disc region and then change again to dynamic pressure after passing disc. Fig. 3 shows CFD result of initial shape. Vortex occurs in the wake of valve due to the disc shape. Therefore, reducing vortex, pressure drop and hydrodynamic are required by changing the disc shape.

We suggested two methods; Taguchi experimental design and Topology optimization. The Taguchi method is one of the most efficient DOE methods. The signal-to-noise (S/N) ratio, a measure that simultaneously considers the average and variations of responses, is based on the analysis of variance (ANOVA) technique.

Taguchi's approach is a method for improving the quality of a product through minimizing the effect of variation without eliminating the causes. Reducing the variation may be the same as increasing the S/N ratio. The S/N ratio can be defined as nominal-the-best, smaller-the-better or larger-the better according to the characteristics of the problem. Since pressure drop, hydrodynamic torque and volume in this paper hold the smaller-the-better characteristics, the S/N ratio is defined as

$$S/N_{\text{smaller}} = -10 \log \left(\frac{1}{n} \sum_{i=1}^n y_i^2 \right) \quad (2)$$

where n is the number of repetition and y_i is the value of the i th data point [13]. Fig. 4 shows that optimization procedure suggested in this paper for disc of a butterfly valve. The first step is to define a design space for the initial shape and then to get design variables and objective. We conducted CFD analysis using orthogonal array.

Fig. 5 shows selected design variable in butterfly valve; x_1 double-eccentric, x_2 angle between disc and shaft housing, x_3 disc thickness, x_4 shaft diameter, x_5 between shaft housing gap. Shape of disc and mounting structure affect to pressure drop and hydrodynamic torque. In Table II, the levels of each design variable are assumed to be equally space. In this paper, initial disc value is level 3. x_1, x_3, x_5 are $\pm 15\%$ between maximum and minimum and x_2, x_4 are $\pm 10\%$, $\pm 13\%$ for each.

Table III shows design matrix of L_{25} orthogonal arrays and CFD result. Sensitivity analysis of design variable is conducted using this result. Fig. 6 shows the main effect of the S/N ratio on the five design variables. Main effect of SN ratio helps to get important information about design direction of design variable. If x_3 becomes level 1, fluid characteristic and volume will be improved. It is hard for changing disc thickness only to improve valve performance from this result. Therefore, layout for disc thickness is reviewed and need to determinate shape for improving degree of freedom in design.

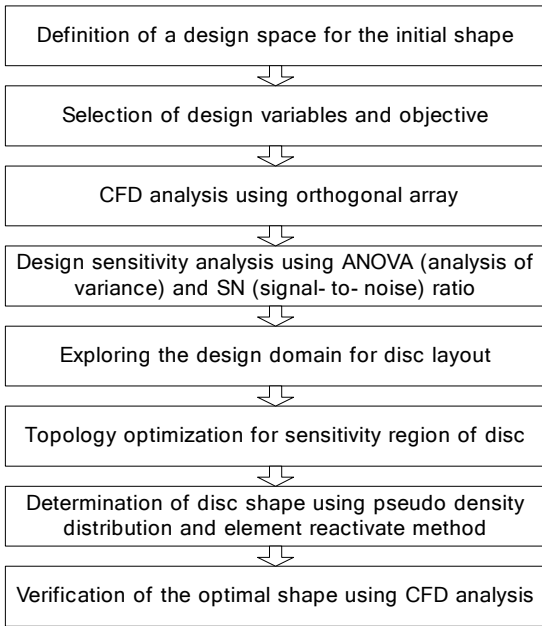

Fig. 4 Flowchart of the valve disc optimization procedure

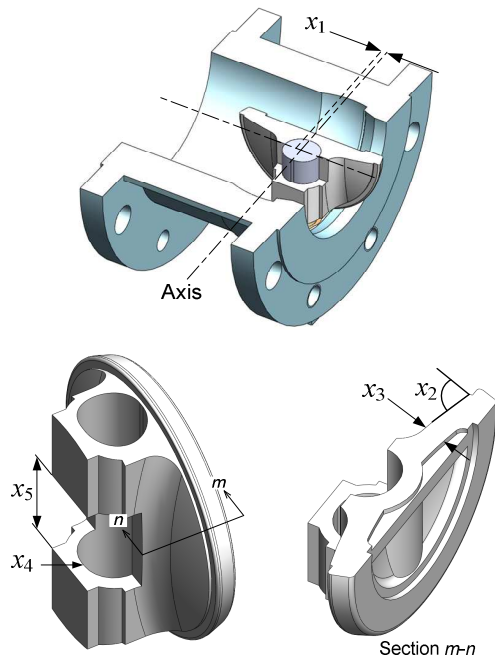

Fig. 5 Design variables of a double-eccentric butterfly valve

III. TOPOLOGY OPTIMIZATION

The goal of topology optimization is to redistribute materials to provide maximum stiffness for various mass constraint conditions. The goal of topological optimization is to find the best use of material for a body such that an objective criteria takes out a maximum or minimum value subject to given constraints [10]. In the case of maximum static stiffness design subject to a volume constraint, which sometimes is referred to as the standard formulation of layout problem, one seeks to

TABLE II
DESIGN VARIABLES AND THEIR LEVELS

Design variable	Unit	Level 1	Level 2	Level 3	Level 4	Level 5
x_1	mm	0	1.25	2.5	3.75	5
x_2	Deg.	80	76.5	73	69.5	66
x_3	mm	5.5	7	8.5	10	11.5
x_4	mm	14.5	15.5	16.5	17.5	18.5
x_5	mm	51	42.5	34	25.5	17

TABLE III
DOE LAYOUT AND CFD RESULT FOR L_{25} ORTHOGONAL ARRAYS

Exp.	x_1	x_2	x_3	x_4	x_5	ΔP [kPa]	Torque [N-m]	Volume [mm ³]
1	1	1	1	1	1	153	44.5	67702
2	2	2	2	2	2	158	45.8	81557
3	3	3	3	3	3	172	47.5	95679
4	4	4	4	4	4	213	54.0	110390
5	5	5	5	5	5	225	46.4	126640
6	1	2	3	4	5	190	51.1	100710
7	2	3	4	5	1	212	52.6	109410
8	3	4	5	1	2	240	50.7	114330
9	4	5	1	2	3	151	44.0	71998
10	5	1	2	3	4	153	44.8	86254
11	1	3	5	2	4	303	54.5	118020
12	2	4	1	3	5	142	39.7	76754
13	3	5	2	4	1	169	49.1	83506
14	4	1	3	5	2	183	51.2	96392
15	5	2	4	1	3	188	51.0	104780
16	1	4	2	5	3	174	46.9	89556
17	2	5	3	1	4	181	49.3	97552
18	3	1	4	2	5	189	51.0	109500
19	4	2	5	3	1	274	56.6	111720
20	5	3	1	4	2	147	42.9	75521
21	1	5	4	3	2	231	53.8	105710
22	2	1	5	4	3	298	56.4	116910
23	3	2	1	5	4	161	46.7	78530
24	4	3	2	1	5	162	47.1	87080
25	5	4	3	2	1	173	48.6	91113

minimize the energy of the structural static compliance for a given load case subject to a given volume reduction. Minimizing the compliance is equivalent to maximizing the global structural static stiffness. In this case, the optimization problem is formulated as shown in Eq. (3).

$$\begin{aligned}
 &\text{Minimize } V = \frac{1}{n} \sum_i^n [\eta_i v_i] \\
 &\text{subject to } 0 \leq \eta_i \leq 1 \quad (i=1,2,\dots,n) \\
 &\quad \quad \quad \underline{U}_c^j \leq U_c^j \leq \overline{U}_c^j \quad (j=1,2,\dots,m) \\
 &\quad \quad \quad V \leq V_0 \leq V^*
 \end{aligned} \tag{3}$$

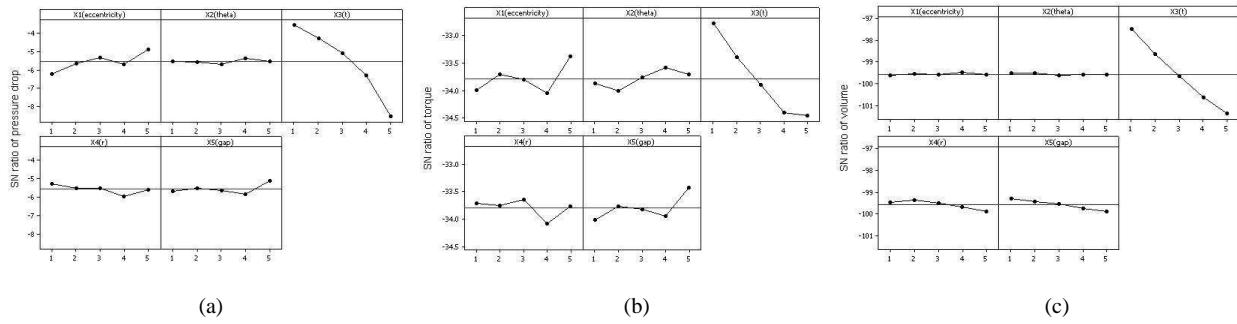

Fig. 6 Main effect plot of design variable; (a) pressure drop, (b) hydrodynamic torque, and (c) volume

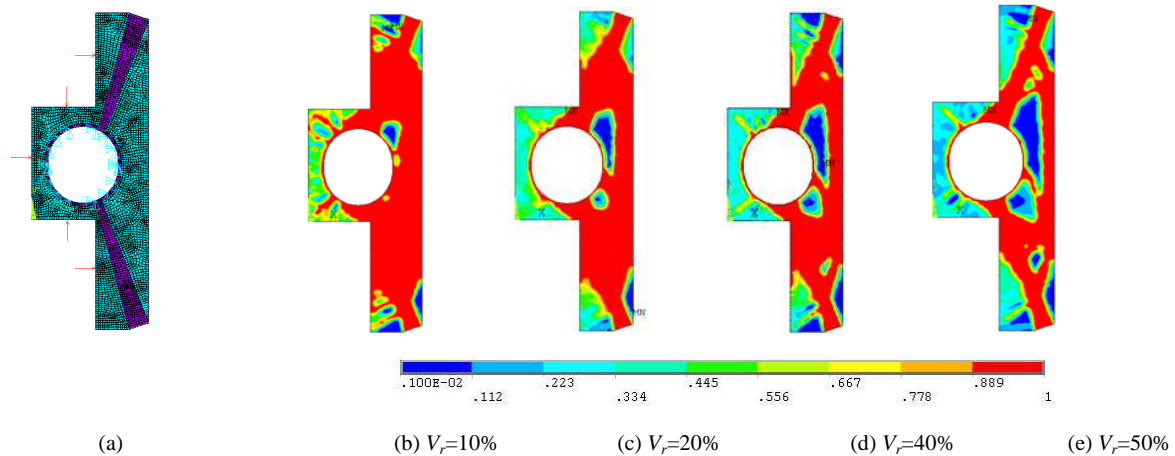

Fig. 7 (a) Design domain and boundary conditions for the disc, (b)-(e) density distributions for volume reduction (V_r) at topology optimization result. The material constants are $E=196$ GPa, $\nu=0.29$ and the pressure is $p=1$ MPa

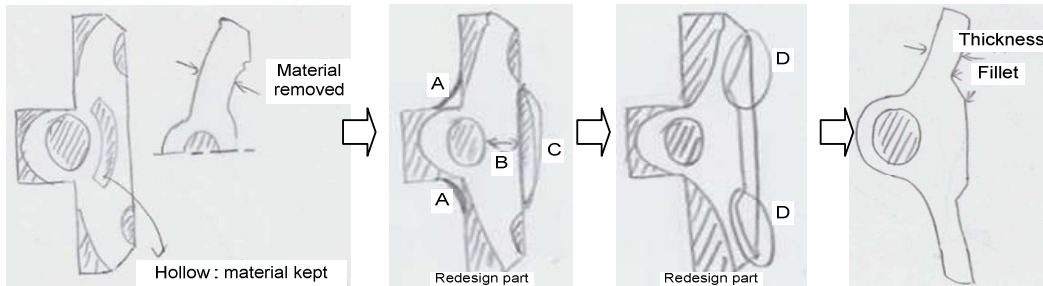

Fig. 8 Representative drawings for sketch tasks using topology optimization

where η_i is the pseudo density and v_i the volume of element i .

The pseudo density for each element varies from 0 to 1; where $\eta_i \approx 0$ represents material to be removed; and $\eta_i \approx 1$ represents material that should be kept. Total volume V of the structure is pseudo density in element of unit volume. Target volume is initial volume (V_0) minus reduced amount of volume (V^*). Design variable is the pseudo density of the element which varies from 0 (material is removed) to 1 (material is preserved). Determining the layout of the structure is applied in concept design for disc of butterfly valve from Eq. (3). If the present model is excessively designed, it is used for reducing the volume without making the performance worse.

We modify complicated section in the initial model and then make the primitive model to determine disc layout.

Fig. 7(a) shows the design region and boundary condition in topology optimization of disc using ANSYS APDL[16]. We aim to reduce or preserve part of disc. Elastic modulus and Poisson's ratio is applied in mechanical properties of CF8M and the design pressure of disc is 1 MPa. Fig. 7(b)-(e) shows the density distribution for volume decrement 10% to 50% in disc design region. The region where the density distribution is zero can be removed and the region where the density distribution is one must be maintained.

Fig. 8 shows the process of disc sketch using density of topology optimization. We draw profile to reduce low density section and disc depth. Surface is added for decreasing stress Concentration of edge of back of the disc.

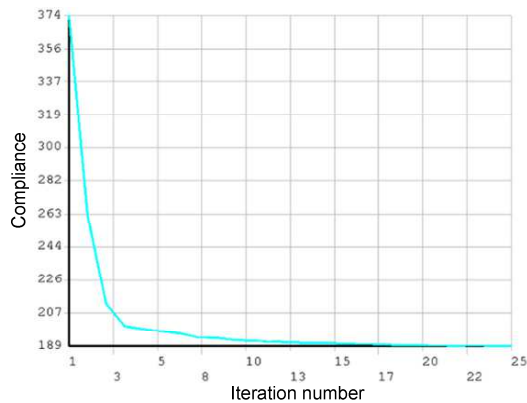

Fig. 9 Convergence history of the compliance objective function

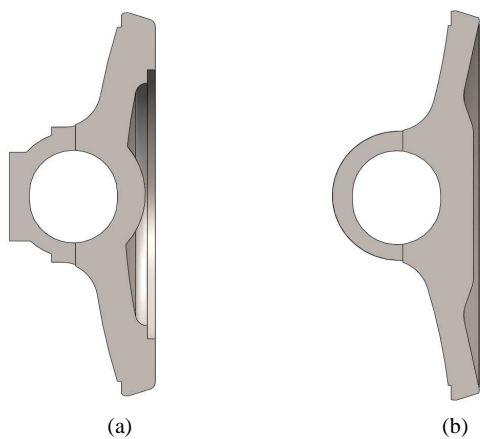

Fig. 10 Comparison of disc shape between (a) the initial design and (b) the modified design

Processing problem is expected we remove hollowness of the disc center. Fig. 9 shows convergence of topology optimization for the element deactivation process. Optimal criteria method is used in optimization algorithm [16-17]. The compliance gradient is converged in a regular interval during the redistribution of a material in a design region.

In this paper, we use a convergence limit of 2.5×10^{-4} and it is converged after 25 times. The optimized disc shape is compared with the initial shape in Fig. 10. Disc depth is thinner and the curvature at front of disc is changed to simple design. In the initial model of Fig. 11, the vortex flow occurs through the disc. This interrupts the fluid flow and increases the pressure drop. Table IV shows the comparison of the fluid characteristics for the initial and optimized model based on CFD analysis. By suitably selecting design variables for the modified design and performing an optimization will be our future work.

IV. CONCLUSION

This paper presents topology optimization of a double eccentric butterfly valve disc. We determine the shape of the disc using topology optimization. We compared the initial design with the optimal design. It is found that the pressure drop decreases by 8% and torque reduces by 5% in the modified

design compared to the initial design. Also, the disc volume is reduced by 10% by using a modified design.

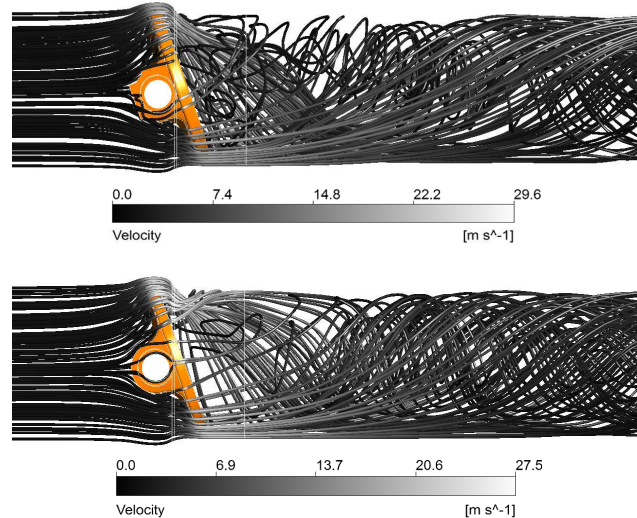

Fig. 11 CFD result of velocity magnitude for valve disc at 20 opening; (a) initial design (b) optimal design

TABLE IV
INITIAL DESIGN VS OPTIMAL DESIGN

Step	ΔP [kPa]	Torque [N-m]	Volume [mm ³]
Initial design	172	47.5	95679
Optimal design	159	45.2	85507

The main result can be summarized as follows.

- (1) Reducing pressure drop, hydrodynamic torque and volume are affected by disc thickness more than other variables for double-eccentric butterfly valve from ANOVA result by design of experiment and sensitivity analysis.
- (2) Disc design needs fast and accurate shape design process for efficient design satisfied in valve performance.

ACKNOWLEDGMENT

This work was supported by Technical Center for High Performance Valves Form the Regional Innovation Center (RIC) Program of the Ministry of Knowledge Economy (MKE), Korea.

REFERENCES

- [1] F. Danbon, and C. Sollic, "Aerodynamic Torque of a Butterfly Valve-Influence of an Elbow on the Time-Mean and Instantaneous Aerodynamic Torque," ASME J. Fluids Eng., Vol. 122, No. 2, 2000, pp.337-344
- [2] Z. Leutwyler, and C. Dalton, "A Computational Study of Torque and Forces Due to Compressible Flow on a Butterfly Valve Disk in Mid-stroke Position," ASME J. Fluids Eng., Vol. 128, No. 5, 2006, pp.1074-1082.
- [3] C. C. Tsai, C. Y. Chang, and C. H. Tseng, "Optimal Design of Metal Seated Ball Valve Mechanism," Struct. Multidisc. Optim., Vol. 26, No. 3-4, 2004, pp.249-255.

- [4] P. Duda, and R. Dwornicka, "Optimization of Heating and Cooling Operations of Steam Gate Valve," *Struct. Multidisc. Optim.*, Vol. 40, No. 1-6, 2010, pp.529-535.
- [5] J. Y. Park, and M. K. Chung, "Study on Hydrodynamic Torque of a Butterfly Valve," *ASME J. Fluids Eng.*, Vol. 128, No. 1, 2006, pp.190-195.
- [6] X. G. Song, L. Wang, S. H. Baek, and Y. C. Park, "Multidisciplinary Optimization of a Butterfly Valve," *ISA Trans.*, Vol. 48, No. 3, 2009, pp.370-377.
- [7] M. P. Bendsoe, and N. Kikuchi, "Generating Optimal Topologies in Structural Design Using a Homogenization Method," *Comput. Meth. Appl. Mech. Eng.*, Vol. 71, No. 2, 1988, pp.197-224.
- [8] M. I. Frecher, G. K. Ananthasuresh, S. Nishiwaki, N. Kikuchi, and S. Kota, "Topological Synthesis of Compliant Mechanisms Using Multi-Criteria Optimization," *ASME J. Mech. Des.*, Vol. 119, No. 2, 1997, pp.238-245.
- [9] S. H. Baek, K. Y. Lee, S. S. Cho, D. Y. Jang, and W. S. Joo, "Optimal Design of Electric Vehicle Cross Beam for Adaptive Design of Homogenized Structure," *Trans. of the KSAE*, Vol. 12, No. 5, 2004, pp.85-93.
- [10] ANSYS CFX, User Manual Release 12.1, ANSYS Inc., 2011.
- [11] T. J. Barth, and D. C. Jespersen, "The Design and Application of Upwind Schemes on Unstructured Meshes," *AIAA J.*, Vol. 89, No. 89-0366, 1989, pp.1-12.
- [12] F. R. Menter, "Two-equation Eddy-viscosity Turbulence Models for Engineering Applications," *AIAA J.*, Vol. 32, No. 8, 1994, pp.1598-1605.
- [13] M. S. Phadke, *Quality Engineering Using Robust Design*, Prentice Hall, Englewood Cliffs, NJ, 1989.
- [14] S. H. Baek, S. H. Hong, S. S. Cho, D. Y. Jang, and W. S. Joo, "Optimization of Process Parameters for Recycling of Mill Scale Using Taguchi Experimental Design," *J. Mech. Sci. Technol.*, Vol.24, No.10, 2010, pp.2127-2134.
- [15] A. R. Diaz, and N. Kikuchi, "Solutions to Shape and Topology Eigenvalue Optimization Problems using a Homogenization Method," *Int. J. Numer. Methods Eng.*, Vol. 35, 1992, pp.1487-1502.
- [16] ANSYS Theory Reference Release 11.0, SAS IP, Inc., 2007.
- [17] H. Behrooz, and H. Ernest, *Homogenization and Structural Topology Optimization: Theory, Practice and Software*, Springer-Verlag, 1999.

Jun-Oh Kim and Seol-Min Yang received a B.S. degree in Mechanical Engineering from the Dong-A University in 2011 They are currently a M.S. student at the School of Mechanical Engineering at Dong-A University in Busan, South Korea. Student Kim, Yang work on CFD.

Seok-Heum Baek received his B.S. in Mechanical Engineering from Dong-A University, South Korea, in 2001. He then went on to receive his M.S. and Ph.D degrees from Dong-A University, South Korea, in 2003 and 2010, respectively. Dr. Baek is currently a BK21 Post-Doctoral Fellow at the School of Mechanical Engineering at Dong-A University in Busan, South Korea. His research interests cover the area of metamodeling, multidisciplinary modeling and optimization methods, and fatigue fracture analysis.

Sangmo Kang received B.S. and M.S degrees in Mechanical Engineering from Seoul National University in 1985 and 1987. He then went on to receive his Ph.D degree from University of Michigan in 1996. Dr. Kang is currently a Professor at the Mechanical Engineering at Dong-A University in Busan, South Korea. His research interests are in the area of CFD and Micro flow.