

Steady State Simulation and Experimental Study of an Ethane Recovery Unit in an Iranian Natural Gas Refinery

Arash Esmaeili, Omid Ghabouli

Abstract—The production and consumption of natural gas is on the rise throughout the world as a result of its wide availability, ease of transportation, use and clean-burning characteristics. The chief use of ethane is in the chemical industry in the production of Ethene (ethylene) by steam cracking. In this simulation, obtained ethane recovery percent based on Gas sub-cooled process (GSP) is 99.9 by mole that is included 32.1% by using de-methanizer column and 67.8% by de-ethanizer tower. The outstanding feature of this process is the novel split-vapor concept that employs to generate reflux for de-methanizer column. Remain amount of ethane in export gas cause rise in gross heating value up to 36.66 MJ/Nm³ in order to use in industrial and household consumptions.

Keywords—Ethane recovery, Hydrocarbon dew point, Simulation, Water dew point

I. INTRODUCTION

AFTER methane, ethane is the second-largest component of natural gas. Natural gas from different gas fields varies in ethane content from less than 1% to over 6% by volume. Prior to the 1960s, ethane and larger molecules were typically not separated from the methane component of natural gas, but simply burnt along with the methane as a fuel. Today, ethane is an important petrochemical feedstock, and it is separated from the other components of natural gas in most well-developed gas fields. Ethane can also be separated from petroleum gas, a mixture of gaseous hydrocarbons that arises as a byproduct of petroleum refining. Ethane is most efficiently separated from methane by liquefying it at cryogenic temperatures.

For Ethane recovery, the key components in separation process are methane and ethane but for propane recovery, they are ethane and propane, thus primary need is de-methanizer and de-ethanizer respectively. Relative volatility (α_{ij}) of the ethane recovery is over twice that of the propane recovery system which leads de-methanizer should be smaller than de-ethanizer in terms of equilibrium stages [1].

There are various refrigeration strategies in an Ethane recovery unit, the most economical process presently in wide use employs turbo-expansion, and can recover over 90% of the ethane in natural gas by using de-methanizer and de-ethanizer columns. The processing costs for gas processor can generally be divided into two parts: liquid recovery and contaminant removal. In this process, chilled gas expands through a turbine so that at low temperatures, gaseous methane can be separated from the liquefied ethane and heavier hydrocarbons (C₂₊) by distillation. Further distillation then separates ethane from the propane and heavier hydrocarbons (C₃₊).

Turbo-expander plants designed for high ethane recovery will also recover a significant quantity of the carbon dioxide contained in the feed gas [2]. With typical natural gas liquid product specification, this usually means treating either the feed gas or the NGL product to remove at least a portion of carbon dioxide. In a liquid recovery section, there are both operating cost and operating flexibility issues that directly affect processing cost.

Recent paper will study an Iranian Ethane recovery unit as *Gas Sub-cooled Process* (GSP) [3] in one of gas refineries in South Pars Gas field which receives 2000 MMSCFD sour gas (each train 500MMSCFD) as feed so that export (sales) gas specification e.g. composition, hydrocarbon dew point, higher heating value, Wobbe index, Hydrate formation condition and also Ethane specification e.g. composition, CO₂ content, CO₂ freeze temperature and total sulfur will be investigated and compared with specified targets after simulation by *Aspen Hysys* software (ver.2006) based on *Peng-Robinson* equation of state.

II. PROCESS DESCRIPTION

In this process, dry sweet feed (27.7°C, 60.5 barg) after sweetening by amine and dehydration by molecular sieves with standard gas flow 478.5 MMSCFD is primarily cooled by cold box up to -35°C while a portion of feed gas is

Arash Esmaeili is with Islamic Azad University, Tehran-South Branch, Chemical Engineering Department, Tehran, Iran (Phone: 98-912-5130090, e-mail: arash.esmaeili2010@gmail.com)

Omid Ghabouli is with Catalysis Research and Technology Center, Research Institute of Oil Industry, Tehran, Iran (Phone: 98-936-2055883, e-mail: omid.ghabouli@yahoo.com)

condensed which is included 4% by mole and separated by expander suction drum and is entered to tower on 21st tray, remain gas from top of drum is divided to two parts so that 71% mole flows to expander and rest of it after cooling by cold box and pressure drop by control valve decreases to -95°C that is introduced to de-methanizer (31 stages) column on top as reflux stream. To recover ethane and heavier hydrocarbon, energy must be consumed that is supplied by either expansion or refrigeration or a combination of both. Expansion by using an expander causes increased investment cost while cooling by refrigeration raises both investment and operation costs while in order to recover more ethane, the amount of external power supplied to the gas must increase. Main stream is expanded within expander to -67°C and 29.1 barg and is entered to tower as major feed on 23rd tray where column diameter changes; these two streams are as hot streams inside the cold box while cold box has five cold streams that are followed as:

1. Top stream of de-methanizer column as Export gas from -86°C to 22°C .
2. First side stream of de-methanizer column from 8th tray to 7th that temperature changes from 12.5°C to 16.2°C .
3. Second side stream of de-methanizer column from 17th tray to 16th so that temperature rises from -43°C to -14°C .
4. Two propane streams from refrigeration unit as cooling cycle.

In refrigeration cycle, liquid form accumulator flows through an expansion valve where its pressure is reduced, its temperature is lowered and the stream flows to the related heat exchangers. In the exchangers, liquid refrigerant removes heat from gas. As the refrigerant removes heat, it boils. The vapors flow out the top of the chiller back to the compressor and the cycle repeats.

In fact, any fluid can act as a refrigerant but a suitable one should have the following characteristics:

1. It should boil in the chiller at a pressure above atmosphere. This keeps the compressor from "pulling a vacuum" on the chiller.
2. It should condense at a reasonable pressure at ambient temperature.
3. It should be able to pick up a large amount of heat from the fluid stream per volume unit of circulation.
4. It should be non-toxic and non-corrosive.
5. It should be readily available and inexpensive.

The circulation rate of the refrigeration is determined by two factors:

1. The total amount of heat to be removed from the gas
2. The amount of heat that mass unit of refrigeration can pick up in the chiller.

Fig.1 shows phase envelope of feed stream and Fig. 2 represents phase envelope of top of expander suction drum

after separation of some liquid that express phase variations based on composition changes. Comparison of these curves indicates two phase area will be smaller and temperature, pressure zones are decreased after separation of liquid.

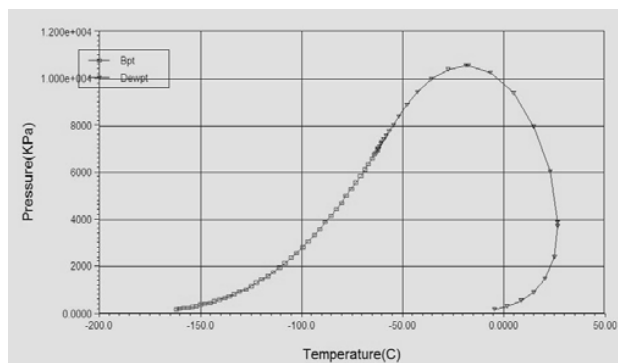

Fig. 1 Phase envelope of inlet feed to ethane recovery unit (feed in the right side of dew point curve)

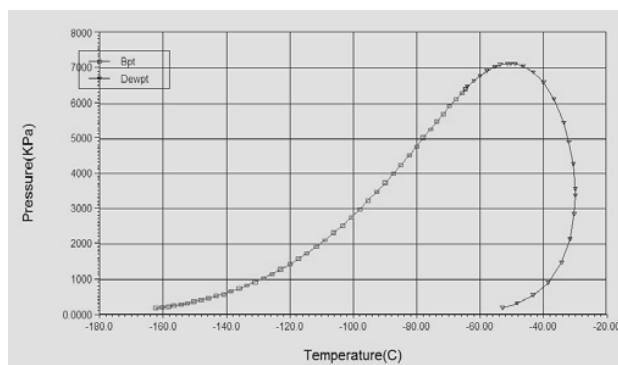

Fig. 2 Phase envelope of expander suction drum top stream (-35.5°C , 58.5 barg)

As is illustrated in Fig.3, outlet propane from accumulator of refrigeration unit after being cooled by expansion valves and performing chilling in cold box and de-ethanizer condenser is introduced to first and second propane suction drum in order to compress to the pressure (22.6barg) that is condensed in ambient temperature. Export gas which is free of Mercaptan with trace amount of H_2S after heat transfer with cold box and a gas/gas exchanger is compressed by a re-compressor to 32.19 barg which moves using produced work of expander by isentropic process for energy recovery (3228 KW with adiabatic efficiency 83%). Produced export gas with standard gas flow 443 MMSCFD possesses 32.1% by mole total ethane that is exported in 91.8 barg, rest of ethane is separated by de-ethanizer which has 67.8% mole total inlet ethane to this unit (95% mole of ethane product) and is exited from its top as petrochemical feedstock and 0.1% is accompanied with NGL in bottom side. Natural gas liquid (40.3°C , 32.2 barg) is pumped to de-ethanizer column (44stages) and distilled in order for separation of ethane from C_3+ while require temperature to condense heavier components than Ethane in operating pressure is almost 7.7°C that needs 3640 KW energy which is provided by using Propane in chiller as condenser, then ethane is transferred to treatment

unit after passing from Ethane heater (40°C, 28.5 barg) and is treated to remove CO₂ in order to rise heating value by DEA solution and being dried with molecular sieve before export to petrochemical plants. CO₂ is a particularly troublesome contaminant often found in natural gas, including many of the newly discovered oil and natural gas reservoirs.

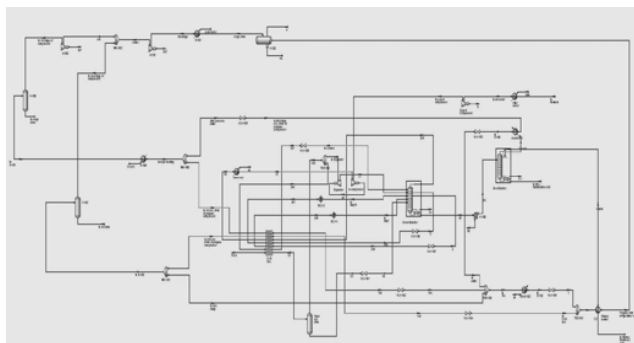

Fig. 3 Simulated process of an Ethane recovery unit with refrigeration package

III. RESULTS AND DISCUSSION

Generally, four major categories of ethane recovery processes were found: Conventional, classic, residue recycle and reflux enhancement. The majority of ethane recovery processes utilize a single tower of de-methanizer and provide reflux to this column by either direct flow from the expander (conventional), condensing a part of the inlet gas (classic) such as this unit, condensing recycled residue gas (residue recycle) and enhancing or purifying a portion of the inlet gas before condensing (reflux enhancement).

Gas composition has an effect on the amount of compression horsepower required; richer gas generally requires more horsepower to achieve the same recovery level than a leaner gas because of having more heavy components. As inlet pressure decreases, more heat transfer area is required to achieve the same recovery level inside the cold box; this is largely due to the higher temperature driving force available at the higher pressure. More exchanger area is required for ethane recovery than for propane recovery due to the higher amount of energy that must be transferred to cool the gas to the required temperatures.

Obtained values from simulation by *Aspen Hysys* software (ver.2006) were compared with specified values of manufacturer as product specification, as Table 1 shows most calculated values are in good agreement with defined limit except Hydrogen sulfide content in export gas, but whereas this value is trace it's considered negligible. The de-methanizer column bottom temperature is controlled to provide a typical C₁:C₂ NGL product specification, while the de-ethanizer column bottom temperature is set to provide a typical C₂:C₃ LPG product specification thus operational temperature for reboiler of each column in order to catch these properties is 40°C, 109°C and according to LP steam condition (155°C, 3.5 barg) used steam values are almost 3855 kg/hr and 9971 kg/hr respectively.

TABLE I
COMPARISON OF EXPORT GAS AND ETHANE PRODUCT SPECIFICATION WITH SIMULATED VALUES

Components	Export gas specification		Ethane gas specification	
	Specified value	Simulated values	Specified value	Simulated values
Methane	Min. 80% mol.	93.5% mol.	Max. 0.94% mol.	0.35% mol.
Ethane	Max. 12% mol.	1.92% mol.	Min. 94% mol.	95% mol.
Propane	Max. 4% mol.	0.05% mol.	Max. 0.6% mol.	0.21% mol.
Butane	Max. 1% mol.	42 PPM mol.	Max. 3PPM mol.	Nil
C ₅₊	Max. 0.5% mol.	< 0.02 % mol.		
Carbon dioxide	Max. 1% mol.	0.69% mol.	Max. 4.4% mol.	4.4% mol.
Nitrogen	Max. 6% mol.	3.82% mol.	-	Nil
H ₂ S	Max. 5 mg/Nm ³	1PPm mol.	Max. 74 PPM mol.	48 PPM mol.
Mercaptans	Max. 15 mg/Nm ³	Nil		

According to calculated data of Table 1, they have good coincidence with average results of some laboratory analysis so that not only all experimental data are in defined limit but are similar to simulated values. For Ethane product, summation of both Butane and C₅₊ and also H₂S and Mercaptan has been considered in one row. Fig. 4 represents amount of light components mole fraction based on tray position from bottom to up so Ethane percent is rising toward top of de-ethanizer column.

Carbon dioxide falls between methane and ethane in terms of relative volatility but unfortunate consequence of this matter is that high ethane recovery in a typical NGL recovery plant often leads to high CO₂ concentrations in the NGL product (C₂₊) thus this must be treated to remove CO₂ as a result of purchaser's specifications.

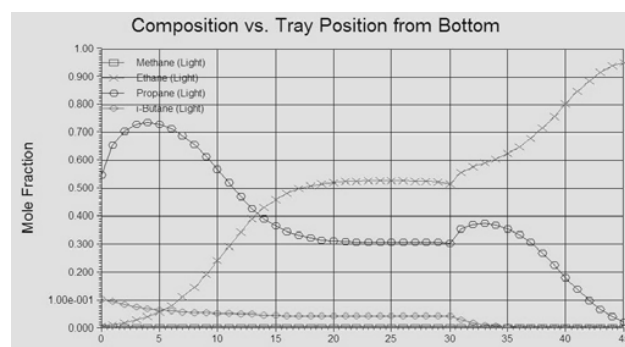

Fig. 4 Light components mole fraction versus tray position in de-ethanizer column

In theory, heating value is simply the heat evolved on combustion but in practice the situation is complicated by the use of many bases; higher (Gross) or lower (Net); wet or dry [4]. Generally, heating value is defined as the extracted heat when fuel is completely burned at some specified or standard condition usually 15°C and 1 atm. When fuels containing hydrogen are burned the condition of produced water (liquid or vapor) by combustion must be specified. For higher heating value (HHV) is assumed that all produced water by combustion leaves system as condensate liquid so for lower heating value (LHV) is assumed it's as vapor or steam thus difference between them is water vaporization heat [5]. The *Wobbe Index* (WI) or *Wobbe number* is an indicator of the interchangeability of fuel gases such as natural gas, liquefied petroleum gas, and Town Gas and is frequently defined in the specifications of gas supply and transport utilities. If *HHV* is the higher heating value, or calorific value, and *Sp.Gr* is the specific gravity, the Wobbe Index is defined as [6]:

$$WI = \frac{HHV}{\sqrt{Sp.Gr}} \quad (1)$$

Table 2 indicates heating values of each of Export gas and Ethane products.

Although most gas transportation companies and gas consumers will accept Carbon dioxide concentration in less than one percent for natural gas streams, but many NGL recovery processes and petrochemical plants which receive Ethane as feedstock require removal of CO₂ to avoid troubles. Since CO₂ removal equipment can add significantly to both the investment and operating costs of the contaminant removal section of the gas processing facility, there is considerable advantage to reduce the CO₂ content in product leaving the liquids recovery section of an NGL recovery facility. Carbon dioxide freezing was estimated by calculating CO₂ freezing temperature approach (ΔT_{CO_2}). This temperature is calculated based on composition and pressure. Negative value of ΔT_{CO_2} indicates a CO₂ freezing problem most likely will occur.

$$\Delta T_{CO_2} = T_{oper.} - T_{CO_2,freeze} \quad (2)$$

In this unit, a portion of the ethane (1.92% by mole) is introduced into the export gas stream before compression by export compressor to pipeline; this allows to easily fix the heating value of the sales gas (36.66 MJ/Nm³) to provide pipeline quality gas at the most economical conditions.

TABLE II
CALCULATED VALUES BY ASPEN HYSYS FOR SOME PROPERTIES OF EXPORT AND ETHANE PRODUCT

Properties	Export Gas	Ethane	Ethane after CO ₂ removal
Lower Heating value (MJ/Nm ³)	33.03	58.20	60.91
Higher Heating value (MJ/Nm ³)	36.66	63.63	66.59
Wobbe Index (MJ/Nm ³)	47.84	61.59	65.11
Hydrocarbon dew point @ Export Pressure (°C)	-	7.05	8.05
Hydrate formation temperature @ Export Pressure (°C)	15.3	14.78	14.6
CO ₂ freeze temperature (°C)	-131.3	-104.5	-

Fig.5 shows boiling point curves of simulated export gas product while Fig.6 indicates boiling point curve of ethane stream accordance to different ASTM standards. ASTM D86 and D1160 distillations employ batch fractionation apparatus but they are conducted using non-refluxed Engler flasks. ASTM D86 is used for light to medium petroleum fluids e.g. Methane and Ethane so ASTM D1160 is carried out at both vacuum and atmospheric conditions for heavier products.

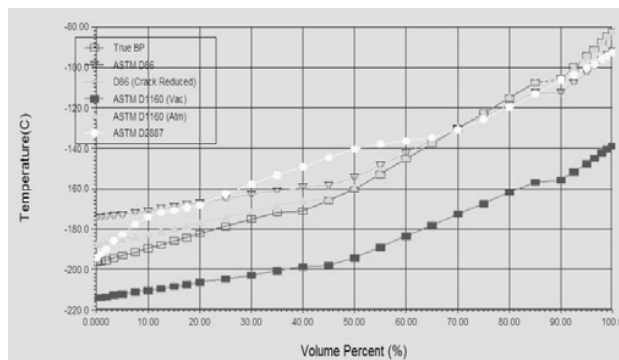

Fig. 5 Boiling point curves of produced export gas based on ASTM standards

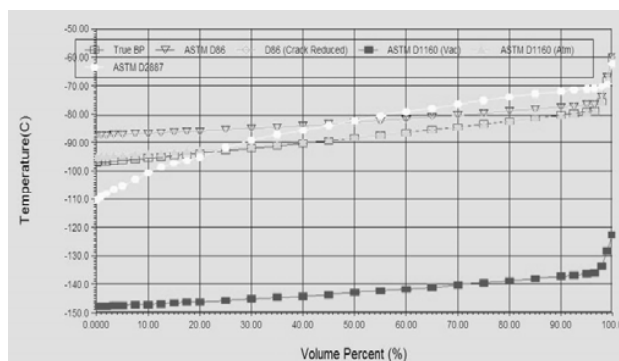

Fig. 6 Boiling point curves of produced ethane gas based on ASTM standards

ACKNOWLEDGMENT

The authors thank the gas refinery laboratory staff for giving required data to investigate simulation results.

REFERENCES

- [1] K.A. Pennybaker, S.E. Wolverton, "A comparative study of ethane recovery processes", *River city Engineering, Inc.*, Kansas.
- [2] H.M. Hudson, J.D. Wilkinson, "Reducing treating requirements for cryogenic NGL recovery plants", *80th annual convention of the Gas processors association*, Texas, USA, 2001.
- [3] H.M. Hudson, J.D. Wilkinson, "Next generation processes for NGL/LPG recovery", *77th annual convention the Gas processors association*, Texas, USA, 1998.
- [4] D.Y. Peng, D.B. Robinson, A new two-constant equation of state, *Ind. Eng. Chem. Fundam.* 15, 59-64, 1976.
- [5] A. Esmaili, Experimental study and steady state simulation of a NGL fractionation unit in order to investigate qualified specification, *19th International Congress of Chemical and Process Engineering (Chisa2010)*, Prague, Czech Republic, 2010.
- [6] A. Esmaili, Experimental study and steady state simulation of a LPG production unit to investigate specified properties, *13th Asian Pacific confederation of chemical engineering congress*, Taipei, Taiwan, 2010.