

# Single Port Overlay Cognitive Radio Using Reconfigurable Filtennas

V. Nagaraju, Tapas Bapu. B. R, Beryl J. Victor

**Abstract**—In this paper cognitive radio is presented and the spectrum overlay cognitive radio antenna system is detailed. A UWB antenna with frequency reconfigurable characteristics is proposed. The reconfigurability is achieved when the filter is integrated to the feeding line of the single port overlay cognitive radio. When activated, the filter can transform the UWB frequency response into a reconfigurable narrowband one, which is suitable for the communication operation of the CR system. Here single port overlay cognitive radio antenna is designed and simulated using Ansoft High Frequency Structure Simulator (HFSS).

**Keywords**—band-pass filter, Cognitive radio, filtenna, frequency reconfigurable, ultra-wideband antenna.

## I. INTRODUCTION

AN increasing demand for radio spectrum has resulted from the emergence of feature-rich and high-data-rate wireless applications. The spectrum is scarce and the current radio spectrum regulations make its usage inefficient. This necessitates the development of new dynamic spectrum allocation policies to better exploit the existing spectrum. According to the current spectrum allocations, specific bands are assigned to particular services and only licensed users are granted access to licensed bands. Cognitive radio (CR) is expected to revolutionize the way spectrum is allocated. In a CR network, the intelligent radio part allows unlicensed users (secondary users) to access spectrum bands licensed to primary users, while avoiding interference with them. Cognitive radio is one of the most promising techniques to efficiently utilize the radio frequency (RF) spectrum (7.4GHz). Based on the type of available network side information along with the regulatory constraints, secondary users seek to underlay and overlay or interweave their signals with those of primary users without significantly impacting these users.

A cognitive radio is a wireless communication device that intelligently utilizes any available side information about the (a) activity, (b) channel conditions, (c) encoding strategies or (d) transmitted data sequences of primary users with which it shares the spectrum. Cognitive radio (CR) technology is key enabling technology which provides the capability to share the wireless channel with the licensed users in an opportunistic way. In order to share the spectrum with the licensed users

without interfering with them, and meet the diverse quality of service requirements of applications, each CR user in a CR network must:

- Determine the portion of spectrum that is available, which is known as Spectrum sensing.
- Select the best available channel, which is called Spectrum decision.
- Coordinate access to this channel with other users, which are known as Spectrum sharing.
- Vacate the channel when a licensed user is detected, which is referred as Spectrum mobility.

To fulfill these functions of spectrum sensing, spectrum decision, spectrum sharing and spectrum mobility, a CR has to be cognitive, reconfigurable and self-organized. An example of the cognitive capability is the CR's ability to sense the spectrum and detect spectrum holes (also called white spaces), which are those frequency bands not used by the licensed users. The reconfigurable capability can be summarized by the ability to dynamically choose the suitable operating frequency (frequency agility), and the ability to adapt the modulation/coding schemes and transmit power as needed. The self-organized capability has to do with the possession of a good spectrum management scheme, a good mobility and connection management, and the ability to support security functions in dynamic environments. Based on the type of available network side information along with the regulatory constraints, secondary users seek to underlay, overlay, or interweave their signals with those of primary users without significantly impacting these users. In this paper we describe the design requirements of software controlled antenna system for spectrum overlay cognitive radio.

In the interweave mode of operation, the cognitive radio searches for the unoccupied part of the spectrum (white spaces/spectral gaps) and transmits without any power constraint. The primary and secondary signals do not interfere with each other. The secondary users may then fill in these spectral gaps. For the underlay approach, the secondary users transmit over the same spectrum as the primary users, but do so in a way that the interference seen by the primary users from the cognitive users is controlled to an acceptable level. The secondary user requires knowledge of the acceptable levels of interference at primary users' transmission range.

The spectrum overlay approach, also termed opportunistic spectrum access (OSA) or dynamic spectrum access (DSA), imposes restrictions on when and where secondary users may transmit rather on their transmission power. In this approach, the secondary users transmit over the same spectrum as the primary users, but in addition to knowledge of the channels

V.Nagaraju is with S.A. Engineering College, Chennai, India (phone: +91-9840873669, e-mail: nagaraj159@gmail.com).

Tapas Bapu.B.R is with S.A. Engineering College, Chennai, India (phone: +91-9884179733, e-mail: tapasbapu@saec.ac.in).

Beryl J Victor is with S.A Engineering College, Chennai, India (e-mail: berylvictor@gmail.com).

between primary and secondary users, the cognitive nodes have additional information about the primary system and its operation. The secondary users avoid higher priority users through the use of spectrum sensing and adaptive allocation. They identify and exploit the spectrum holes defined in space, time, and frequency. Fig. 1 describes the communication between primary and secondary users over the same channel by eliminating the interference between them.

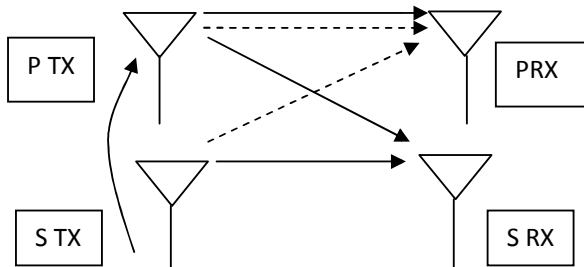

Fig. 1 The primary users and secondary users wish to transmit over the same channel. Solid lines denote desired transmission and the dotted lines denote interference

Frequency reconfigurable antennas are essential for cognitive radio systems. Designing a frequency reconfigurable antenna requires appropriate integration of various switching components into the antenna structure. Most researchers incorporate switches such as PIN diodes, RF MEMS, varactors into the radiating surface of the antenna [1]–[6]. This constitutes a challenge since extensive care has to be taken when designing and placing the biasing lines to avoid their effects on the antenna radiation characteristics. Reconfigurable filtennas have also been introduced as a solution to avoid placing the switching components on the radiating antenna part but rather in the antenna’s feeding line or ground plane [7]. A filtenna is the combination of a filter and antenna. The filter consists of Defected Microstrip structure [10]–[14]. Usually the filter is integrated within the feeding line of the antenna or in its ground plane [8], [9]. By utilizing filtennas, the negative effects of the biasing lines are reduced and the antenna radiating edges are not disturbed. This will ensure a minimal fluctuation in the antenna radiation characteristics.

This paper is divided into the following sections. In Section II A, a reconfigurable band pass filter for the overlay cognitive radio case is presented. A single port overlay CR antenna is detailed in Section II B. Simulation results are drawn for cognitive radio antenna system in Section II D. Concluding remarks and future work constitutes Section III.

II. ANTENNA DESIGN CONFIGURATIONS

A. Bandpass-Filter Configuration

This design has a reconfigurable filter i.e. bandpass filter consisting of Defected Microstrip structure (DMS). Filter is of T shaped slot with length 9mm and this filter has two band gaps beside the slot of width 0.25mm each. This gaps in this filter acts as band-pass characteristics acting as a parallel-series resonance. Antenna structure wholly is printed on the

Rogers Duroid 5880 substrate which has dielectric constant  $\epsilon_r=2.2$  and with height 1.6mm. The total dimension of the filter is 15×30 mm. The physical structure of the filter is shown in Fig. 2 and its corresponding simulated S-parameters are summarized in Fig. 6. From Fig. 6, we conclude that this structure behaves as a band-pass filter at 7.4 GHz.

The band-pass filter modifies its operating frequency by changing the length of the T-shaped slot in the middle subsection. This can be done by incorporating two PIN diodes (S1 & S2) within the T-shaped slot. The switches are operated in pairs from the edges of the T-slot. Mainly switches are used to switch between slots which reconfigure frequency and act as band-pass filter.

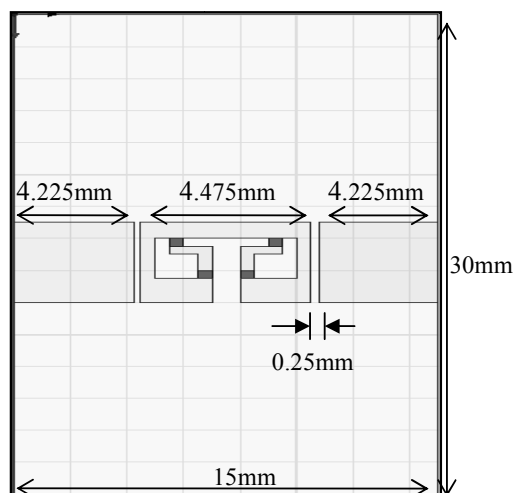

Fig. 2 Top section of Band pass filter

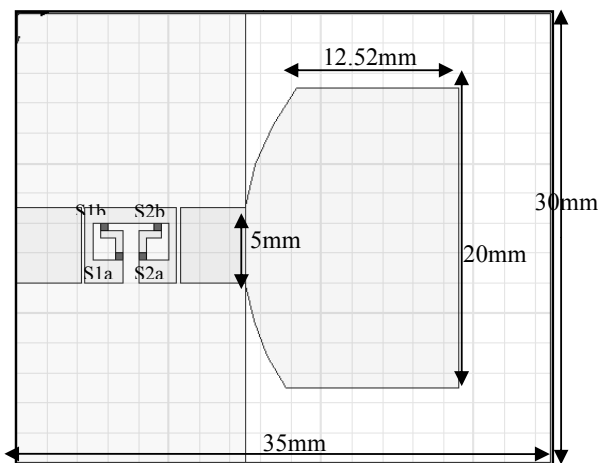

Fig. 3 Top section of single port overlay CR antenna

B. Single Port Overlay Cognitive Radio Antenna

Dual-port antennas enable simultaneous sensing and communicating over the channel, but have limitations in terms of their larger size and the coupling between the two ports and also the degraded patterns. These limitations are solved by the use of single-port antennas. The total dimensions of the single port overlay antenna system are 35×30mm<sup>2</sup>. The

reconfigurable filtennas consist of a partial ground of dimensions  $15 \times 30 \text{mm}^2$ . The feeding line of filtenna contains the reconfigurable band-pass filter with the same dimensions and the same number of switches as discussed previously in part A of Section II. The configuration of the antenna is shown in Fig. 3.

It features a partial rectangular ground plane, a rectangular patch, and a curved matching section between the microstrip feed line and the patch. The radiating patch of the reconfigurable filtennas consists of a modified printed monopole of length 20 mm. A curved matching section between the microstrip feed line and the patch is formed by a circular shaped contour whose radius is 17.2mm. For the purpose of achieving frequency reconfigurability, pair of gap is symmetrically placed around the T-slot, and switches S1 and S2 are placed across the slots as shown in Fig. 2. Two switching cases are considered, as indicated in Table I. Case 0 corresponds to all the switches being ON. In case 1, the effect of the filter is canceled, bringing back the UWB response of the antenna. The frequency characteristics of the filter depend on the dimensions of the slots, and on the switching state.

### C. Antenna Design Equations

The single port overlay antenna system is designed with the dimension of  $50 \times 30 \text{mm}^2$ . The frequency of operation for the patch antenna design is selected as 2.4 GHz. The dielectric material used for the antenna is Rogers Duroid 5880 with  $\epsilon_r = 2.2$  as this one of the maximum values of the dielectric substrate has been taken in order to reduce the size of the antenna. Single port overlay antenna has been designed in order to rule out the conventional antenna as the antenna is to be used in most of the compact devices. Hence the height of the antenna has been used as 1.6mm.

$$f_0 = 2.4 \text{GHz}, \epsilon_r = 2.2, h = 1.6 \text{mm} \quad (1)$$

The width of the antenna is calculated by substituting  $f_0 = 2.4 \text{GHz}$ ,  $h = 1.6 \text{mm}$ ,  $c = 3 \times 10^8 \text{m/s}$  in (2):

$$w = \frac{c}{2f_0} \sqrt{\frac{2}{\epsilon_r + 1}} \quad (2)$$

From (2) width is derived as 29.2mm and the effective dielectric constant  $\epsilon_{r\text{eff}}$  is calculated from (3):

$$\epsilon_{r\text{eff}} = \frac{\epsilon_r + 1}{2} + \frac{\epsilon_r - 1}{2} \left[ 1 + \frac{12h}{w} \right]^{1/2} \quad (3)$$

With the value of effective dielectric constant  $\epsilon_{r\text{eff}}$  as 8.89 effective lengths  $L_{\text{eff}}$  is derived from (4):

$$L_{\text{eff}} = \frac{c}{2f_0 \sqrt{\epsilon_{r\text{eff}}}} \quad (4)$$

Thus the length of the patch  $L$  is given by (5) by substituting the values of  $L_{\text{eff}} = 15 \text{mm}$

$$L = L_{\text{eff}} - 2\Delta L \quad (5)$$

Hence the length of the patch is derived as  $29.2 \text{mm} \approx 30 \text{mm}$  from (5).

TABLE I  
SWITCHING CASES OF THE ANTENNA

Cases	Switch(S1,S2)	Frequency(GHz)	Gain(dB)
Case 0	All ON	7.4 GHz	-17.40dB
Case 1	S1(off), S2(on) S1(on), S2(off)	Can be measured after hardware implementation.	

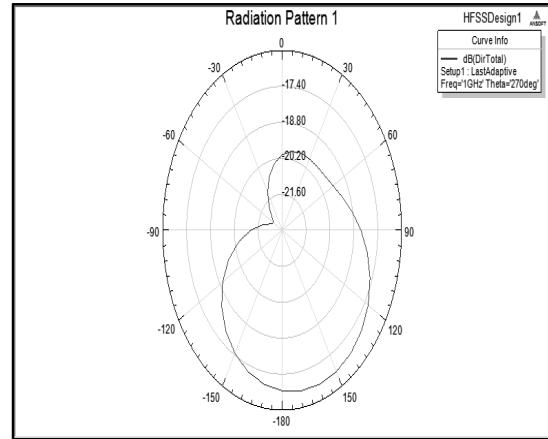

Fig. 4 Radiation pattern of proposed antenna

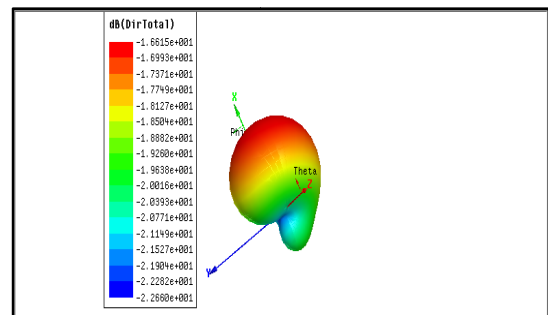

Fig. 5 3D polar view of proposed antenna

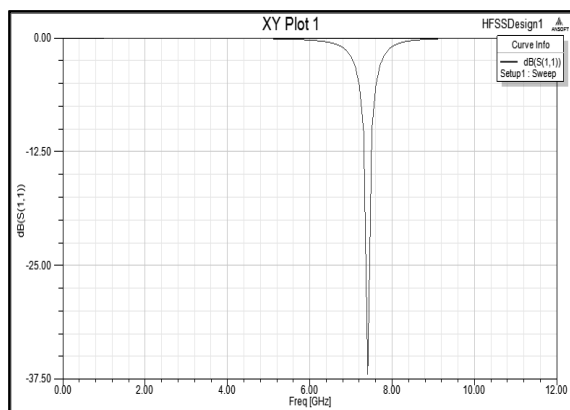

Fig. 6 Simulated return loss of the antenna when the filter in ON

#### D. Simulation Results

When the band-pass filter is activated, then the antenna acts as a UWB antenna and the plot of the case 0 i.e. when filter is ON allows all band of frequency that is shown in Fig. 6. Fig. 4 shows the radiation pattern, whereas Fig. 5 shows the 3D polar view of the antenna. Switching the pin diodes can be measured only after implementation of the antenna in hardware. Table I describes the switching of filter under different cases.

#### III. CONCLUSION

In this paper, overlay cognitive radio is discussed. UWB antennas are required for sensing in overlay CR, and for communicating in underlay CR. Modified UWB antennas with reconfigurable band notches allow to employ UWB technology in overlay CR and to achieve high-data-rate and long distances communications. Overlay CR requires reconfigurable wideband/narrowband antennas, to perform the two tasks of sensing a wide band and communicating over a narrow white space. UWB antennas especially single-port wide-narrowband antennas suitable for these approaches have been proposed

#### IV. FUTURE WORK

The main purpose of adopting cognitive radio technology is to improve the spectrum usage efficiency by monitoring the channel activity and searching for unoccupied parts of the spectrum. This spectral efficiency degrades in a rich multipath environment. Therefore, it is essential to adopt MIMO based diversity techniques for both cognitive radio systems in order to combat fading and ensure reliable communication between the end users. The "overlay" antenna system presented in this paper consists of 2 elements MIMO that are able to change their notch frequency correspondingly. The combination of both MIMO and cognitive radio technology maximize both the spectrum efficiency and utilization.

#### REFERENCES

- [1] Grau, J. Romeu, M. Lee, S. Blanch, L. Jofre, and F. De Flaviis, "A dual linearly polarized MEMS-reconfigurable antenna for narrowband MIMO communication systems," *IEEE Trans. Antennas Propag.*, vol. 58, no. 1, pp. 4–16, Jan. 2010.
- [2] S. Nikolaou, N. D. Kingsley, G. E. Ponchak, J. Papapolymerou, and M.M. Tentzeris, "UWB elliptical monopoles with a reconfigurable band notch using MEMS switches actuated without bias lines," *IEEE Trans. Antennas Propag.*, vol. 57, no. 8, pp. 2242–2251, Aug. 2009
- [3] C. R. White and G. M. Rebeiz, "Single and dual-polarized tunable slot-ring antennas," *IEEE Trans. Antennas Propag.*, vol. 57, no. 1, pp.19–26, Jan. 2009.
- [4] J. Perruisseau-Carrier, P. Pardo-Carrera, and P. Miskovsky, "Modeling, design and characterization of a very wideband slot antenna with reconfigurable band rejection," *IEEE Trans. Antennas Propag.*, vol. 58, no. 7, pp. 2218–2226, Jul. 2010.
- [5] G. H. Huff and J. T. Bernhard, "Integration of packaged RF-MEMS switches with radiation pattern reconfigurable square spiral microstrip antennas," *IEEE Trans. Antennas Propag.*, vol. 54, no. 2, pp. 464–469, Feb. 2006.
- [6] N. Jin, F. Yang, and Y. Rahmat-Samii, "A novel patch antenna with switchable slot (PASS): Dual-frequency operation with reversed circular polarizations," *IEEE Trans. Antennas Propag.*, vol. 54, no. 4, pp. 1031–1043, Mar. 2006.
- [7] Y. Tawk, J. Costantine, and C. G. Christodoulou, "A varactor based reconfigurable filtenna," *IEEE Antennas Wireless Propag. Lett.*, vol.11, pp. 716–719, 2012.
- [8] M. R. Hamid, P. Gardner, P. S. Hall, and F. Ghanem, "Vivaldi antenna with switchable band pass resonator," *IEEE Trans. Antennas Propag.*, vol. 59, no. 11, pp. 4008–4015, Nov. 2011.
- [9] B. E. Carey-Smith and P. A. Warr, "Broadband-configurable band-stop filter design employing a composite tuning mechanism," *Microwaves, Antennas Propag., IET*, vol. 1, no. 2, pp. 420–426, Apr. 2007.
- [10] Abu Tarboush H.F, Khan S, NilavalanR, Al-Raweshidy H.S, Budimir D (2009) Reconfigurable Wideband Patch Antenna for Cognitive Radio. Proceedings of the 2009 Loughborough antennas and propagation conference (LAPC 2009), Loughborough, UK. 16–17 Nov 2009. Pp.141–144.
- [11] Hamid M.R, Gardner P, Hall P.S, Ghanem F (2011) Switched-band Vivaldi Antenna IEEE transactions on antennas and propagation. 59:5:1472–1480.
- [12] Hamid M.R, Gardner P, Hall P.S, Ghanem F (2011) Vivaldi Antenna with Integrated Switchable Band Pass Resonator. IEEE transactions on antennas and propagation.59:11:4008–4015.
- [13] Al-Husseini M, Ramadan A, Zamudio M.E, Christodoulou C.G, El-Hajj A, Kabalan K.Y(2011) A UWB Antenna Combined with a Reconfigurable Bandpass Filter for Cognitive Radio Applications. Proceedings of the 2011, IEEE-APS Topical Conference on Antennas and Propagation in Wireless Communications (IEEE APWC 2011). Torino, Italy. 12–16 Sep 2011. pp. 902–904.
- [14] Kazerooni M, Cheldavi A, Kamarei M (2009) A Novel Bandpass Defected Microstrip Structure (DMS) Filter for Planar Circuits. Proceedings of the 2009 Progress in Electromagnetics Research Symposium (PIERS 2009). Moscow, Russia. 18–21 Aug 2009. pp. 1214–1217.