

# Simulation of CO<sub>2</sub> Capture Process

K. Movagharnjad and M. Akbari

**Abstract**—Carbon dioxide capture process has been simulated and studied under different process conditions. It has been shown that several process parameters such as lean amine temperature, number of adsorber stages, number of stripper stages and stripper pressure affect different process conditions and outputs such as carbon dioxide removal and reboiler duty. It may be concluded that the simulation of carbon dioxide capture process can help to estimate the best process conditions.

**Keywords**—Absorption, carbon dioxide capture, desorption, process simulation.

## I. INTRODUCTION

GLOBAL warming as a consequence of increased atmospheric carbon dioxide concentration is considered as one of the most important environmental problems that world faces today. Carbon dioxide capture process has both industrial and environmental points [1]. Acceptable extent of carbon dioxide in treated gas for environmental regulations varies in different sources. For example for coal power plants that should be less than 1.5% [2]. Several technologies have been developed to capture carbon dioxide from the flue gases. Numerous methods exist for the post-combustion capture of Carbon dioxide from flue gases including Chemical absorption, Physical absorptions, Membrane separation, Adsorption, Cryogenic separation [3]. Chemical absorption systems are usually preferred in present time. The most common solvents used for CO<sub>2</sub> removal from low pressure flue gas are alkanol amines such as methyl ethyl amine (MEA), diethyl amine (DEA) and diglycol amine (DGA) [4]. The process for carbon dioxide capture using MEA consists of 3 different sections. The first section is the cooling and compression of the flue gas. Absorption of carbon dioxide and regeneration of the solvent consist the second stage. The final stage would be the carbon dioxide compression. Currently, amine scrubbing process is considered the most important method to capture carbon dioxide from low-pressure flue gases. This process involves of the chemical reaction between carbon dioxide and the liquid solvents. The chemical absorbents are usually aqueous solutions of primary, secondary and tertiary alkanol amines, di isopropanol amine, sodium carbonate and potassium carbonate [5]. Flue gases and engine exhausts have very low carbon dioxide concentrations of typically 3 to 15 vol%. The only commercial absorbents for capture of dilute carbon dioxide from atmospheric pressure

K. Movagharnjad is with the Babol University of Technology, P.O. Box 484, Babol, Iran. (phone: +98-111-3234204; fax: +98-111-3234204; e-mail: movagharnjad@yahoo.com).

M. Akbari, was a MS student of Babol University of Technology, P.O. Box 484, Babol, Iran.

flue gases are MEA and other primary amines.

## II. AMINE SCRUBBING PROCESS

The amine scrubbing process has two main sections, which are called absorption and desorption sections. Carbon dioxide is separated from the flue gas by passing through a continuous scrubbing system consisting of an absorber and a desorber (stripper). In the desorber, the absorbed carbon dioxide is stripped from the solution. A concentrated stream of carbon dioxide is sent for compression and the regenerated solvent is sent back to the absorber. A reboiler at the bottom of the stripper column provides the steam in order to establish the required driving force for carbon dioxide stripping from the solvent. The condenser at the top of the column provides cooling. A part of the liquid reflux is returned to the top of the desorber column while a purge stream is sent to storage. This removal process consumes a large amount of energy, thus one of the main aims of this study is to minimize this energy consumption. Energy is also required to compress the carbon dioxide to high pressures needed for storage. It is desired to investigate and understand which parameters (e.g.: temperature, pressure, concentration, hydrodynamics) which affect the performance of this process. The different parameters can be optimized in order to improve the overall performance. In this work we have simulated the typical amine absorption process for the flue gas of a local cement factory. The properties of this flue gas are given in table 1.

TABLE I  
THE PROPERTIES OF THE FLUE GAS

	Flue Gas	CO <sub>2</sub>	H <sub>2</sub> O	N <sub>2</sub>	O <sub>2</sub>
<b>Mass Flow</b> (tone/hr)	1220	264	36	728	192
<b>Mass Fraction</b>	100 %	22 %	3 %	60 %	15 %
<b>Volume Flow</b> (m <sup>3</sup> /hr)	16700	2500	830	10800	2500
<b>Molar Flow</b> (kmol/hr)	40 000	6000	2000	2600	2000
<b>Mole (%)</b>	100 %	15 %	5 %	65 %	15 %

The typical flowchart for the simulation, with aid of software, is shown in Fig. 1. The aim of this paper is to find the optimum values of lean amine temperature, height of the columns and minimize the energy consumptions. Because testing the process at large scale is so expensive, it is reasonable to make use of process simulation software to evaluate such processes [6]. These software are used to

simulate the carbon dioxide capture process designed for the exhaust gas from a local cement producing plant. Heat losses and some pressure losses are neglected. A real process contains more equipment, pipes and valves, and all of these equipments also have heat and pressure losses.

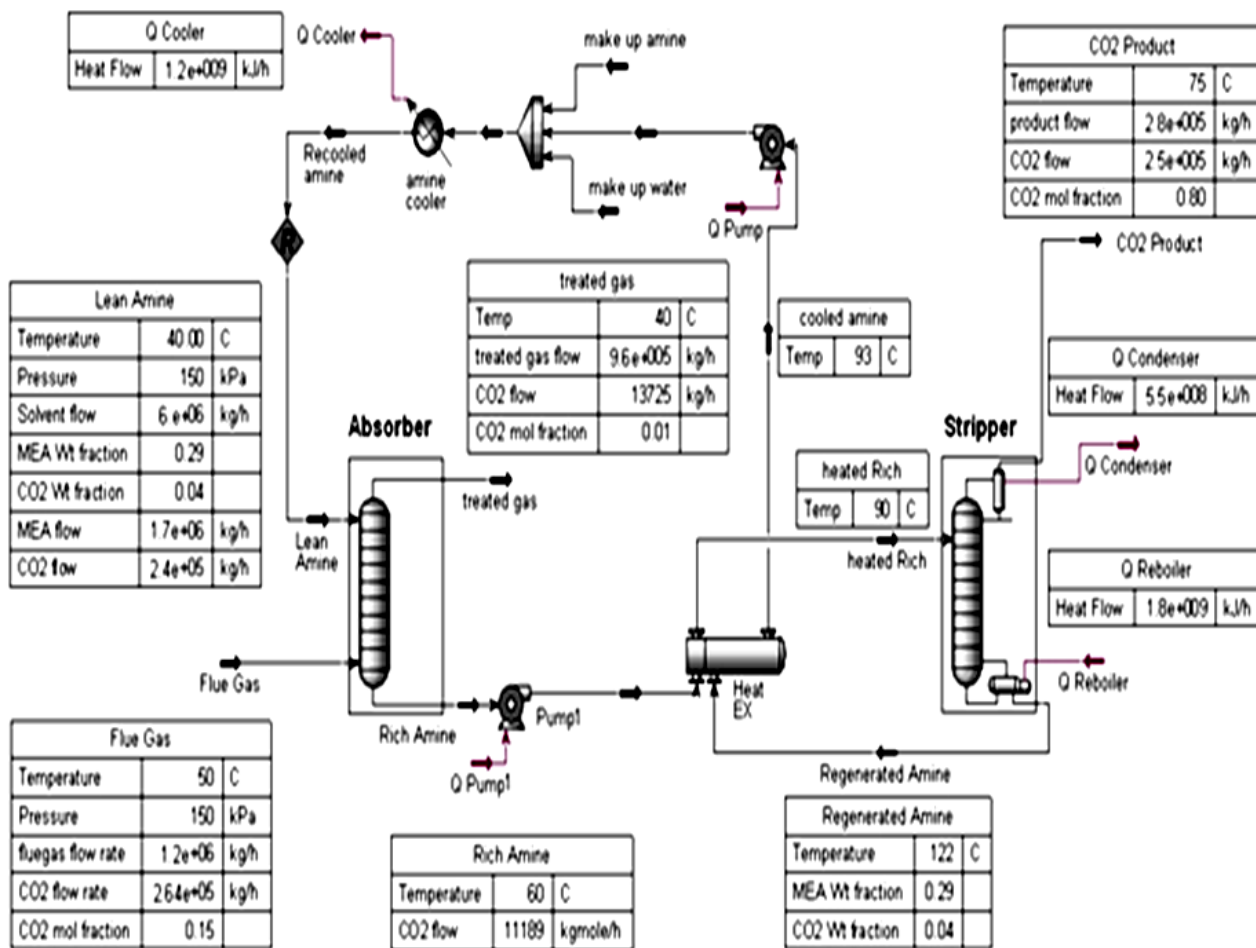

Fig. 1 Flow diagram of the amine separation process

### III. RESULTS AND DISCUSSIONS

The simulation package was used in several situations to study the influence of different process parameters. The results are summarized in following figs. According to the fig. 2, separation will increase by decreasing lean loading. But variation of lean amine temperature indicates that there is an optimum value related to lean loading. Thus with increasing the lean loading the optimum lean temperature will be reduced. In this fig. which is run for value of 6000 ton per hour of solvent, the parameter "a" means carbon dioxide loading which can be defined by the following formula:

$$\text{CO}_2 \text{ Loading} = \frac{\text{Moles of all CO}_2 \text{ carrying species}}{\text{Moles of all MEK carrying species}} \quad (1)$$

In fig. 2, three different cases of  $a=0$ ,  $a=0.17$  and  $a=0.24$  are shown. It is also clear that the carbon dioxide removal decreases with increase of the parameter "a". This fact may be related to the fact the carbon dioxide removal may be more difficult for higher carbon dioxide loadings.

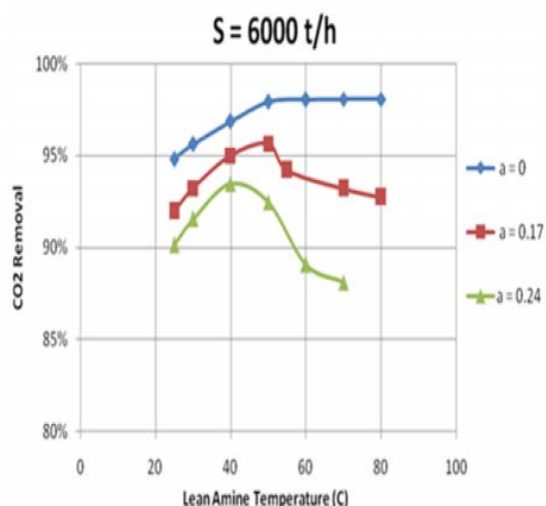

Fig. 2 Variation of CO<sub>2</sub> removal with lean temperature and lean loading

The height of absorber tower is an important parameter that affects the process cost and performance. So we have tried to simulate the effect of the increase of tower height on the removal rate of the carbon dioxide. As the tower height is directly proportional to the number of stages (trays), the simulation process is based on the number of stages which are whole numbers.

In order to study the effect of the absorber height on carbon dioxide removal, the diameter of the column was kept constant and the absorber height (number of stages) was varied. As was expected, with increase in the absorber height, carbon dioxide separation increased but the increase in height of the absorber would also increase additional costs which are listed in the following sentences:

1. *Capital cost:* As the height of the absorber tower increases, the capital cost of the equipment also rises. It also have to be noted that there some limits for the maximum height of every distillation towers. This maximum height depends on tower diameter, tower material and type and even the weather conditions and climate of the location.

2. *Power cost required in blower:* The pressure drop in the absorber increases as the height of the absorber increases and hence, the power required in the blower will increase. It have to be noted that each equipment has a maximum allowable pressure drop which cannot be exceeded. Higher pressure drops may change the thermodynamic conditions or flow of the fluids.

Fig. 3 shows the results for this case. In this fig. we have three different carbon dioxide loadings of 0, 20 and 0.28.

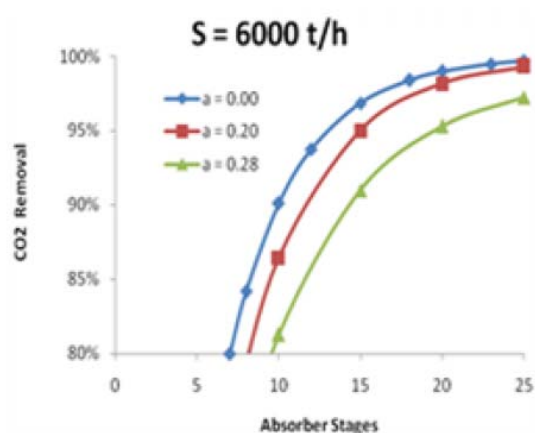

Fig. 3 Effect of number of stages

The height of the desorber tower is also an important parameter. The facts discussed for the absorber tower in the previous paragraph are also valid for this tower. Reboiler heat duty of this tower is an important technical and economical factor for whole of the carbon dioxide removal process. The absorber height and diameter and the desorber diameter were kept constant and the effect of desorber height on the reboiler duty was studied. It was found that the effect of the desorber height on the reboiler height was not very significant except at very low heights at which the desorber heat duty was very high.

Fig. 4 shows the variation of the reboiler duty with stripper (desorber stages). It shows that increase of the stages sharply decreases the reboiler heat duty but after this sharp reduction, the reboiler duty seems to reduce slightly for higher number of stages. In this fig. the reboiler duty for 95% carbon dioxide recovery is simulated. The solvent rate is considered 6000 t/hr and the "a" factor is considered to be equal to 0.2.

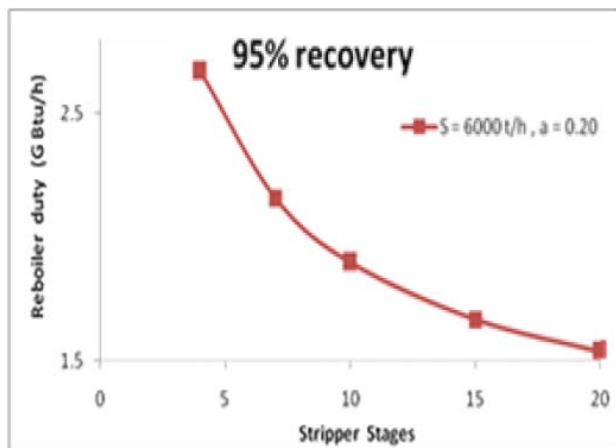

Fig. 4 The effect of stripper stages on reboiler duty

The pressure in the reboiler has a significant effect on the performance of the process. The pressure increase in the reboiler is accompanied by an increase in the temperature. As the temperature increases, the conditions become favorable for transfer of carbon dioxide to the gas phase and hence, less steam is required to maintain the driving force for carbon dioxide transfer. Thus, it is favorable to operate the desorber at high pressures and temperatures as possible. However, the operating conditions in the desorber are limited by the fact that the degradation of MEA is accelerated with increasing temperatures so a temperature of greater than 125°C in the reboiler is not recommended [7]. At the other hand increasing the pressure is always costly. High pressure vessels have to be manufactured from different and usually more expensive materials. So there is always a maximum limit for temperature or pressure in the desorber tower. The desorber needs to be operated at a pressure that corresponds to a temperature of 125°C or less in the reboiler. Fig. 5 shows the reboiler duty versus stripper pressure. In this case we have considered the 95% recovery for carbon dioxide for the solvent rate of 6000 t/hr which is the same as fig. 4. The pressure is varied from 1 to 2.5 bar. It is clear that the reboiler duty reduces sharply as the pressure increases from 1 to 1.5 bar, but the reduction in reboiler heat duty is not so sharp as the pressure increases from 2 to 2.5 bar. So increasing the pressure is not justified after reaching a certain optimum quantity.

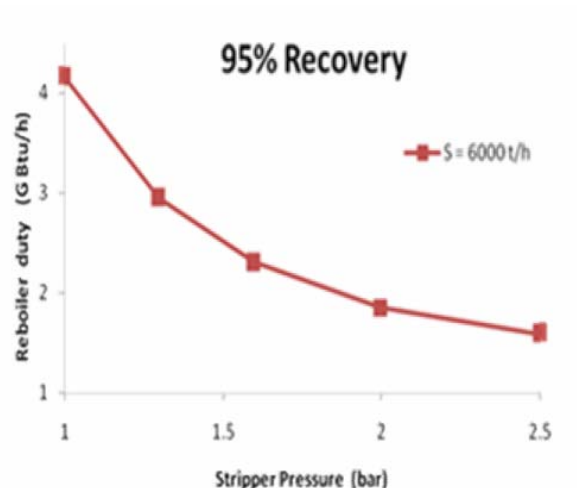

Fig. 5 Reboiler duty versus stripper pressure

These different simulations which are discussed in brief here, may help to find optimum process conditions. By the term “optimum conditions”, we mean the achievement of standard carbon dioxide separation and compression by a minimum cost. Some suggestions about these optimum conditions are listed in the following section.

#### IV. CONCLUSION

The main of this study is to build a framework and preliminary design for carbon dioxide capture process for potential carbon dioxide capture processes in Iran. So different process factors are selected and studied in order to see their effects on process performance. Some important results have been obtained by discussing the results of the computer simulations that are described in the following sentences. These points may help to reduce the costs or improve the quality of the real processes.

*It may be concluded from this study that:*

1. There is an optimum temperature for lean amine temperature which is usually between 40 and 60 C.
2. Increasing the number of absorber stages to approximately 15 stages improves the extent of CO<sub>2</sub> removal, but after that increasing the number of stages does not show a sharp effect.
3. Increasing the reboiler pressure reduces the reboiler duty but it may also increase the column cost.
4. Increasing the reboiler pressure also decreases the reboiler duty but this increase in pressure is limited by the probability of amine degradation.

REFERENCES

- [1] C. M. White, B. R. Strazisar, "Separation and Capture of CO<sub>2</sub> from Large Stationary Sources and Sequestration in Geological Formations—Coalbeds and Deep Saline Aquifers", *J. Air & Waste Manage. Assoc.* 53, 2003, pp. 645–715.
- [2] OPEC, World Oil Outlook 2009, Vienna, Austria, 2009.
- [3] H. Herzog, J. Meldon, A. Hatton, A., "Advanced postcombustion CO<sub>2</sub> capture", prepared for the Clean Air Task Force, Under a grant from the Doris Duke Foundation, 2009.
- [4] C. L. Mariz, "Carbon dioxide recovery: large scale design trends", *J. Can. Petrol. Technol.* Vol. 37, no. 7, 1998.
- [5] E. S. Rubin, E. S., Rao. A. B., "A technical economic and environmental Assessment of amine based CO<sub>2</sub> capture Tech for power plant" GHG control, Annual Technical progress Report, Mellon University, Center for Energy and Environmental studies, 2002.
- [6] W. D. Seider, J. D. Seader and R.L. Daniel, *Process Design Principales*, Wiley, 1999.
- [7] J. Davisa, G. Rochelle, "Thermal degradation of monoethanolamine at stripper conditions", in Proc. 9th. Int. Con. GHG control Tech. Symposium, Washington, USA, 2009.