

# Simulation of a Boost PFC Converter with Electro Magnetic Interference Filter

P. Ram Mohan, M. Vijaya Kumar and O. V. Raghava Reddy

**Abstract**—This paper deals with the simulation of a Boost Power Factor Correction (PFC) Converter with Electro Magnetic Interference (EMI) Filter. The diode rectifier with output capacitor gives poor power factor. The Boost Converter of PFC Circuit is analyzed and then simulated with diode rectifier. The Boost PFC Converter with EMI Filter is simulated for resistive load. The power factor is improved using the proposed converter.

**Keywords**—Boost Converter, Power Factor Correction, Electro Magnetic Interference, Diode Rectifier

## I. INTRODUCTION

THE demand for power, which has increased tremendously over the last few decades, has forced the power engineers to establish reliable network in order to supply quality power to the consumer. Over the years lot of research has been carried out for the supply of quality power to the consumers. This research got a tremendous boost with the strides made in the miniaturization of the electrical industry.

The power electronic devices are very versatile devices capable of delivering power as high as 10KW. These devices are capable of working at frequencies in the range of hundreds of KHz and at the same time the control being only at the gate terminal of the devices, which makes these devices easily controllable.

Various types of single-phase PFC converter circuits have been developed and used to improve the ac current waveform [1-7]. The PFC converter is constructed by use of a boost chopper circuit with a switching device in the dc side of the diode bridge rectifier circuit. A sinusoidal current waveform in phase with the ac line voltage and the constant dc voltage can be obtained from the PFC converter.

EMI problems arise due to the sudden changes in voltage (dv/dt) or current (di/dt) levels in a waveform. In diode rectifier, the line current can be pulse of short duration and the diode recovery current pulse can generate transient voltage

Manuscript received March 20, 2008. This work was supported by ISRO Satellite Center, Bangalore, India.

P. Ram Mohan is with G. Pulla Reddy Engineering College, Kurnool, Andhra Pradesh, India as Assistant Professor. Phone: +919849809510. e-mail: rammohan\_cdp@yahoo.co.in).

M. Vijaya Kumar is with Electrical Engineering Department, JNTU College of Engineering (Autonomous) as Professor and HOD, Anantapur, Andhra Pradesh, India.

O.V. Raghava Reddy is with Indian Space Research Organisation (ISRO) Satellite Center, Bangalore, Karnataka, India as Scientist/ Engineer. e-mail: ovrr@isac.gov.in as Scientist/ Engineer.

spikes in the line inductance. A conductor carrying dv/dt wave acts like an antenna and sensitive signal circuit and appear as noise. The EMI problems create communication line interference with sensitive signal electronic circuits. So, Electro Magnetic Interference Filter (EMI Filter) has to be used at the input of PFC converter to minimize the interference. [8-13].

In this paper, the simulation results of a Boost Power Factor Correction Converter with Electro Magnetic Interference are presented.

## II. ANALYSIS OF BOOST CONVERTER

Fig. 1 shows the boost converter where the output voltage is greater than the input voltage.

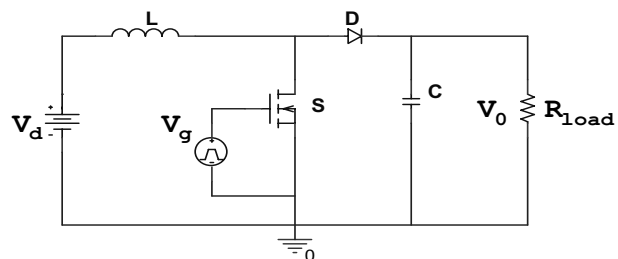

Fig. 1 Boost Converter

Boost converter is also called as step-up converter. A large inductor in series with the source voltage is essential. When the switch is on, the input current flows through the inductor and switch and the inductor stores the energy during this period. When the switch is off, the inductor current cannot die down instantaneously; this current is forced to flow through the diode and the load during this off period. As the current tends to decrease, polarity of the emf induced in  $L_b$  is reversed. As a result, voltage across the load is the sum of supply voltage and inductor voltage and it is greater than the supply voltage.

The voltage impressed across the inductor during on-period is  $V_d$ . During this period, the current rises linearly from a minimum level  $I_1$  to a maximum level  $I_2$ . Therefore the voltage across inductor is,

$$V_L = V_d \quad (1)$$

Also,

$$V_L = L (I_2 - I_1) / T_{on} = L (\Delta I) / T_{on} \quad (2)$$

From (1) and (2),

$$T_{on} = L (\Delta I) / V_d \quad (3)$$

The voltage impressed across the inductor during off period is  $(V_0 - V_d)$  and the current drops linearly from the maximum level  $I_2$  to the minimum level  $I_1$ .

Therefore the voltage across the inductor is,

$$V_L = (V_0 - V_d) \tag{4}$$

$$\text{Also, } V_L = L (I_2 - I_1) / T_{\text{off}} = L (\Delta I) / T_{\text{off}} \tag{5}$$

From (4) and (5),

$$T_{\text{off}} = L (\Delta I) / (V_0 - V_d) \tag{6}$$

From (3),

$$L (\Delta I) = T_{\text{on}} * V_d \tag{7}$$

From (6),

$$L (\Delta I) = T_{\text{off}} * (V_0 - V_d) \tag{8}$$

From (7) and (8)

$$T_{\text{on}} * V_d = T_{\text{off}} * (V_0 - V_d)$$

$$\text{Or } V_0 = (T_{\text{on}} + T_{\text{off}}) * V_d / T_{\text{off}}$$

$$\text{Or } V_0 = T * V_d / T_{\text{off}}$$

$$\text{Or } V_0 = V_d / (1 - \alpha) \tag{9}$$

Where  $\alpha$  = delay angle of the boost converter. As firing angle increases from 0 to 1, the output voltage will be from  $V_d$  to infinity. Hence, the output voltage is boosted.

### III. BOOST POWER FACTOR CORRECTION (PFC) CONVERTER

Fig. 2 shows the Boost Power Factor Correction converter. It comprises of a diode rectifier, boost inductor, switching device, boost diode and boost output capacitor.

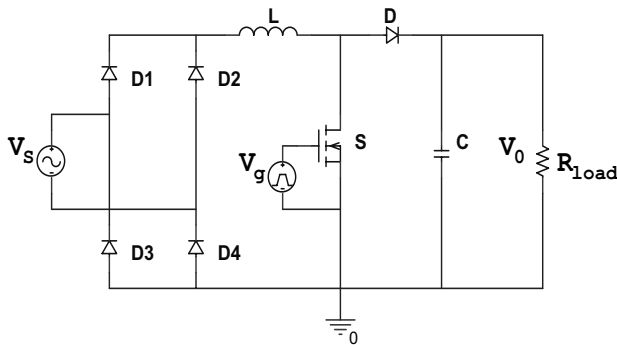

Fig. 2 Boost PFC Converter

The specifications of the proposed Boost PFC converter are

AC input Voltage =  $V_s = 230$  V

DC output Voltage =  $V_0 = 400$  V

Output Power =  $P_{\text{out}} = 500$  W

Switching Frequency =  $F_s = 100$  KHz

Efficiency =  $\eta = 85\%$

The designed values of boost inductor L and output capacitor C are  $L = 1\text{mH}$ ,  $C = 880\mu\text{F}$

### IV. ELECTRO MAGNETIC INTERFERENCE (EMI) FILTER

The Electro Magnetic Interference is transmitted in two forms: radiation and conduction. The switching converters supplied by the power lines generate conducted noise into the power lines that is usually several orders of magnitude higher than the radiated noise into free space. Metal cabinets used for housing power converters reduce the radiated component of the electromagnetic interference.

Conducted noise consists of two categories commonly known as the differential mode and the common mode. The differential mode noise is a current or a voltage measured between the lines of the source that is line-to-line voltage. The common mode noise is a voltage or a current measured between the power lines and ground that is line-to-ground voltage.

An EMI filter is needed to reduce the differential mode and common mode noises in Boost PFC Converter. The filter comprises of inductors and capacitors as shown in figure3.

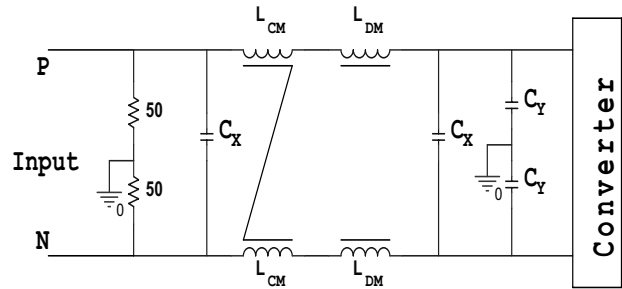

Fig. 3 EMI Filter

In general, for any Boost Power Factor Correction Converters, the corner frequency for CM noise is 28 KHz and the corner frequency for DM noise is 20.5 KHz. The parameters for the EMI Filter i.e. inductance value  $L_{CM}$  for CM noise and inductance value  $L_{DM}$  for DM noise can be calculated as

For CM Noise,

$$f_{RCM} = \frac{1}{2\pi\sqrt{2 * C_Y * L_{CM}}} \tag{10}$$

Here, consider  $C_Y$  as  $0.22\mu\text{F}$ , then

$$L_{CM} = 4.9 \text{ mH}$$

The leakage inductance is in the range of 0.5% to 2% of the  $L_{CM}$  value, then

$$L_{\text{leakage}} = 1\% \text{ of } L_{CM} \tag{11}$$

Therefore,  $L_{\text{leakage}} = 49\mu\text{H}$

For DM Noise,

$$f_{RDM} = \frac{1}{2\pi\sqrt{2 * C_X * L_D}} \tag{12}$$

Here, consider  $C_X$  as  $0.47\mu\text{F}$ , then

$$L_D = 128\mu\text{H}$$

$$L_{DM} = (L_D - L_{\text{leakage}}) / 2 \tag{13}$$

Therefore,  $L_{DM} = 40\mu\text{H}$

### V. RESULTS

The diode rectifier, diode rectifier with output capacitor, Boost PFC Converter with resistive load and Boost PFC Converter with EMI Filter with resistive load circuits are simulated using ORCAD PSPICE Software of Version 9.2.

The diode rectifier with resistive load is simulated and the simulation results are shown in fig.4. The simulated results of input voltage and input current waveforms of diode rectifier with output capacitor are shown in fig.5. From this figure, it can be seen that the power factor is low since the angle between input voltage and current is high.

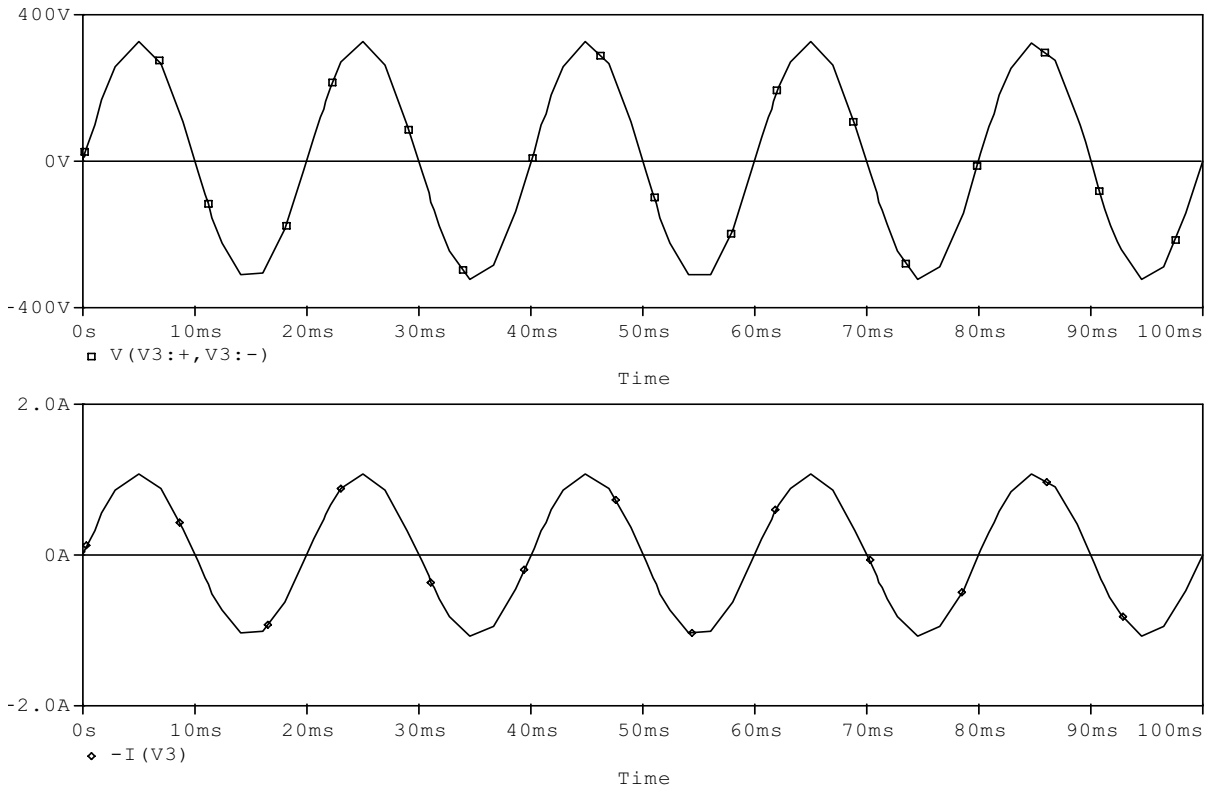

Fig. 4 Input voltage and input current waveforms of diode rectifier

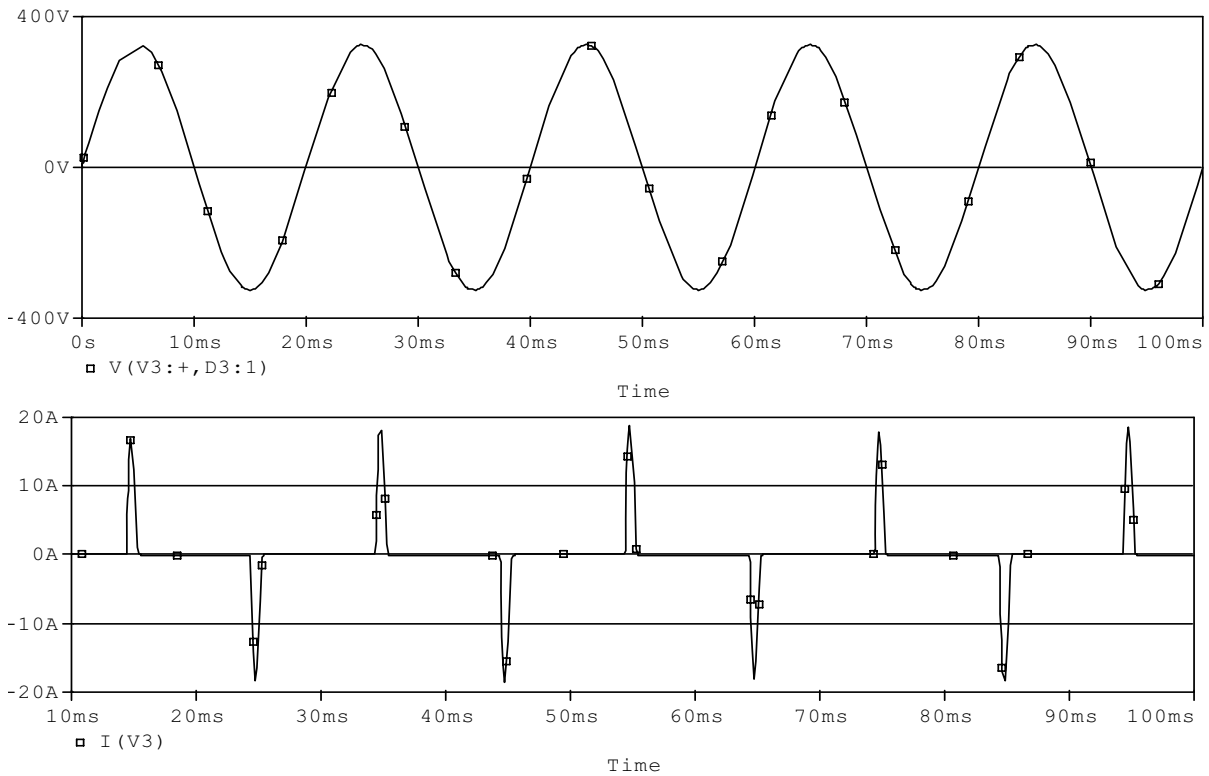

Fig. 5 Input voltage and input current waveforms of diode rectifier with output capacitor

The simulated waveforms of input voltage and input current are shown in fig. 6. From this figure, it can be seen that the input voltage and current are in phase and the input current has some harmonics and noise. These harmonics and noise can be reduced by using EMI Filter connected at the input side of Boost PFC Converter

Boost PFC Converter with EMI Filter with resistive load are shown in fig. 7. The output voltage and output current of Boost PFC Converter with EMI Filter with resistive load are shown in fig. 8.

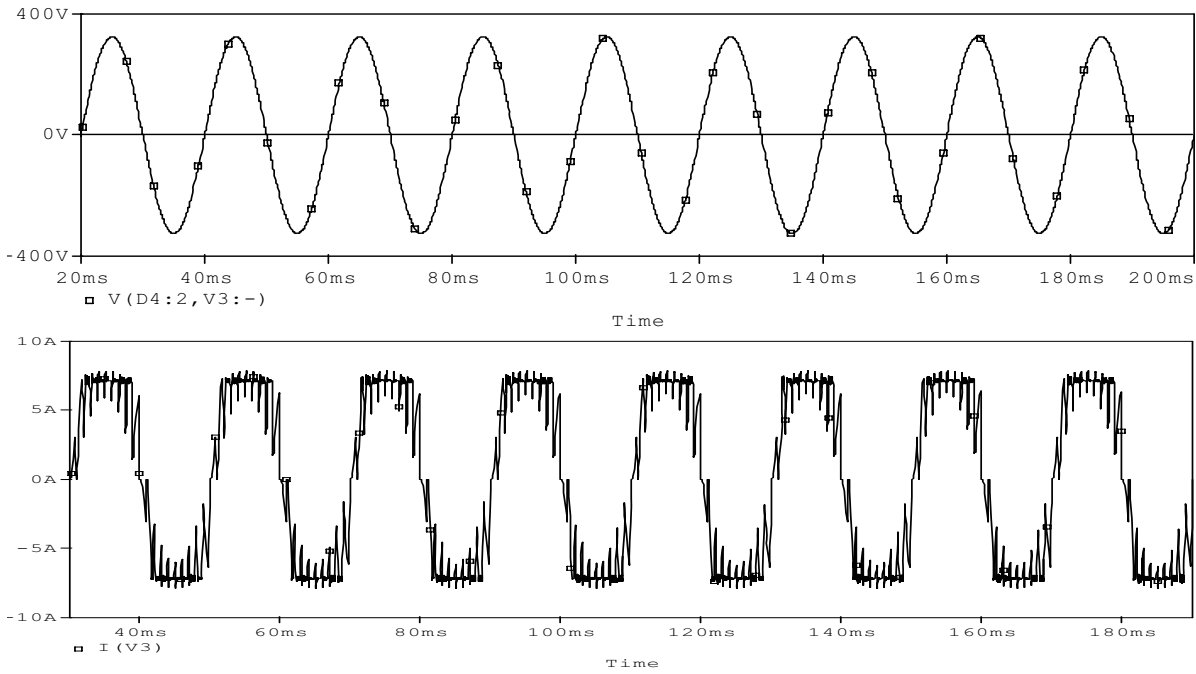

Fig. 6 Input voltage and input current waveforms of Boost PFC Converter with R Load

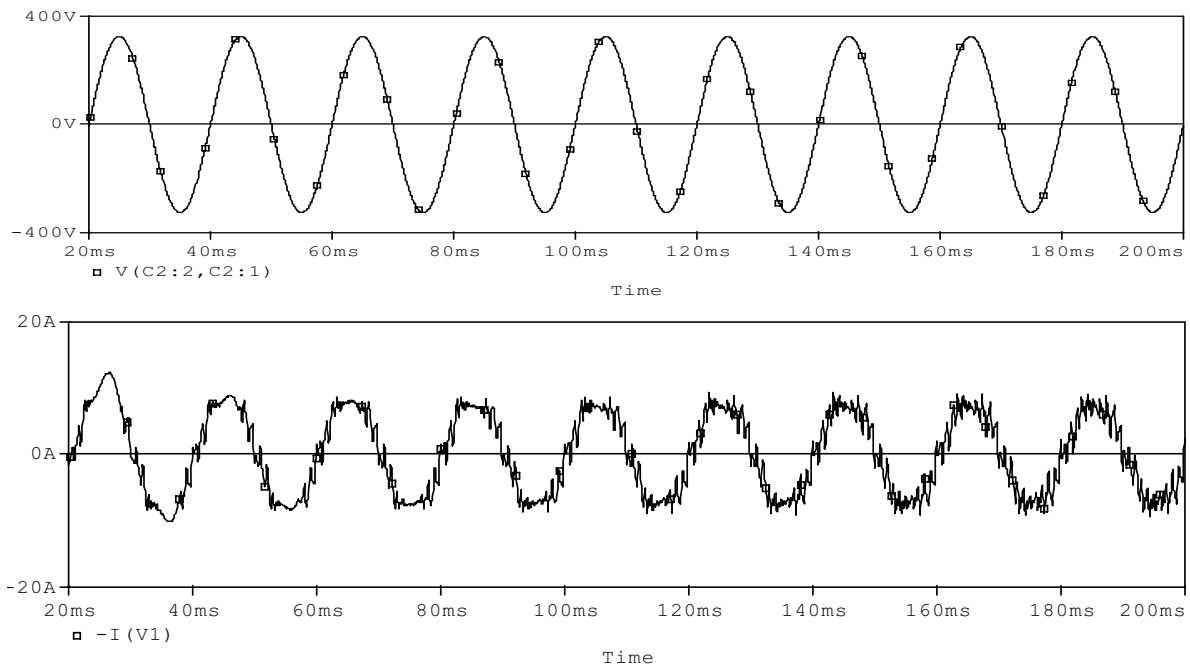
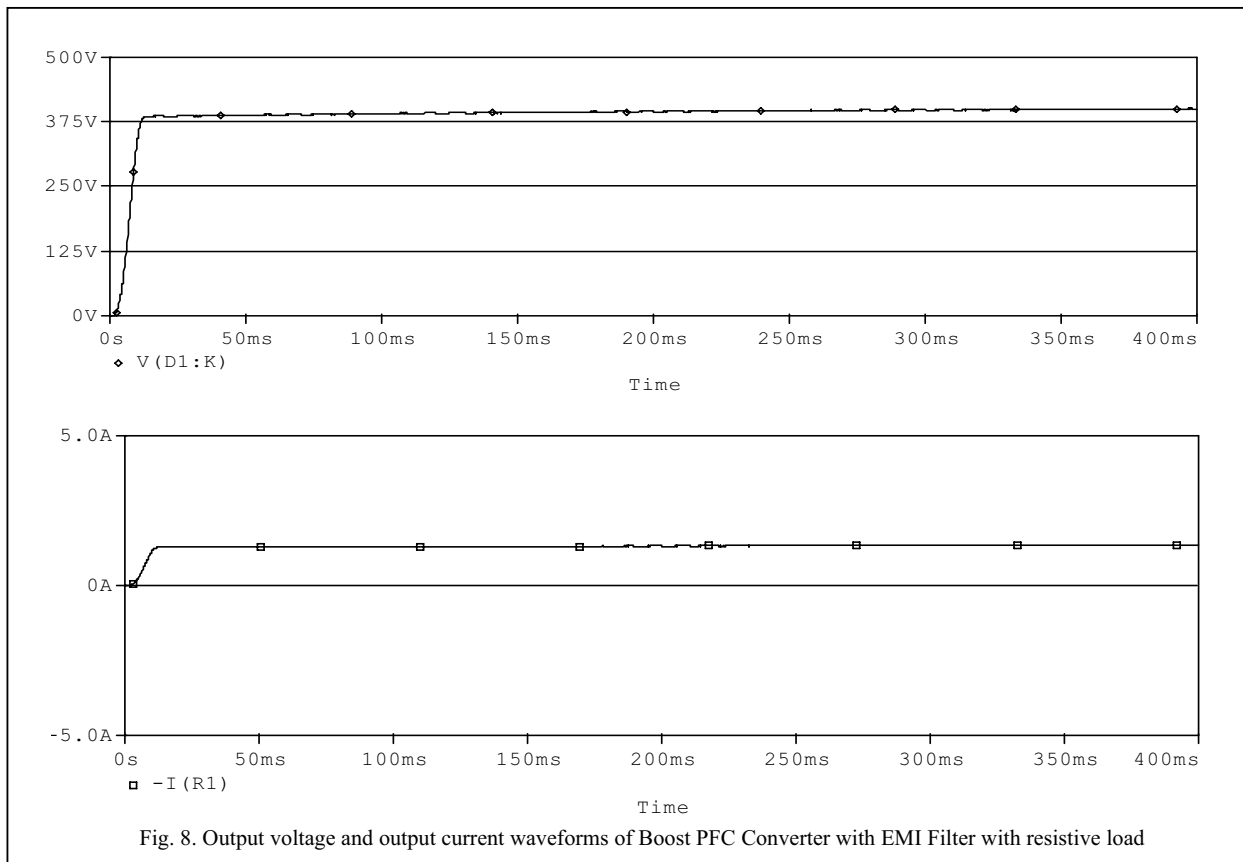

Fig. 7 Input voltage and input current waveforms of Boost PFC Converter with EMI Filter with resistive load



## VI. CONCLUSION

The diode rectifier with output capacitor is simulated. Boost Converter is analyzed and simulated with diode rectifier. The Boost Power Factor Correction (PFC) Converter is simulated with and without Electro Magnetic Interference (EMI) Filter for resistive load. The simulation results are presented in this paper. The power factor is improved using the proposed converter.

## ACKNOWLEDGMENT

The authors are thankful to the scientists of Indian Space Research Organization (ISRO) Satellite Centre, Bangalore, INDIA for their constant encouragement and help in doing in this research work.

## REFERENCES

- [1] Guichao Hua and F C Lee, "Soft switching techniques in PWM converters", in *Proceedings of IEEE-IECON Conference IECON*, 1993, pp.637-643.
- [2] M.M. Jovanovic, "A technique for reducing rectifier reverse recovery related losses in high voltage, high power boost converters", in *Proceedings of IEEE - APEC Conference APEC*, 1997, pp.1000-1007.
- [3] T. Ohnishi, "Binary controlled single phase PFC rectifier", *Proceedings of IEEE - IECON Conference IECON*, 2000, pp.2666-2671.
- [4] T. Ohnishi and M. Hojo, "Single phase PFC converter constructed by ac line voltage waveform detection", *Proceedings of SPC Conference SPC*, 2002, pp.7-11.
- [5] S. Busquets-Monge and G. Soremekun, "Design of a boost power factor correction converter using genetic algorithms", *Proceedings of IEEE - APEC Conference APEC*, 2002, pp.1177-1182.
- [6] Y.Jang and M.M.Jovanovic, "A new soft switched high power factor boost converter with IGBTs", *IEEE Transactions on Power Electronics*, July 2002, Vol.17, pp.469-476.
- [7] Wanfeng Zhang, Guang Feng, Yan-Fei Liu and Bin wu, "A digital Power Factor Correction Control Strategy optimized for DSP", *IEEE Transaction on Power Electronics*, November 2004, Vol.19.
- [8] David.A.Williams, "A Tutorial on EMI Characterization of Switching Regulators", *Proceedings of IEEE - APEC Conference APEC*, 1996, pp. 333-339.
- [9] W. Zhang, M.T. Zhang, F.C. Lee, J. Roudet and E. Clavel, "Conducted EMI analysis of a boost PFC circuit", *Proceedings of IEEE - APEC Conference APEC*, 1997, pp. 223 -229.
- [10] J.C. Crebier, M. Brunello and J.P. Ferrieux, "A new method for EMI study in boost derived PFC rectifiers", *Proceedings of IEEE - PESC Conference PESC*, 1999, pp. 855 -860.
- [11] X. Wu; M.H. Pong, Z.Y. Lu and Z.M. Qian, "Novel boost PFC with low common mode EMI: Modeling and Design", *Proceedings of IEEE - APEC Conference APEC*, 2000, pp. 178 -181.
- [12] S. Qu and D. Chen, "Mixed-mode EMI noise and its implications to filter design in offline switching power supplies", *IEEE Transactions on Power Electronics*, Vol. 17, July 2002, pp. 502-507.
- [13] Liyu Yang, "Modeling and characterization of a PFC converter in the medium and high frequency ranges for predicting the conducted EMI", M.S. thesis, Virginia Polytechnic Institute and State University, 2003.