

Shunt Power Active Filter Control under Non Ideal Voltages Conditions

H. Abaali, M. T. Lamchich, and M. Raoufi

Abstract—In this paper, we propose the Modified Synchronous Detection (*MSD*) Method for determining the reference compensating currents of the shunt active power filter under non sinusoidal voltages conditions. For controlling the inverter switching we used the *PI* regulator. The numerical simulation results, using Power System Blockset Toolbox *PSB* of Matlab, from a complete structure, are presented and discussed.

Keywords—Distorted, harmonic, Modified Synchronous Detection Method, *PI* regulator, Shunt Active Power Filter, unbalanced.

I. INTRODUCTION

THE increased severity of harmonic pollution in power networks drawn by power electronic devices, has attracted the attention of power electronics and power system engineers to develop dynamic and adjustable solutions to the power quality problems. A solution is known as active filters with several types of active filter topologies [1]-[5]. This paper will be restricted to the shunt active power filter which is generally used to compensate the reactive power and eliminate the harmonic currents produced on the load side from the grid current, by injecting compensating currents [2], [6], [7], [12] and [13].

For determining the reference current a number of methods are emphasized in the literature [1]-[4], [6]. This paper focuses on one time domain technique known as Synchronous Detection Method (*SD*). The major limitation of the *SD* method is its spectral performances which are deteriorated under distorted voltages conditions. We propose a Modified Synchronous Detection (*MSD*) algorithm consisting of the association of the traditional *SD* method with a fundamental positive sequence voltage detector (*PSVD*) in the aim to improve the compensation performances under all voltages conditions. We used the proportional and integrator (*PI*) regulator for controlling the inverter switching.

Manuscript received June 7, 2005.

H. Abaali Laboratory of Electronics and Instrumentation, Cadi Ayyad University, Faculty of Sciences Semailia, BP 2390, Marrakech 40000, Morocco (e-mail: h.abaali@ucam.ac.ma, phone: 212-44 43 46 49, fax : 212-44 43 74 10).

M. T. Lamchich Laboratory of Electronics and Instrumentation, Cadi Ayyad University, Faculty of Sciences Semailia, BP 2390, Marrakech 40000, Morocco (e-mail: lamchich@ucam.ac.ma).

M. Raoufi Laboratory of Electronics and Instrumentation, Cadi Ayyad University, Faculty of Sciences Semailia, BP 2390, Marrakech 40000, Morocco (e-mail: raoufi@ucam.ac.ma).

The shunt active filter performance for the investigated identification and regulated methods are evaluated quantitatively by calculating the Individual and Total Harmonic Distortion (*THD*) of the line current using the simulation results under ideal, unbalanced and distorted mains voltages conditions with a load consisting of three phase diodes based rectifier.

II. GENERAL STRUCTURE

The main circuit of the shunt power active filter *PAF* control is shown in Fig. 1.

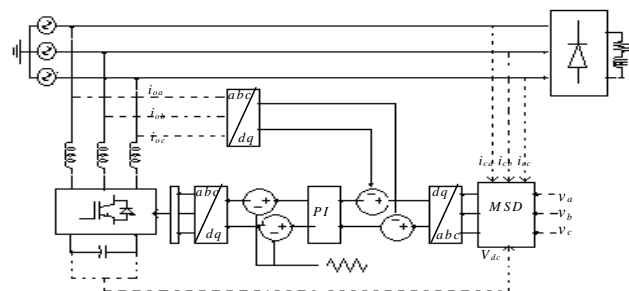

Fig. 1 General structure of the SAPF control

This circuit is composed by

- Three wires of the power network (220V, 50Hz),
- Three phase diodes based rectifier ($R, L = (150\Omega, 1mH)$);
- Modified Synchronous Detection Method (*MSD*) block,
- Corrector block based on the *PI* regulator,
- *SAPF* consisting of a voltage source inverter (*VSI*) with a capacitor in its *dc* side,
- First order output filter.

III. SYNCHRONOUS DETECTION METHOD

The Synchronous Detection Method [1] is introduced in order to calculate instantaneously the reference currents. In this algorithm, the three-phase mains currents are assumed to be balanced after compensation, thus:

$$I_{ma} = I_{mb} = I_{mc} \quad (1)$$

where I_{ma} , I_{mb} and I_{mc} are the amplitudes of the three-phase mains currents after compensation. The real power consumed by the load can be expressed as:

$$P = [v_a v_b v_c] \begin{bmatrix} i_{ca} \\ i_{cb} \\ i_{cc} \end{bmatrix} \quad (2)$$

v_k and i_{ck} where $k=(a,b,c)$ are respectively the mains voltages source and load currents.

The diagram of *MSD* method, is given in Fig. 2

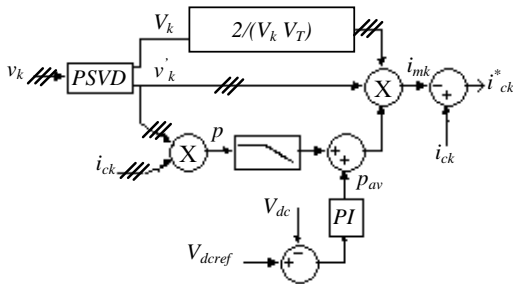

Fig. 2 Current identification block diagram (*MSD*)

The low-pass filter is used to extract the average value \bar{P} of the real power P , which is added to the p_{av} corresponding to the control of dc voltage. The real power is then split into the three-phases of the mains supply:

$$P_k = (\bar{P} + p_{av}) V_k / V_T \quad (3)$$

where V_k are the amplitude of each mains voltages, and $V_T = \sum_K V_K$. The desired mains currents can be calculated as:

$$i_{mk} = \frac{2v_k}{V_k^2} P_k, \quad (4)$$

The reference currents are given by

$$i_{ck}^* = i_{ck} - i_{mk} \quad (5)$$

IV. POSITIVE SEQUENCE VOLTAGE DETECTOR (*PSVD*)

As described below, from simulation results, the classical *SD* theory is not effective under distorted mains voltages conditions. To obtain good performances under non sinusoidal voltages conditions, we inserted a fundamental positive sequence detector block [1], [12], which uses a *PLL* (Phase-Locked-Loop) circuit locked to the fundamental frequency of the system voltages. The *PLL* allows control of estimated phase angle $\hat{\theta}$ with respect to the angle θ of mains voltages when $\Delta\theta = (\theta - \hat{\theta})$ is equal zero. In this case $v_d^* = 0$ and v_q gives the amplitude of the fundamental positive sequence voltage. The *PSVD* diagram is given in Fig. 3.

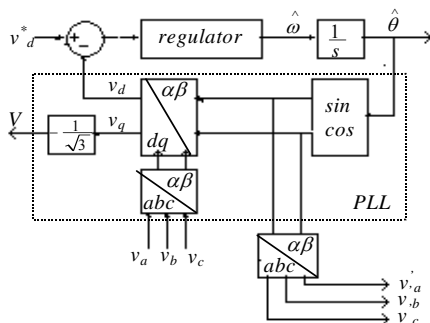

Fig. 3 Fundamental positive sequence voltage detector block

V. SHUNT ACTIVE FILTER CONTROL

Two control loops are studied, the inner loop responsible for the ac current control and the outer loop responsible of dc voltage control with the consideration that the power is flowing from the capacitor source voltage to the grid.

A. Current Technique Control

The output currents of the inverter must track the reference currents produced by the current identification block. Consequently a regulation block is required and must be designed. Different techniques have been developed [3], [4]. In this paper, the inverter is controlled using a *PI* regulator with a *PWM* modulator [8]–[11], the nominal switching frequency f_s is equal to 10 kHz.

The control circuit topology is shown in Fig. 4.

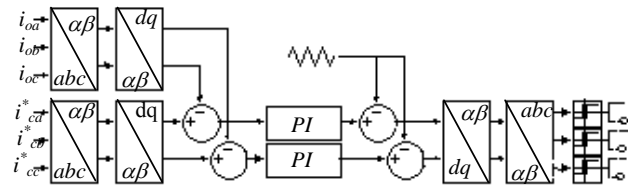

Fig. 4 *PI* inverter controller block

i_{ok} and i_{ck}^* $k=(a,b,c)$ are respectively the active power filter output currents and reference currents.

B. dc Voltage Control

The closed-loop transfer function of dc voltage regulation (Fig. 5) is given by

$$\frac{V_{dc}}{V_{dcref}} = \frac{k_p}{C} \frac{s + k_i / k_p}{s^2 + (k_p / C)s + (k_i / C)} \quad (6)$$

k_p and k_i are respectively the proportional and integrator gains of the *PI* controller. The design of the *PI* controller is realized by identifying (6) to a prototype of second order system given by (7). The variable values considered are damping ratio $\zeta = 0.7$ and a natural undamped frequency $\omega_n = \omega / 5$ (ω : angular frequency).

$$\frac{V_{dc}}{V_{dcref}} = 2\zeta\omega_n \frac{s + \omega_n / 2\zeta}{s^2 + (2\zeta\omega_n)s + \omega_n^2} \quad (7)$$

where k_p and k_i are computed from the relations:

$$k_p = 2\zeta\omega_n C \quad \text{and} \quad k_i = \omega_n^2 C$$

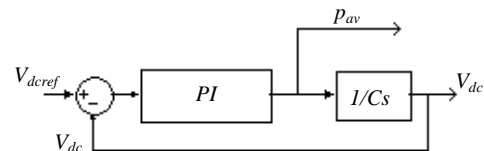

Fig. 5 dc Voltage control block

VI. OUTPUT FILTER

In this work the first order passive output filter is used to connect the active power filter to the Point of Common Connection (PCC). Its inductors L transform the voltage source inverter (VSI) with its capacitor in a current source and also smooth the inverter currents (i_o .)

The good design of this output filter depends on the compromise to find between the dynamics and the effectiveness of the parallel active filter. The maximal undulation value of the inverter current ($\Delta I_{o\max}$) is given by

$$\Delta I_{o\max} = \frac{V_{dc}}{12 \cdot f_s \cdot L} \tag{8}$$

One deduces the expression from it allowing to calculate the inductors L , according to the relative undulation of the current i_o ($\delta I_o (\%) = 100 \cdot \Delta I_o / I_{o\text{eff}}$):

$$L = \frac{100 \cdot V_{dc}}{12 \cdot f_s \cdot \delta I_o (\%) \cdot I_{o\text{eff}}} \tag{9}$$

Also, It is necessary that its voltage drop ($V_L = L \omega I_{o\text{eff}}$) must be lower than 20% of the voltage source.

VII. SIMULATION RESULTS

The purpose of the simulation is to show the effectiveness of the shunt active power filter in reducing the harmonic pollution produced on the load side under non sinusoidal mains voltages conditions, using MSD algorithm for references currents identification.

A. First Case: Ideal Voltages Source Conditions

The three phase voltages source are balanced and do not contain harmonic components Fig. 6 (a). Fig. 6 (b) shows the line current and its spectrum before compensation. The line current and its spectrum after compensation is represented in Fig. 6 (c).

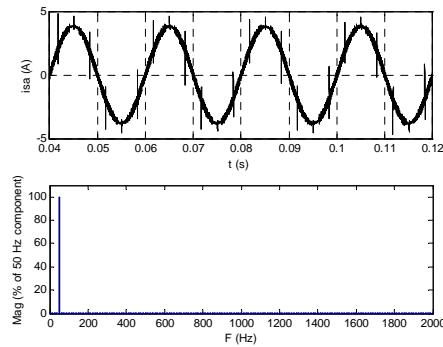
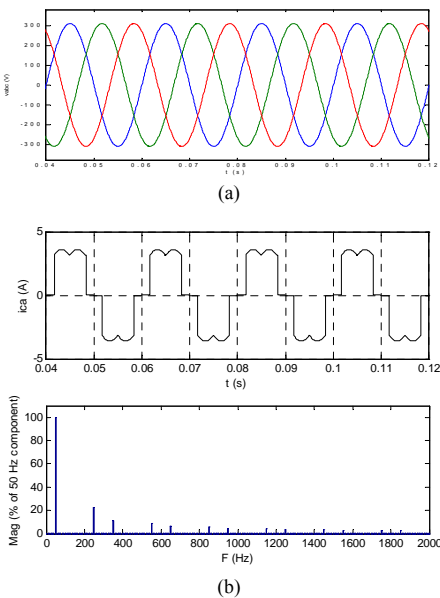

Fig. 6

(a) Ideal voltages source, (b) line current and its spectrum before compensation, (c) line current and its spectrum after compensation using SD and MSD

Table I illustrates the individual amplitude of low-order harmonics in the supply current as a percentage of the fundamental component compared to individual harmonics given in IEC 1000-3-4.

h	I _h /I ₁ (%) Before Compensation (BC)	I _h /I ₁ (%) After Compensation (AC)	IEC 1000-3-4 I _h /I ₁ (%)
5	22.6	0.3	9.5
7	11.3	0.3	6.5
11	9.0	0.3	3.1
13	6.5	0.3	2.0
17	5.7	0.4	1.2
19	4.5	0.3	1.1

The line current Total Harmonic Distortion (THD_i) before compensation is 29.6% which is reduced to 1.0% after compensation using SD and MSD.

B. Second Case: Unbalanced Voltages Source Conditions

The three phase voltages source are unbalanced Fig. 7 (a), but do not contain harmonic components, their expressions are given in (10). Fig. 7 (b) and 7 (c) show the line current and its spectrum respectively before and after compensation using SD method. The line current and its spectrum after compensation using MSD method is represented in Fig. 7 (d).

$$\begin{aligned} v_a(t) &= V_1 \sin \omega t + 0.13 V_1 \sin \omega t \\ v_b(t) &= V_1 \sin(\omega t - \frac{2\pi}{3}) + 0.13 V_1 \sin(\omega t + \frac{2\pi}{3}) \\ v_c(t) &= V_1 \sin(\omega t + \frac{2\pi}{3}) + 0.13 V_1 \sin(\omega t - \frac{2\pi}{3}) \end{aligned} \tag{10}$$

where $V_1 = \sqrt{2} \cdot 220$

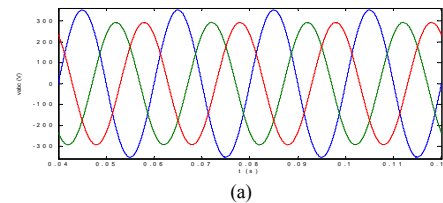

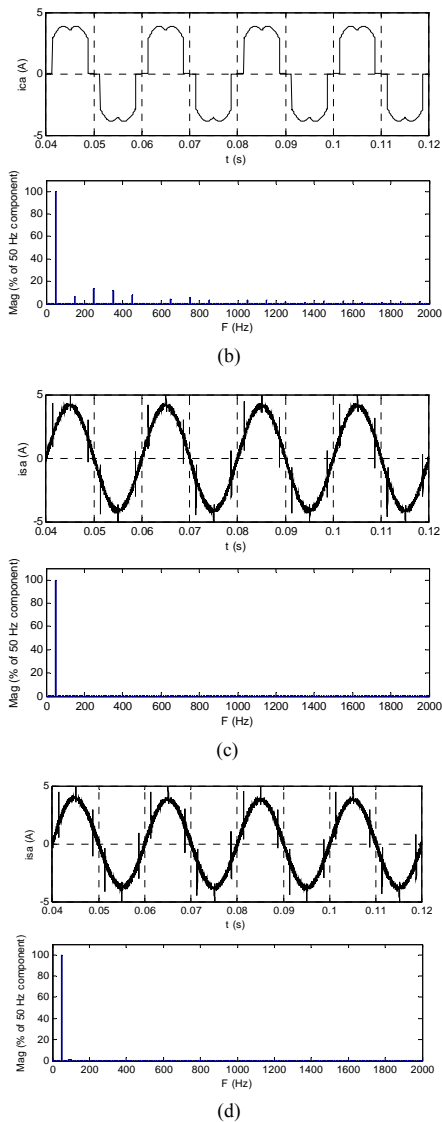

Fig. 7 (a) Unbalanced voltages source and (b) line current and its spectrum before compensation. (c) and (d): line current and its spectrum after compensation using SD and MSD respectively

The harmonic contents repartition before and after compensation using the two methods, under unbalanced voltages conditions, is resumed in Table II.

TABLE II
HARMONIC CONTENTS OF THE SUPPLY CURRENTS (UNBALANCED CONDITIONS)

h	I_h/I_1 (%) BC	I_h/I_1 (%) AC	
		SD	MSD
3	6.8	0.8	0.5
5	13.4	0.5	0.5
7	11.5	0.3	0.4
9	7.9	0.3	0.3
11	0.1	0.4	0.4
13	4.3	0.2	0.2
15	5.9	0.4	0.4
17	3.2	0.3	0.4
19	0.3	0.1	0.1

Table II shows that significant levels of triplens harmonic currents are added before compensation under unbalanced voltages conditions, and illustrates also the individual amplitude of low-order harmonics in the supply currents as a percentage of the fundamental components.

Line current THD_i is 23.2% witch is reduced to 1.6% after compensation using SD and MSD.

C. Third Case: Distorted Voltages Source Conditions

The three phase voltages source are balanced Fig. 8 (a), but contain the 5th and 7th harmonic components, their expressions are given in (11). The voltage Total Harmonic Distortion (THD_v) of the shunt active filter in the Point of Common Connection (PCC) is 24.6%. Fig. 8 (b) and 8 (c) show the line current and its spectrum respectively before and after compensation using the SD method. The line current and its spectrum after compensation using MSD is represented in Fig. 8 (d).

$$\begin{aligned}
 v_a(t) &= V_1 \sin \omega t - V_5 \sin 5 \omega t + V_7 \sin 7 \omega t \\
 v_b(t) &= V_1 \sin \left(\omega t - \frac{2\pi}{3} \right) - V_5 \sin \left(5 \omega t + \frac{2\pi}{3} \right) + V_7 \sin \left(7 \omega t - \frac{2\pi}{3} \right) \\
 v_c(t) &= V_1 \sin \left(\omega t + \frac{2\pi}{3} \right) - V_5 \sin \left(5 \omega t - \frac{2\pi}{3} \right) + V_7 \sin \left(7 \omega t + \frac{2\pi}{3} \right)
 \end{aligned}
 \tag{11}$$

where $V_5 = V_1 / 5$ and $V_7 = V_1 / 7$

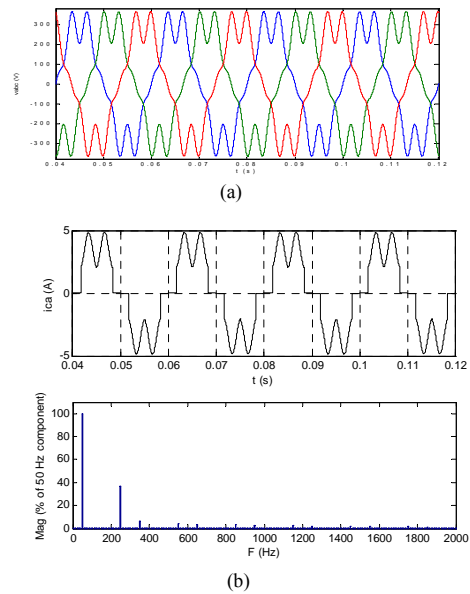

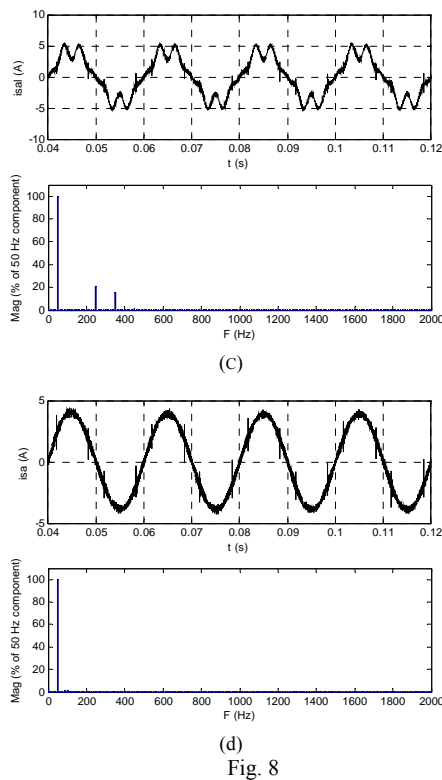

Fig. 8
(a) Distorted voltages source. (b) line current and its spectrum before compensation. (c) and (d): line current and its spectrum after compensation using *SD* and *MSD* respectively

The harmonic contents repartition before and after compensation using the two methods, under distorted voltages conditions, is resumed in Table III.

TABLE III
HARMONIC CONTENTS OF THE SUPPLY CURRENTS (DISTORTED VOLTAGES CONDITIONS)

h	I_h/I_1 (%)	
	BC	SD
5	7.1	20.9
7	6.3	15.6
11	4.6	0.4
13	3.5	0.8
17	3.4	0.1
19	2.7	0.1

Line current THD_i is 38.6% which is reduced to 26.1% using *SD* and to 1.0% using *MSD*.

Table III shows, the individual amplitude of low-order harmonics in the supply currents as a percentage of the fundamental components under distorted voltages conditions. We can conclude that the 5th and 7th harmonic currents components are amplified after compensation using a classical *SD*, however all currents harmonic are compensated using *MSD*.

The synthesis of all these results is resumed in Table IV.

TABLE IV
HARMONIC ISOLATION SUMMARY

Identification methods	SD		MSD
	BC	AC	
Ideal case	BC	29.6	1.0
	AC	1.0	
Unbalanced case	BC	23.2	1.6
	AC	1.6	
Distorted case	BC	38.6	1.0
	AC	26.1	
Amplification of harmonic currents	Yes		No

Table IV shows that the *SD* method is an acceptable solution, for reference currents calculation, under ideal and unbalanced voltages conditions; however it is worse under distorted voltages source conditions, because of the amplification of the harmonic currents after compensation. The *MSD* method, proposed in this paper, is in addition more adapted for the case of distorted voltages source.

VIII. CONCLUSION

This paper has described the control of shunt active power filter using a *PI* regulation and Synchronous Detection algorithm (*SD*) and its combination with the positive sequence voltage detector block (*PSVD*) to maintain sinusoidal source currents when the source supplies a nonlinear load under distorted and unbalanced mains voltages conditions.

Compared to standards (*IEC 1000-3-4*) the presented results have proven good performances and verify the feasibility of the modified detection algorithm. This method is most effective for all source voltages conditions. These results highlight also the major problem of the standard *SD* algorithm which is the amplification of the undesirable harmonic currents in the line current under distorted voltages conditions. Moreover, it provides acceptable results without the need of *PSVD*, under ideal and unbalanced voltages conditions.

Investigations on the same problem with the neutral conductor in unbalanced loads configuration with reactive power compensation are in progress.

REFERENCES

- [1] H. -L. Jou, "Performance comparison of the three-phase active power filter algorithm," *IEE Proc. Gen. Trans. Distrib.*, Vol. 142, No.6, 1995.
- [2] A. Allali, "Contribution à l'étude des compensateurs actifs des réseaux électriques basse tension," Thèse Université Louis Pasteur Strasbourg, Ecole Doctorale Sciences pour l'Ingénieur, 12 Sept. 2002.
- [3] B. Singh, K. Al-Haddad and A. Chandra, "A review of active filters for power quality improvement," In: *IEEE Transactions on Industrial Electronics*. Vol. 46. No. 5, pp. 960-971, October 1999.
- [4] C. Brandao, J. Antonio and M. Lima: Edison Roberto Cabral da Silva, "A revision of the state of the art in active filters," In: *5th Power Electronics Conferences*, pp 857-862, Brazil, 19-23. Sept. 1999.
- [5] M. Aredes, "Active power line conditioners," doctor engineer approved thesis, Berlin 1996 D83.
- [6] Vedat M. Karlı, Mehmet Tümay and Berrin Süslüoğlu, "An evaluation of time domain techniques for compensating currents of shunt active power filters," *International Conference on Electrical and Electronics Engineering Bursa, Turkey*, Dec. 2003.
- [7] H. Abali, M. T. Lamchich and M. Raoufi, "Modified synchronous detection method for shunt active filter reference currents identification under non sinusoidal voltages conditions," *Institut des Nouvelles*

Technologies de l'Information et de la Communication 1 Algésiras -
Tanger, 14 – 17 Dec. 2004.

- [8] S.-Y. Lee, Y.-M. Chae, J.-S. Cho, G.-H. Choe and H.-S. Mok E D.-H. Jang, "A new control strategy for instantaneous voltage compensator using 3-phase pwm inverter," IEEE, PESC 98, Fukuoka, Japão, May 1998, pp. 248-254.
- [9] J. Nastran, R. Cajhen, M. Seliger and P. Jereb, "Active power filter for nonlinear ac loads," IEEE - Trans. on Power Electronics, Vol. 9, No. 1, pp. 92-96, Jan. 1994.
- [10] J.W. Dixon, L. Moran and R.R. Wallace, "A three-phase active power filter operating with fixed switching frequency for reactive power and current harmonic compensation," IEEE Trans. on Industrial Electronics, Vol.-42, No 4, pp. 402-408, Aug. 1995.
- [11] P. Verdelho and G. D. Marques, "An active power filter and unbalanced current compensator control circuit," VI European Conference on Power Electronics and Applications, pp. 1.929-1.934, Sevilla, Spain, Sept. 1995.
- [12] A. Chaghi, A. Guettafi and A. Benououdijit, "Shunt active filter compensating current harmonics under disturbed voltage network," Journal of Electrical Engineering, No. 1, Vol. 4, 2004.
- [13] S. D. Round and D. M. E. Ingram "An evaluation of techniques for determining active filter compensating currents in unbalanced systems," Proc. European Conf. on Power Electronics and Applications, vol. 4, pp. 767-772, Trondheim, 1997.