

Seawater Desalination for Production of Highly Pure Water Using a Hydrophobic PTFE Membrane and Direct Contact Membrane Distillation (DCMD)

Ahmad Kayvani Fard, Yehia Manawi

Abstract—Qatar's primary source of fresh water is through seawater desalination. Amongst the major processes that are commercially available on the market, the most common large scale techniques are Multi-Stage Flash distillation (MSF), Multi Effect distillation (MED), and Reverse Osmosis (RO). Although commonly used, these three processes are highly expensive down to high energy input requirements and high operating costs allied with maintenance and stress induced on the systems in harsh alkaline media. Beside that cost, environmental footprint of these desalination techniques are significant; from damaging marine eco-system, to huge land use, to discharge of tons of GHG and huge carbon footprint.

Other less energy consuming techniques based on membrane separation are being sought to reduce both the carbon footprint and operating costs is membrane distillation (MD).

Emerged in 1960s, MD is an alternative technology for water desalination attracting more attention since 1980s. MD process involves the evaporation of a hot feed, typically below boiling point of brine at standard conditions, by creating a water vapor pressure difference across the porous, hydrophobic membrane. Main advantages of MD compared to other commercially available technologies (MSF and MED) and specially RO are reduction of membrane and module stress due to absence of trans-membrane pressure, less impact of contaminant fouling on distillate due to transfer of only water vapor, utilization of low grade or waste heat from oil and gas industries to heat up the feed up to required temperature difference across the membrane, superior water quality, and relatively lower capital and operating cost.

To achieve the objective of this study, state of the art flat-sheet cross-flow DCMD bench scale unit was designed, commissioned, and tested. The objective of this study is to analyze the characteristics and morphology of the membrane suitable for DCMD through SEM imaging and contact angle measurement and to study the water quality of distillate produced by DCMD bench scale unit. Comparison with available literature data is undertaken where appropriate and laboratory data is used to compare a DCMD distillate quality with that of other desalination techniques and standards.

Membrane SEM analysis showed that the PTFE membrane used for the study has contact angle of 127° with highly porous surface supported with less porous and bigger pore size PP membrane. Study on the effect of feed solution (salinity) and temperature on water quality of distillate produced from ICP and IC analysis showed that with any salinity and different feed temperature (up to 70°C) the electric conductivity of distillate is less than 5 μ S/cm with 99.99% salt rejection and proved to be feasible and effective process capable of consistently producing high quality distillate from very high feed salinity solution (i.e. 100000 mg/L TDS) even with substantial quality difference compared to other desalination methods such as RO and MSF.

Keywords—Membrane Distillation, Waste Heat, Seawater Desalination, Membrane, Freshwater, Direct Contact Membrane Distillation.

I. INTRODUCTION

WATER is a main component in determining the value of our lives. Today, people are concerned about the quality of the water they drink. Although water covers more than 70% of the Earth, only 1% of the Earth's water is available as a source of drinking for human being. Yet, societies continue to contaminate this precious resource by different means. Nowadays, treatment of drinking water is no more considered as a luxury practice but, it is an essential requirement for people to survive! Consumers are taking matters into their own hands and are now determining the quality of the water they and their families will drink by installing a drinking water system that will give them clean, refreshing, and healthier water.

The Middle East is one of the poorest regions in terms of water resources in the world. Freshwater resources available in the region are less than 1% of the total available global freshwater. However, the region is home of 6% of the world's total population and one of the highest population growth rate region in the world. There are two challenges faced in terms of water resource in the Middle East. Firstly, natural water resources such as lakes, rivers, and springs are close to zero in this region, and secondly, water consumption rates in the Middle East and specifically in Gulf Cooperation Council (GCC) countries which is the biggest part of the Middle East region are one of the highest in the world. Natural Water resources in the GCC countries are generally limited due to the low average annual rainfall and high evaporation. Main water resource in this region is coming from desalination plants to substitute for water deficiency.

TABLE I
GCC POPULATION AND WATER RESOURCE[2]

Country	Area (km ² x10 ⁶)	Pop. (x10 ⁶)	Rain (BCM)	Evap. (mm)	Cons. (L/d)
KSA	2.15	28.5	158.5	4000	252
Kuwait	0.017	3	2.3	2500	476
Bahrain	0.00069	0.55	0.40	1800	455
Qatar	0.016	1.4	0.47	2350	407
UAE	0.07	2.44	6.72	4000	770
Oman	0.3	2.52	37.60	2400	146

In a recent study by Maplecroft [1], the GCC countries: Bahrain, Qatar, Kuwait, and Saudi Arabia were rated as the

Ahmad Kayvani Fard and Yehia Manawi are with the Qatar Energy and Environment Research Institute, Doha, Qatar (phone: +974 4454 1540; fax: +974 4454 1528; e-mail: afard@qf.org.qa, ymanawi@qf.org.qa).

world's most water-stressed countries, with the least available water per capita. Table I shows some statistics of 6 GCC countries in term of water demand and consumption.

One of the plans to fulfill current and future demand of water in GCC countries is to build desalination plants. From all the desalination plants in the world, 50% of them are present in the GCC region. Increasing demand of water as a result of population growth and changing life style, capacity of desalination plants are in rapid growth and expected to increase by 35% in GCC countries and 25% globally [3].

GCC countries use different desalination technologies (MSF, MED and RO) to satisfying the demand and drought condition. Most of desalination plants run with natural gas as a fuel which makes it more efficient, less cost and more environmentally safe than using the petroleum. Although natural gas has better efficiency compared to petroleum fuel, but both release huge amounts of GHG gases such as CO₂ and NO_x which has some impact on the environment that might accelerate the increase in temperature and decrease the precipitation. Table II shows number of desalination plants in each GCC country and their capacity accordingly.

TABLE II
EXISTING AND FUTURE PLANNED DESALINATION PLANTS IN GCC COUNTRIES [4]

Technology	UAE	Bahrain	KSA	Oman	Qatar	Kuwait
MSF	20.0	1.0	20.0	3.0	6.0	7.0
RO	25.0	3.0	79.0	45.0	2.0	1.0
MED	9.0	2.0	9.0	0	2.0	0
VC	0	1.0	0	0	0.0	0
ED	0	0	0	0	0	0
RO+MSF	2.0	1.0	0	1.0	0	0
Total	55.0	7.0	108.0	49.0	10.0	8.0

According to the latest report from the 24th IDA Worldwide Desalting Plant Inventory the installed capacity for desalination of seawater approached 77.4 million m³/day by the end of 2012 which is distributed among 16000 desalination plants worldwide. 77% of these plants are located in Middle East and about two thirds of this water is produced by thermal processes whereas membrane desalination is the predominating process outside the region. Six percent of all plants are located in the Asia-Pacific region, 7% in the Americas, and the rest 10% in Europe [5].

In state of Qatar, potable water demand for drinking purposes is increasing every year by 10% which can lead to environmental issues. As shown in Fig. 1 current and forecasted demand of water in Qatar is shown. If only an MSF plant is operated to produce fresh water and by doing simple calculation, one can estimate amount of CO₂ released per day in 2020. By looking at Qatar current status of CO₂ emission per capita which is highest in the world, the projection of water demand and its carbon footprint is significant and solutions have to be considered.

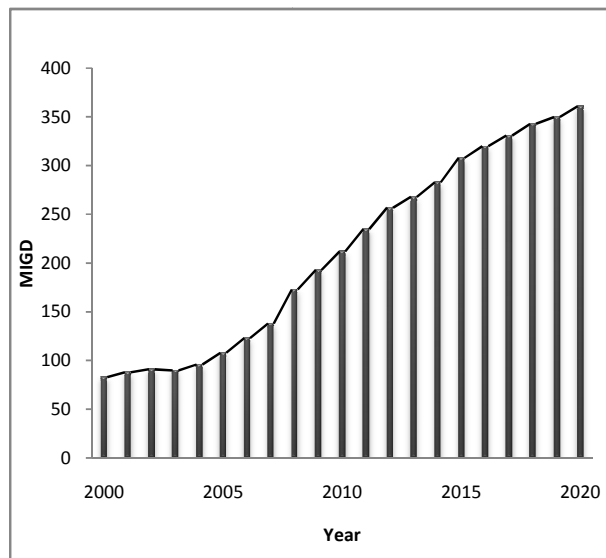

Fig. 1 Current and forecasted water demand in state of Qatar [6]

The increased use of energy by the desalination plant results in indirect environmental impacts such as air pollution and water pollution which boost the process of global warming. However, the important fact is to recognize between reducing greenhouse gases (GHG) emissions and reducing fossil fuel energy use. One great step to reach this goal is to use renewable energy such as wind or solar energy or through utilization of waste heat which comes from power plant or petrochemical industries in MD process.

Utilizing waste heat has an advantage of leaving its footprint behind while it can be useful to be used in MD process where low temperature is needed and by doing so one can augment water production with same environmental footprint.

The niche application of MD process in GCC countries would be by utilizing waste heat where no much capital and operating cost would be required for pumping, building infrastructure, and water intake while producing more water with same amount of water intake used before and same environmental and carbon footprints [7].

Due to high energy consumption, the desalination industry is worsening air pollution through NO_x and SO₂ emissions. However, NO_x emissions are decreasing due to technological upgrades and SO₂ emissions fluctuate depending if oil is used instead of natural gas. In addition, the water production sector is the second largest emitter of CO₂ and contributor to climate change after the oil sector in GCC countries. Fossil fuel consumption in desalination plants is expected to continue to increase as new desalination capacity becomes operational with the increasing water demand.

Increasing and growth of desalination in GCC region and other part of the world have shifted attention to the role of desalination in alleviating water shortages. It has been proved that desalination technology has developed to a level where it can be seen as reliable source of water at a price comparable to water from conventional sources such as rivers or aquifer. As

it is seen desalination will remain in GCC countries as the most feasible alternative to augment or meet future water supply requirements but many concerns rise over potential negative impacts on the environment such as the concentrate and chemical discharges to the marine environment, the emissions of air pollutants and the huge energy demand of the processes.

Effects of traditional desalination technologies are long and among those are huge land use, impingement and entrainment of sea organism due to large feed intake, emission to atmosphere such as CO₂, NO_x, and SO_x due to considerable amount of energy needed to run the desalination process. A key concern is concentrated rejected brine and chemicals which may have adverse effect on water and sediment quality and damage marine life [8].

To reduce the effect of desalination process some solution has been raised and one of them is using Membrane distillation desalination as an alternative to augment fresh water supply with low energy cost, low expenditure, and minimum environmental footprint.

A. Membrane Distillation (MD)

Membrane distillation (MD), which is hybrid between thermal desalination and porous hydrophobic membrane as non-wetting contact media, is currently gaining increasing attention in membrane processes with significant advantages than most of traditional thermal desalination process and reverse osmosis (RO).

MD is a separation process using a porous hydrophobic membrane consisting of three main steps: evaporation water in feed side, (ii) followed by transport of water vapor molecules to permeate side through membrane pore and (iii) condensation of vapor molecules in cold permeates side.

Depending on the way how vapor pressure difference as driving force and vapor condensation are employed, four different configurations of MD are available, namely: direct contact membrane distillation (DCMD), air gap membrane distillation (AGMD), sweeping gas membrane distillation (SGMD), and vacuum membrane distillation (VMD) [7].

Membrane distillation (MD) is a thermally driven technology developed over 60 years where hydrophobic membrane sheets are used to separate hot and cold stream of water and allows water to evaporate due to temperature difference. Nature of hydrophobic membrane allows water vapor to pass and rejects the liquid water. Difference in temperature in the two sides of membrane is the driving force where cause water to vaporize and condense on the cold surface. The result of this physical-chemical operation is distillate with almost 99.99% salt rejection [7]. Unlike conventional desalination technology such as MSF and RO, MD does not suffer from salt entrainment which is non-volatile [9].

The process starts with passing the saline solution from other sources on one side of the membrane at an elevated temperature, for example 70-80°C. At the other side of the membrane, a lower temperature water at around 30-40°C, creates a water vapor partial pressure difference between the

two sides of the membrane and allows the evaporation through the membrane. The water vapor goes through the pores of membrane and condenses on the low-temperature side and distillate is formed.

One of the widely used MD technologies in the literature and labs is DCMD. Direct contact MD (Fig.2 (a)), the feed solution is in direct contact with the membrane on one side and cold distillate (permeate) is in contact with another side of the membrane and first introduced by Lawson and Lloyd [10], Martinez-Diez and Florido-Diez [11], Phattarawik and Jiratanon [12]. The temperature of the feed solution is higher than that of the permeate solution to create a driving force for vapor transport across the membrane. If the purpose of the process is to desalinate seawater, the permeate solution is fresh water. Because the membrane is the only barrier between both solutions, the water vapor flux in direct contact MD is relatively high. Unfortunately this is also true for the energy flux by heat conduction, so that heat losses in direct contact MD are also relatively high. DCMD is well operated for applications where aqueous solutions are needed to be concentrated [4], [10], [12]-[16].

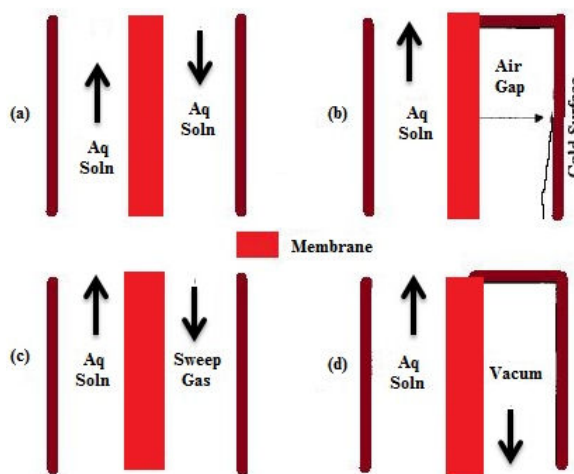

Fig. 2 Different MD configuration (a) DCMD, (b) AGMD, (c) SGMD, (d) VMD

In this study bench scale DCMD is used to evaluate the flux produced by this technology and to compare the quality of distillate water with that of other technologies.

The reason behind superior water quality in MD process is use of hydrophobic membrane which allows vapor to pass and rejects liquid water.

Due to use of hydrophobic membrane in MD process, feed liquid must not go through the membrane pores and cause membrane wetting. This fact is related to the applied pressure on the membrane in which it has not to exceed a limit known as liquid entry pressure (LEP). LEP is a function of the maximum pore size and the membrane hydrophobicity. It is directly related to feed concentration and the presence of organic solutes, which usually reduce the LEP [17]. LEP can be estimated using the Laplace (cantor) equation reported by numbers of literature which relate maximum pore size to other

operational parameters such as [13]-[14]:

$$\Delta P = P_f - P_d = \frac{-2B\gamma_l \cos\theta}{r_{\max}} \quad (1)$$

where P_f is hydraulic pressure on the feed side, P_d is the permeate side hydraulic pressure, B is a geometric pore coefficient, γ_l is liquid surface tension, θ is contact angle of water with membrane surface and r_{\max} is the maximum pore size.

The contact angle is phenomena resulted due to free energy of the surface and the liquid, solid, and vapor. Contact angle in membrane science is introduced to describe the relative hydrophobicity of a membrane surface. In very strong hydrophilic membrane which is membrane with ability to allow liquid to enter the pores, the liquid is attracted to the solid surface and the droplet will completely spread out throughout the membrane solid surface and the contact angle will be close to 0° . Less hydrophilic membranes have Contact angle of between 0° to 90° [18]. For hydrophobic membrane which is membrane with tendency to resist liquid entering the pores the contact angle will be larger than 90° . The contact angle of hydrophobic membrane varies between 90° to 150° or even nearly 180° . On the hydrophobic membrane surfaces, water droplets simply rest on the surface, without actually wetting the membrane surface [18]. Contact angle of membrane is estimated using Young's equation as:

$$\gamma_l = \gamma_s + \gamma_{lv} \cos\theta \quad (2)$$

where γ_l is liquid interfacial tension, γ_s is solid interfacial tension and γ_{lv} is vapor liquid interfacial tension. Fig. 3 describes each one of above in details.

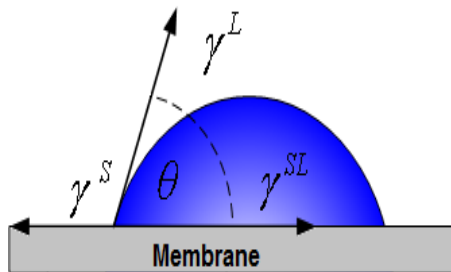

Fig. 3 Parameters of Young's equation

It is worth mentioning that in Young's equation, the contact surface is assumed to be completely flat. Table III summarizes contact angle and surface energy of some popular membrane used in MD process.

TABLE III
CONTACT ANGLE AND SURFACE ENERGY OF SOME COMMONLY USED MEMBRANES [18]

Membrane material	Contact angle	Surface energy ($\times 10^3$ N/m)
Polytetrafluoroethylene (PTFE)	108° to 115°	19.1
Polyvinylidene fluoride (PVDF)	107°	30.3
Polypropylene (PP)	120°	30

According to the Laplace (cantor) equation and considering all parameters, a membrane having higher contact angle (high hydrophobicity), smaller pore size, lower surface energy and high surface tension for the feed solution will have higher LEP value.

According to [18] a membrane with pore size of about $0.2 \mu\text{m}$, the LEP is around 2-4 atm and for pore size of around $0.45 \mu\text{m}$, the LEP decreases up to 1 atm [19].

In operating MD, special care has to be taken in order to avoid membrane wetting which allows water to penetrate the membrane pores and terminate evaporation process and cause problems and affect the water quality.

Set of test are conducted to measure the contact angle of membrane sheet used in this study and will be shown in later sections.

The main objectives of this study are to evaluate flux of such system and evaluate effect of fouling on the performance of the DCMD flux after long operation run. Quality of water is analyzed and compared to that of thermal desalination process.

II. MATERIALS AND METHODS

A bench scale single stage DCMD module was designed and tested in a system including feed flow and coolant recirculation flow metering plus connected ancillary equipment with data acquisition system (Fig.4).

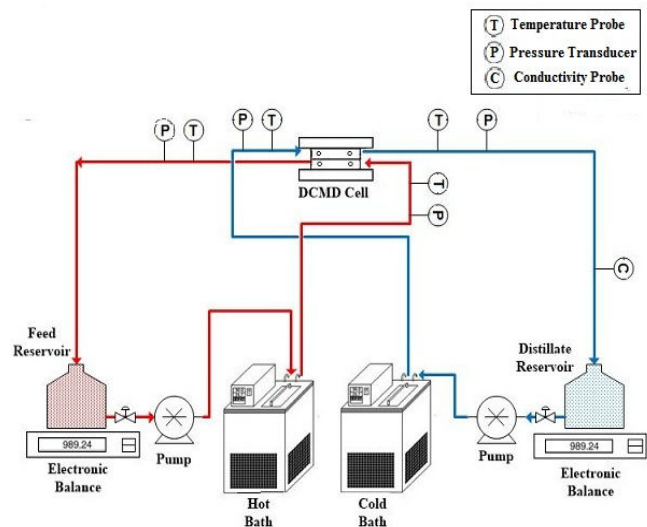

Fig. 4 Process flow diagram of DCMD bench scale unit

The membrane used in this study is made of Poly Tetra Fluoro Ethylene (PTFE) hydrophobic membrane with support of Poly Propylene (PP) sheet to provide strength and a degree of rigidity during the tests. The flat sheet PTFE membranes (Sterlitech Corporation, US) had a pore size of $0.22 \mu\text{m}$, and thickness of $175 \mu\text{m}$ (both active layer and support layer) and an active area of 0.014m^2 (of total area of 0.0203m^2).

The feed velocities in both sides of the membrane were controlled using peristaltic pumps (Thermo Scientific model: FH100X, US). Deionized water (conductivity $< 2 \mu\text{S/cm}$) was

used as the cold flow to the MD unit. Temperature and pressure of the inlet and outlet streams of the membrane module were monitored using thermo resistance RTDs (Model: RTD-NPT-72-E, Omega Engineering, UK) and pressure transducers (Model: PX309-030GI, Omega Engineering, UK). The digital data display system (Model: DP25B-E-230-A, Omega Engineering, UK) was used to monitor feed and distillate flow rate, temperature, and pressure of the streams. The flux of distillate was measured by the weight of the distillate using weighing balance (Model: VWR# 97035-640, Mettler Toledo) through active membrane area and time. Distillate conductivity was monitored using conductivity indicator (model: 3433E8A, 10 cell constant, Hatch, USA). The data was saved using a National Instruments data acquisition hardware (Chasis Model cDAQ9188; Module Model: NI-9219, National Instruments, US). The weight from the balance was acquired using a serial server (Model: NI ENET 232, National Instruments, USA). Data storage and processing was developed using LAB View data acquisition software. The temperature of the feed liquid and distillate side was varied and controlled using heating and cooling circulators (Model: F32-MA, Julabo, Germany).

Different feed solutions were used in this study to compare effect of salinity on permeate flux and they are: thermal reject brine, seawater, and synthetic NaCl saline solution. Seawater was collected from open intake of Arabian Gulf; thermal reject brine was collected from Qatari MSF thermal desalination plant, and synthetic brine 100,000 ppm ANALAR grade NaCl solution. Characteristic of the feed solutions are given in Table IV.

TABLE IV
PH AND EC OF FEED SOLUTIONS USED IN THE EXPERIMENTS

Solution	Conductivity (mS/cm)	pH
Rejected Brine	76.8	8.378
Sea Water	65	7.6
NaCl Solution	132.5	6.975

A. Scanning Electron Microscopy(SEM)Analysis

To observe fouling on the membrane, original and used membranes are analyzed using the SEM imaging. FEI Quanta 200 Environmental Scanning Electron Microscope (ESEM) with a resolution of 5nm and a magnification X200K was used.

To get the images and study the surface characteristic of the membranes, sample of membrane was frozen in liquid nitrogen and then fractured. Cross section and surface of the membrane were sputtered with gold and then transferred to the microscope for imaging.

B. Contact Angle Analysis

A Contact Angle Measuring Instrument DSA30 from KRUSS GmbH was used to measure the contact angle of a PTFE membrane using the sessile drop method as follows: deposition of a liquid droplet onto the membrane surface using an I-shaped needle and deionized (DI) water was used as a liquid and the angle of the drop with the membrane is measured using the Young equation, assuming that surface is

smooth and homogeneous [20]. Five readings were measured and an average was obtained from the results.

C. Membrane Distillate Flux

The flux (J) is found experimentally by taking the difference in the weight of distillate tank over certain time under given experimental conditions. Distillate flux (measured as kg/m²h and reported as LMH) is calculated as:

$$\text{Distillate flux} = \frac{\text{Difference in weight of distillate tank (kg)}}{\text{Membrane Area (m}^2\text{)} \times \text{Time (h)}} \quad (3)$$

D. Membrane Characteristic

PTFE membrane filters contain a membrane made of pure PTFE laminated onto a polypropylene non-woven layer is used in experiments. Membranes are from Sterlitech Corporation in US. The main properties of the membrane are tabulated in Table V.

TABLE V
PROPERTIES OF PTFE MEMBRANE

Description	Specification
Pore size	0.22 μm
Thickness	175 μm thick
Pore Size Range	0.2 to 1.0 micron
Diameter	13 mm to 142 mm circles, rectangles or rolls
Sterilization	Auto-clavable up to 130 °C
Membrane Active Area	0.014 m ²

E. Chemical Analysis

The chemical compositions of the seawater and brines are one of the major parameters needed to be analyzed for any desalination technology. Quality of the distillate produced from DCMD bench scale unit is analyzed by Inductive Coupled Plasma (ICP) and Ion Chromatography (IC) and the salt rejection was measured based on difference between initial feed concentration and final distillate concentration as stated in (4). Generally, salt rejection percentage of the system is defined as:

$$Y = \frac{C_f - C_p}{C_f} \times 100 \quad (4)$$

where, C_f and C_p are salt concentration of feed and salt concentration of permeate, respectively.

III. RESULTS AND DISCUSSION

A. Contact Angle Analysis

Contact angle of polymer is commonly used to estimate the hydrophobicity and wetting properties of polymer surface. As mentioned earlier, larger contact angle represents hydrophobic surface while smaller angle represents hydrophilic surface.

A Contact Angle Measuring Instrument DSA30 from KRUSS GmbH was used to measure the contact angle of a PTFE membrane using the sessile drop method as follows: deposition of a liquid droplet onto the membrane surface using an I-shaped needle and DI water was used as a liquid and the angle of the drop with the membrane is measured using the Young equation, assuming that surface is smooth and

homogeneous [20]. Five readings were measured and an average was obtained from the results. Figs. 5 and 6 show the equilibrium state of a distilled water droplet on a flat-sheet membrane for PTFE and PP membrane, respectively.

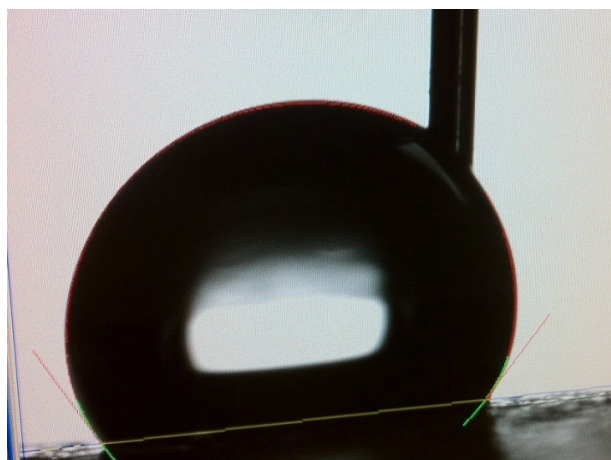

Fig. 5 Equilibrium state of a distilled water droplet on a flat-sheet membrane active layer (PTFE)

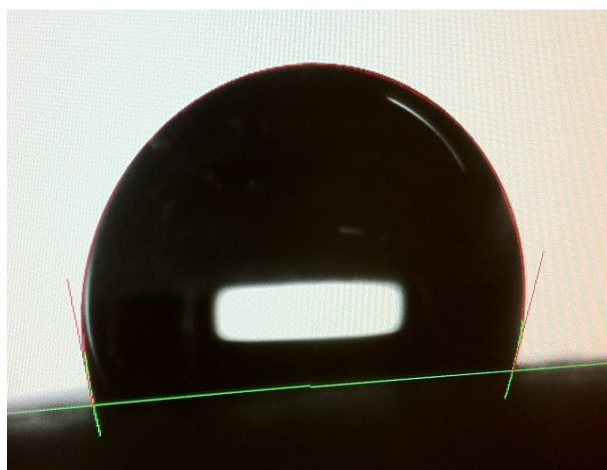

Fig. 6 Equilibrium state of a distilled water droplet on a flat-sheet membrane support layer (PP)

Contact angle of both sides are measured and reported in Table VI for PTFE layer (active side) and Table VII shows the contact angle for PP layer (support side).

TABLE VI
CONTACT ANGLE MEASUREMENTS FOR PTFE MEMBRANE

Run	θ (Left) [deg]	θ (Right) [deg]	θ (Average) [deg]	
1	121.9	132	126.95	±5.05
2	121.9	132	126.95	±5.05
3	121.9	132	126.95	±5.05
4	121.9	132	126.95	±5.05
5	121.9	132	126.95	±5.05

TABLE VII
CONTACT ANGLE MEASUREMENTS FOR PP MEMBRANE

Run	θ (Left) [deg]	θ (Right) [deg]	θ (Average) [deg]	
1	101.6	107.4	104.5	± 2.93
2	101.6	107.4	104.5	± 2.93
3	101.6	107.4	104.5	± 2.93
4	101.6	107.4	104.5	± 2.93
5	101.6	107.4	104.5	± 2.93

As shown in Tables VI and VII, the high contact angles obtained can be attributed to the high hydrophobicity of the membrane. The hydrophobic nature of membrane permit only vapor to pass and rejects water, ensuring high selectivity in the process of MD. It can also be seen that both sides of the membrane are hydrophobic since the contact angle of both sides are higher than 90 degree but hydrophobicity of PTFE side is higher than that of PP side. Contact angles measured are consistent with the values reported in literature [23]. Higher contact angle in combination with other factors such as smaller pore size, lower surface energy and higher surface tension lead to higher liquid entry pressure be greater than the pressure difference at the membrane's liquid/vapor interface to prevent pore wetting. Pore wetting lead to penetration of liquid water and affect the quality of fresh water produced. Also, low contact angle leads to reduction inability of membrane to reject non-volatile feed [21].

According to literature [21], the flux of MD was found to be dependent on surface contact angle. Membranes with lower surface energy (lower contact angle) compared to those with higher contact angle, have less tendency for pore wetting. Moreover, as the membrane hydrophobicity increases, thermal conductivity of the membrane decreases [21]. This is desirable in DCMD operation, since it reduces the heat losses by conduction across the membrane and avoids the establishment of strong heat polarization layers on the membrane interface and in the membrane pores [22].

Similar tests were conducted in literature and similarly showed the same result. Study by Zhang et al. [23] using PTFE and PVDF membranes indicated that PTFE membranes can have contact angle up to 140° and average of 126° is commonly reported in most of literature [24].

Zhu et al. [25] reported that the contact angle can be affected by the membrane surface composition, pore size and roughness. According to their studies, contact angle of PTFE hollow fibers membrane is in range of 125° which is almost to the results found in these report.

Wenzel [26] considered analytical relationship between roughness and contact angle and concluded that for hydrophobic surfaces, the contact angle increases with increasing roughness according to the Wenzel equation:

$$r = \frac{S_{eff}}{S_{flat}} = \frac{\cos\theta_{mean}}{\cos\theta_{flat}} \quad (5)$$

where θ_{mean} is the measured contact angle and θ_{flat} is what the contact angle would be if the surface were flat. S_{eff} and S_{flat} denote the effective and projected (flat) surface area, respectively. According to his study, contact angle of 122 °

were reported for PTFE membrane.

Adnan et al. [27] tested different PTFE membrane from different source and contact angle of 126° up to 165° were reported in their studies.

B. Permeate Flux

To check and confirm reproducibility of the system, different tests under different operating parameters are conducted and the flux profiles are generated.

All tests are repeated three times to ensure quality and avoid error. Values reported in this section are average values.

Area of membrane used in the study is 0.014m². Fig.7 show the flux profile of different feed solution at constant feed inlet and permeate inlet temperature operating under constant pressure and flow rate.

It has been observed that concentration of feed has some effect on the flux of membrane due to decreases in water activity by increasing the feed concentration, decrease in mass transfer coefficient of feed side boundary layer by increasing feed concentration due to increase in concentration polarization, decrease in heat transfer coefficient by increasing salt concentration due to reduction in membrane surface, vapor pressure of water decreases by increasing salt concentration, and by decrease in heat transfer coefficient

Reynolds number decreases and this is due to increase in viscosity of solution by increasing salt concentration.

Increasing permeate temperature; decrease the flux as shown in Fig. 8. Higher vapor pressure can be obtained in principal by decreasing permeate temperature. In general three factors help in increasing flux when increasing feed temperature or decreasing permeate temperature and they are:

- Increasing vapor pressure due to feed temperature
- Increasing driving force due to higher ΔT due to reduction of permeate temperature
- Increasing temperature polarization due to increase of feed temperature [11]

In contrast to permeate temperature, feed temperature, as shown in Fig. 8, increases the flux of permeate produced. This can be explained with increasing driving force which is vapor pressure at higher temperature; mathematically it is related to vapor pressure and temperature using Antoine equation. Values reported here are in consistent with literature [15].

Quality of water used as feed and also quality of distillate produced are summarized in Table VIII. Table IX summarizes the average flux of different tests performed using bench scale unit. In all the experiments flow rate of 1.5 L/min is used for both hot and cold side.

TABLE VIII
QUALITY OF FEED SOLUTIONS USED IN THE TESTS AND DISTILLATE PRODUCED FROM DCMD

Parameter	Unit	Seawater	Brine	NaCl Solution	Distillate	Salt Rejection (%)
Conductivity	μS/cm	65000	76800	132500	4.2	<99.99
TDS	ppm	41600	49100	100000	2.69	<99.99
Calcium	mg/l	459	52	51	<0.1	<99.99
Magnesium	mg/l	1147	1738	9	<0.1	<99.99
Sodium	mg/l	12858	18434	41228	0.8	<99.99
Potassium	mg/l	343	491	4.8	<0.1	<99.99
Chloride	mg/l	19661	32127	59605	0.9	<99.99
Sulfate	mg/l	3013	4025	87	<0.1	<99.99
Bromide	mg/l	32	46	4.7	<0.1	<99.99

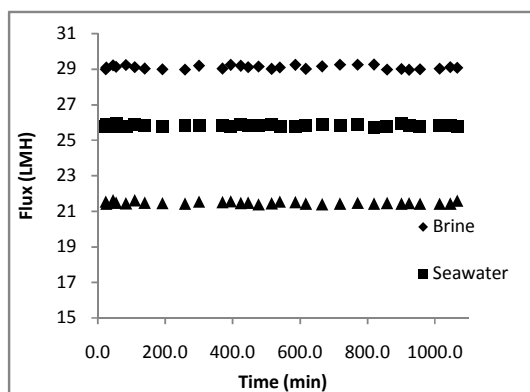

Fig. 7 Flux profile of different feed at $T_i=70^\circ\text{C}$, $T_p=30^\circ\text{C}$, $Q=1.5$ L/min

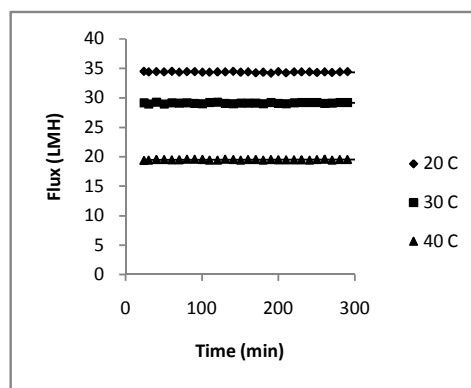

Fig. 8 Flux profile of constant feed temperature and different permeate temperature ($T_i=70^\circ\text{C}$, $Q=1.5$ L/min, thermal brine)

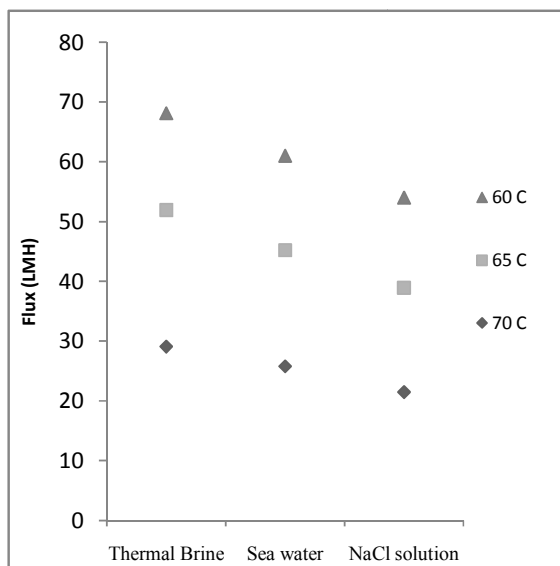

Fig. 9 Effect of feed concentration and feed inlet temperature on permeate flux ($T_p=30\text{ }^\circ\text{C}$, $Q=1.5\text{ L/min}$)

TABLE IX
AVERAGE FLUX OF DIFFERENT FEED SOLUTION AT DIFFERENT TEMPERATURE USING FLOW RATE OF 1.5 L/MIN

Temperature ($^\circ\text{C}$)		Flux (LMH)		
Hot side	Cold side	Thermal Brine	Sea water	NaCl solution
70	20	34.3	31	25
70	30	29.1	25.8	21.5
70	40	19.6	18.2	13.3
65	20	23.3	21.4	18.7
65	30	22.8	19.4	17.4
65	40	11	9.9	8
60	20	23	21.4	18.5
60	30	16.2	15.8	15.1
60	40	6.5	6	5.2

C. Water Quality

Feed solutions and the distillate produced with MD system are analyzed with ICP and IC tests and results are summarized in Table VIII. As it is clear from Table VIII, the distillate produced is highly pure and there is no much of salt went through the membrane to the distillate. The salt rejections for all salts are 99.99%. It is clearly indicated throughout the tests that temperature has no effect on the quality of distillate produced. This is due to the hydrophobicity of membrane which is not function of temperature and regardless of feed temperature the vapor produced is pure and salts are rejected at membrane surface.

D. Membrane Characterization

Scanning electron microscopy (SEM) is a microscopic method capable of producing very high magnification images of a membrane surface. Due to the manner in which the image is created, SEM images have a characteristic three-dimensional appearance and are useful for judging the surface structure of the sample. Used and new membranes after 17 hours of continuous operation are analyzed and shown in Figs.10 and 11,

respectively.

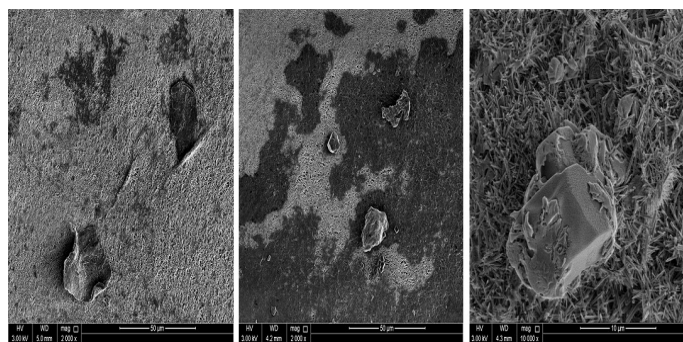

Fig. 10 SEM image of used membrane after operation with (a) NaCl solution (b) Rejected brine (c) Seawater

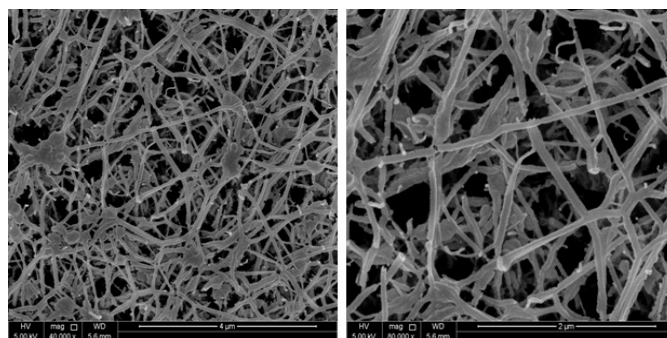

Fig. 11 SEM image of original membrane before usage

It was observed that Membranes did not show evidence of serious fouling layer after 17 hour of operation with seawater, rejected brine, and NaCl solution as flux did not decline by time and worked constantly. Small fouling layer was observed on membrane operated on seawater and was found to consist primarily of calcium carbonate. The presence of the anti-scalant in the brines as compared to the seawater is likely the reason for no fouling layer observed on the MD membranes [7].

The flat sheet membrane is used due to its higher flux compared to hollow fiber sheets [21]. The reported flux from flat sheet membranes in literature is typically $20\text{--}30\text{ L m}^{-2}\text{ h}^{-1}$ [21] at operating temperature of $60\text{ }^\circ\text{C}$ and $20\text{ }^\circ\text{C}$. The polymeric membrane used in the experiment consists of, a thin active layer made of PTFE and a porous support layer made of PP. This structure provides sufficient mechanical strength for the membrane to enable the active layer to be manufactured as thin as possible, which reduces the mass transfer resistance. PTFE membranes compared to other polymeric membrane such as PVDF and PP membrane are more appropriate for application of membrane distillation, since they have thinner active layer and support layer.

The porosity of the membranes used is in the range of 0.7 to 0.75, the pore size is $0.22\text{ }\mu\text{m}$, and the thickness is $175\text{ }\mu\text{m}$ thick. Thermal conductivity of the PTFE membrane is reported in literature as $0.22\text{--}0.45\text{ W m}^{-1}\text{ K}^{-1}$ [22]. PTFE is used due to its higher hydrophobicity (largest contact angle with water), good

chemical and thermal stability and oxidation resistance, but it has the highest conductivity which will cause greater heat transfer through PTFE membranes [21]. The membrane coupons used in the experimental setup has length of 19.1cm and width of 14cm.

IV. SUMMARY AND CONCLUSION

This thesis presents experiments conducted with Direct Contact Membrane Distillation (DCMD) configurations. With many advantages, MD is promising technology for fresh water production but different enhancement and optimization has to be done on the MD process to get higher acceptance in sea water desalination industry.

Beside its broad advantages, MD requires high thermal energy yet relatively low permeate flux. Different applications of MD have been covered in many literatures so far, but not all applications are economically and practically feasible and not yet available commercially. To be practically implemented and feasible, MD should use free and cheap waste energy such as industrial waste heat from flue gas or other sources. Other factors in improving feasibility of MD might be optimization of process conditions, preparation of novel membranes, module configurations as well as spacers support.

REFERENCES

- [1] "Power in the GCC." Kippreport 8 Feb. 2010: 28.
- [2] Alhajri, K, and L Almisned. "Water Resources In The GCC Countries: A Strategic Option." *Renewable Energy* 5.1-4 (1994): 524-528.
- [3] Al. Ansari, Mohammed Saleh . "Concentrating Solar Power to Be Used in Seawater Desalination within the Gulf Cooperation Council." *Energy and Environment Research* 3 (2013): 1-23.
- [4] Dawoud, Mohamed A., and Mohamed M. Al Mulla. "Environmental Impacts of Seawater Desalination: Arabian Gulf Case Study." *International Journal of Environment and Sustainability* 1.3 (2012): 22-37.
- [5] Corrado, Sommariva. "Basic Design of Thermal Desalination Process." Workshop. Global Water Sustainability Center. Qatar Science and Technology Park, Doha. 6 Dec. 2011. Class lecture.
- [6] Al-Darwish, AbdulMonem. "Qatar's Strategy in the Sustainable Development of Water Resources." COP 18. KAHRAMA. QNCC, Doha. 28 Nov. 2012. Speech.
- [7] Adham, Samer, Altaf Hussain, Joel MinierMatar, Raul Does, and Arnold Janson. "Application of Membrane Distillation for desalting brines from thermal desalination plants." *Desalination* 314 (2013): 101-108.
- [8] Lattemann, Sabine, and Thomas Hopner. "Environmental Impact and impact assessment of seawater desalination." *Desalination* 220 (2008): 1-15.
- [9] Charcosset, Catherine. "A Review of Membrane Processes and Renewable Energies for Desalination." *Desalination* 245.1-3 (2009): 214-231.
- [10] Lawson, K. "Membrane Distillation. I. Module Design and Performance Evaluation Using Vacuum Membrane Distillation." *Journal of Membrane Science* 120 (1996): 111-121.
- [11] Martinez, L, and F Floridodiaz. "Theoretical and Experimental Studies on Desalination Using Membrane Distillation1." *Desalination* 139.1-3 (2001): 373-379.
- [12] J. Phattaranawik and R. Jiratananon, "Direct contact membrane distillation: effect of mass transfer on heat transfer", *J. Membrane Sci.* 188 (2001), 137-146.
- [13] Lawson, K, and D Lloyd. "Membrane Distillation." *Journal of Membrane Science* 124 (1997): 1-25.
- [14] Elbourawi, M, Z Ding, R Ma, and M Khayet. "A Framework for Better Understanding Membrane Distillation Separation Process." *Journal of Membrane Science* 285.1-2 (2006): 4-29.
- [15] Martinez-Diez, F. J. Florido-Diaz, Theoretical and experimental studies on desalination using membrane distillation, *Desalination*. 139 (2001) 373-379.
- [16] L. Martinez-Diez, F. J. Florido-Diaz, M. I. Vazquez-Gonzalez, Study of evaporation efficiency in membrane distillation, *Desalination*. 126 (1999) 193-198.
- [17] P.K. Weyl, (1967), "Recovery demineralized water from saline waters". United States Patent 3,340,186.
- [18] Zeaman, Leos J., Zydney, Andrew L., *Microfiltration and Ultrafiltration, Principles and Applications.*, New York: Marcel Dekker, Inc, 1996.
- [19] Cath, T. "Experimental Study Of Desalination Using Direct Contact Membrane Distillation: A New Approach To Flux Enhancement." *Journal of Membrane Science* 228.1 (2004): 5-16.
- [20] Baek, Youngbin ,Junil Kang, Patrick Theato, and Jeyong Yoon. "Measuring hydrophilicity of RO membranes by contact angles via sessile drop and captive bubble method: A comparative study." *Desalination* 303 (2012): 23–28.
- [21] Camacho, Lucy Mar ,LudovicDumée, Jianhua Zhang Zhang, Jun-de Li, Mikel Duke, Juan Gomez, and Stephen Gray. "Advances in Membrane Distillation for Water Desalination and Purification Applications." *Water* 5 (2013): 94-196.
- [22] Zhang, Jianhua, Noel Dow, Mikel Duke, Eddy Ostarcevic, Jun-De Li, and Stephen Gray. "Identification of Material And Physical Features Of Membrane Distillation Membranes For High Performance Desalination." *Journal of Membrane Science* 349.1-2 (2010): 295-303.
- [23] J. Zhang, N. Dow, M. Duke, E. Ostarcevic, J.-D. Li, S. Gray, Identification of material and physical features of membrane distillation membranes for high performance desalination, *Journal of Membrane Science*. 349(2010): 295-303.
- [24] Hwang, Ho Jung, Ke He, Stephen Gray, Jianhua Zhang, and IlShik Moon. "Direct Contact Membrane Distillation (DCMD): Experimental Study on The Commercial PTFE Membrane And Modeling." *Journal of Membrane Science* 371.1-2 (2011): 90-98.
- [25] Zhu, Hailin ,Hongjie Wang, Feng Wang, YuhaiGuo, and Huapeng Zhang. "Preparation and properties of PTFE hollow fiber membranes for desalination through vacuum membrane distillation." *Journal of Membrane Science* 446 (2013): 145-153
- [26] Wenzel, Robert N. "Resistance of Solid Surfaces To Wetting By Water." *Industrial & Engineering Chemistry* 28.8 (1936): 988-994.
- [27] Adnan, Sharmiza ,Manh Hoang, and Huanting Wang. "Commercial PTFE membranes for membrane distillation application: Effect of microstructure and support material." *Desalination* 284 (2012): 297–308.