

# Risk Level Evaluation for Power System Facilities in Smart Grid

Sung-Hun Lee, Yun-Seong Lee, and Jin-O Kim

**Abstract**—Reliability Centered Maintenance(RCM) is one of most widely used methods in the modern power system to schedule a maintenance cycle and determine the priority of inspection. In order to apply the RCM method to the Smart Grid, a precedence study for the new structure of rearranged system should be performed due to introduction of additional installation such as renewable and sustainable energy resources, energy storage devices and advanced metering infrastructure. This paper proposes a new method to evaluate the priority of maintenance and inspection of the power system facilities in the Smart Grid using the Risk Priority Number. In order to calculate that risk index, it is required that the reliability block diagram should be analyzed for the Smart Grid system. Finally, the feasible technical method is discussed to estimate the risk potential as part of the RCM procedure.

**Keywords**—Expert System, FMECA, Fuzzy Theory, Reliability Centered Maintenance, Risk Priority Number

## I. INTRODUCTION

THE Reliability Centered Maintenance (RCM) is a method based on reliability of components in the system. As RCM is being studied, maintenance task can be performed effectively through the Risk Priority Number (RPN) evaluation about the component in the system [1]. In order to apply the RCM method to the Smart Grid, a precedence study for the new structure of rearranged system should be performed. Therefore, an analysis for system structure should be necessary, and that can be performed by the RPN analysis. The RPN provides engineers with the maintenance priority order among facilities in the system by evaluating Severity(S), Occurrence(O) and Detection(D) about facilities. The Severity means seriousness about effect of failures. The Occurrence is a frequency number of failures. And the Detection is a potentiality of finding out failures [2]. The RPN informs the risk level of facilities and the priority order of maintenance task, however if there is no sufficient historical failure data, it is difficult to calculate the RPN [3]. In this case, historical failure data from other sources can be used and this data can be applied to our system. However if historical data from other sources is used without any process, there will be concomitant problems according to a discord of each system characteristic, an uncertainty of failure rate, a difference between the present and the date of failure data from other sources and etc.

Because of those, through the expert opinion system, failure rates of facilities must be estimated according to circumstance of system. Also traditional RPN calculation has a problem that RPN is calculated simply by multiplications [2], [4]. In this paper, a new methodology is proposed to model the failure rate as a fuzzy membership function to settle these problems. This method is based on failure data from other sources by means of the fuzzy theory and the expert opinion system. And considering assessment tendency of each expert, distortions that happened when the failure rates of facilities is estimated were minimized. These results determine Occurrence values of facilities. Taking advantage of this result, the Risk Priority Number can be calculated with Severity and Detection of facilities by using the fuzzy operation. In section 2, before assessment of the Occurrence for Power System Facilities in Smart Grid, the failure rates of facilities were estimated through expert opinion system considering assessment tendency of each expert. In section 3, the method for assessing the Severity, Occurrence and Detection is described. In section 4, the proposed method is applied to the power substation system in the Smart Grid.

## II. DETERMINATION OF THE FAILURE RATE

Because the Occurrence can be evaluated by using the failure rate of the facility in the Smart Grid, at first the failure rates of the facilities must be determined. However if there is no sufficient historical failure data such as power facilities, historical failure data from other sources must be used as a substitute. When the failure data substituted is used, it is necessary to process the failure data from other sources through the expert opinion system. If projective assessments evaluated by experts are reflected on determination of the failure rate, the extreme assessment tendency of some experts will distort the results excessively. Therefore it is proposed a new methodology to determine the failure rate using the expert assessment matrix reflecting tendency of experts. And fuzzy theory is used to express the uncertainty of failure data.

### A. Expert Assessment Matrix

Experts evaluate the failure rates of facilities in our system based on work experience, aging of facilities, operation condition, and level of technology in comparison with the failure data from other sources. The Expert Assessment Matrix,  $X$ , is defined composition of expert's assessments as (1). A row of the matrix means a sort of facility, a column of the matrix means each expert.

S. H. Lee, Y. S. Lee and J. O. Kim are with the Department of Electrical Engineering, Hanyang University, Seoul, Korea (e-mail: shlee@kwater.or.kr, lypd@hanyang.ac.kr, jokim@hanyang.ac.kr).

$$X = \begin{bmatrix} X_{11} & X_{12} & \cdots & X_{1j} \\ X_{21} & X_{22} & \cdots & X_{2j} \\ \vdots & \ddots & & \vdots \\ X_{i1} & X_{i2} & \cdots & X_{ij} \end{bmatrix} \quad (1)$$

where  $i$  is a sort of facility and  $j$  represents each expert.

The assessment values is in the range of integer, 1~10. The lower value than a point of reference, 5, means that failure rate of this facility is lower than the failure rate from other sources relatively. In case of the contrary, the failure rate of the facility is higher than that of other sources relatively. As described above, there are problems in expert system as following statements. Some experts having a very small deviation tendency of assessment for all facilities will distort the results from other experts' lower value or higher value relatively. That is, the failure rates will be under-estimated or over-estimated due to a very small deviation of assessment from some experts. On the contrary, other experts having a very large deviation tendency of assessment will distort the results. Also from the viewpoint of the facility, when a facility is evaluated as a lower value from most of experts, the result may be distorted due to only a few of experts having extreme tendency of assessment.

Based on this logic, the Expert Assessment Matrix must be revised so that it is proposed the Revision Matrix reflecting Expert's Tendency,  $\Delta X$  in this paper. The components of  $\Delta X$  is calculated as (2).

$$\Delta x = \frac{\sigma_j}{\rho_i} \times \frac{x_{ij} - m_{x_i}}{n} \quad (2)$$

where  $\sigma_j$  is a standard deviation of components of  $j$  column in  $X$ ,  $\rho_i$  is a standard deviation of components of  $i$  row in  $X$ ,  $x_{ij}$  represents a component in  $X$ ,  $m_{x_i}$  is a mean of components of  $i$  row in  $X$ , and  $n$  is the number of experts. In (2),  $\sigma_j$  represents a tendency of experts,  $\rho_i$  represents a standard deviation for assessment of facilities by experts. According to (2), assessment will be upward if  $\sigma_j$  of the expert doing that assessment is large. On the other hand, from the viewpoint of the facility, if a facility was estimated with lower value or higher value from a few of experts than other experts relatively due to extreme tendency of assessment, the result will be downward because of  $\rho_i$ . For a magnitude of revision effect, it is reflected a difference between  $x_{ij}$  and  $m_{x_i}$ .

The Revision Matrix reflecting Expert's Tendency,  $\Delta X$  consists of negative or positive values according to assessment tendency of each expert. Applying (2) to (1), it could be obtained Revised Expert Assessment Matrix,  $X_{rev}$  as (3).

$$X_{rev} = X + \Delta X \quad (3)$$

where components of  $X_{rev}$  range 0~10.

### B. Weighting Vector of Experts

It is necessary that assessments by each expert are weighted according to title, work experience, educational level, age and etc[5]. It could represent as a vector, (4).

$$W = \begin{bmatrix} \omega_1 \\ \omega_2 \\ \vdots \\ \omega_n \end{bmatrix} \quad (4)$$

where  $n$  is the number of experts, and  $\omega_n$  represents weighting factor of the expert.

### C. Assessment Vector of Failure Rate

For applying the weighting factor to the Revised Expert Assessment Matrix, it could be obtained the Assessment Vector of Failure Rate,  $X_{new}$  as (5).

$$X_{new} = X_{rev} \times W \quad (5)$$

There exist rows in  $X_{new}$  as the number of facilities. Components in  $X_{new}$  mean assessments of experts about the failure rate of facilities in the system in comparison with failure data from other sources. It is reflected not only assessment tendency of each expert but also the weighting factors of experts.

### D. Expression of the Failure Rate as a Fuzzy Function

For expression of the failure rate as a triangle fuzzy function [6], the fuzzy membership function is composed as Fig. 1.

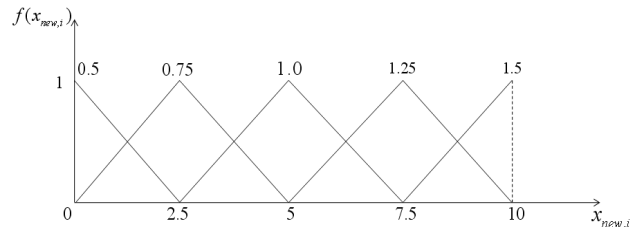

Fig. 1 Fuzzy membership function for expression of the failure rate

Using the Assessment Vector of Failure Rate, the method that the failure rate is expressed as a fuzzy function is following (6) ~ (8). The center value of fuzzy function is determined as (6).

$$\lambda_c = c_1 f_{c1}(x_{new,i}) + c_2 f_{c2}(x_{new,i}) \quad (c = 0.5, 0.75, 1.0, 1.25, 1.5) \quad (6)$$

where  $\lambda_c$  is a center value of fuzzy function,  $x_{new,i}$  is an assessment of the failure rate for facility,  $i$ , and  $c$  is a weighting value of each fuzzy membership function. In expressing the failure rate as a fuzzy function, there are two fuzzy membership function value for one assessment of failure

rate to calculate the lower limit and upper limit. In (6), two terms,  $c_1 f_{c1}(x_{new,i})$  and  $c_2 f_{c2}(x_{new,i})$  each include the uncertainty about lower limit and upper limit of a fuzzy function of the failure rate. Those lower limit and upper limit are calculated as (7) and (8).

$$l = \lambda_c - \frac{\rho_i \times \min\{c_1, c_2\}}{n'} \tag{7}$$

$$u = \lambda_c + \frac{\rho_i \times \max\{c_1, c_2\}}{n'} \tag{8}$$

where  $l$  is a lower limit of fuzzy function of the failure rate,  $u$  is a upper limit of fuzzy function of the failure rate,  $\rho_i$  is a standard deviation of components of  $i$  row in  $X$ , and  $n'$  is a coefficient related the number of experts. Because a concomitant uncertainty is larger as the estimation value for the failure rate is larger, the lower limit and upper limit each are calculated with a minimum value or a maximum value as (7) and (8). And if the deviation of assessment from each expert is large, it means that the uncertainty is large. On the other hand, the number of experts affects a magnitude of the lower limit and the upper limit contrary.

III. CALCULATION OF THE RISK PRIORITY NUMBER

The RPN is the value to determine order of maintenance task, and it is assessed in the range of 1~10 in this paper.

The Severity is determined using the reliability block diagram analysis. Composing facilities of the system as the reliability block diagram, the minimal cut set(MCS) could be obtained, and then the Severity is calculated as (9).

$$Severity_i = \frac{\sum_{j=1}^{M.O} \sqrt{\omega} \times N_{ij}}{\sum_{j=1}^{M.O} N_{ij}} \tag{9}$$

where  $\omega$  is a effect value of a failure of each component,  $M.O$  is a maximum order of MCS, and  $N_{ij}$  is the number of MCS for facility  $i$  in  $j$ -order.

To calculate the Occurrence, the failure rate model expressed as a fuzzy function is used. A process is necessary to normalize the value of the failure rate model as (10).

$$Occurrence_i = 5 + \frac{\lambda_{c,i} \times \lambda_i - m_o}{\sigma_o} \tag{10}$$

where  $\lambda_{c,i} \times \lambda_i$  is the estimation value of failure rate for facility  $i$ ,  $m_o$  is a mean of the estimation value of failure rate for all facilities, and  $\sigma_o$  is a standard deviation of the estimation value of failure rate for all facilities.

The Detection is determined using a mean delay time which is required between a failure event and a repair action. Similar to the Occurrence, it is necessary to normalize a mean delay time.

$$Detection_i = 5 + \frac{T_i - m_d}{\sigma_d} \tag{11}$$

where  $T_i$  is a mean delay time of facility  $i$ ,  $m_d$  is a mean of  $T_i$  for all facilities, and  $\sigma_d$  is a standard deviation of  $T_i$  for all facilities. For the RPN calculation using the fuzzy operation, the S and D are merged in a fuzzy function using (12).

$$C_{S,D} = \frac{Severity + Detection}{2}$$

$$l_{S,D} = \min[Severity, Detection] \tag{12}$$

$$u_{S,D} = \max[Severity, Detection]$$

where  $C_{S,D}$  is a center value of merged fuzzy function,  $l_{S,D}$  and  $u_{S,D}$  each represent the lower limit and upper limit of the merged fuzzy function. Finally, the Occurrence fuzzy function and the merged fuzzy function (Severity and Detection) are combined as the PRN fuzzy function using  $\alpha$ -cut operation[7]. The RPN is determined by the horizontal value of the center of gravity of the RPN fuzzy function.

IV. CASE STUDY

The proposed method using the fuzzy theory and expert system is applied to the power substation system such as in Fig. 2 (a). And Fig. 2 (b) is a reliability block diagram of the power substation system.

The MCS could be obtained from Fig. 3, and using (9), the Severity evaluation is performed. The results are in TABLE I.

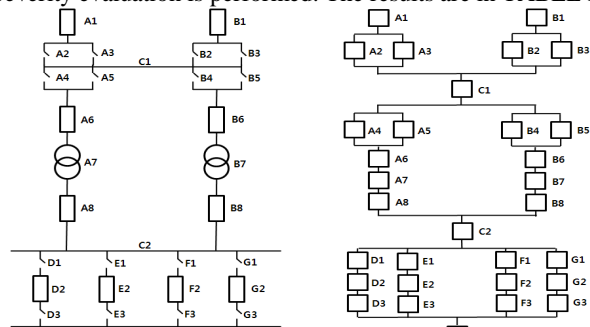

(a) Substation system (b) reliability block diagram  
Fig. 2 Power substation system and reliability block diagram

TABLE I  
SEVERITY EVALUATION

Facility	Code of facilities	Severity
Gas Circuit Breaker	A1, A6, A8, B1, B6, B8, D2, E2, F2, G2	4.09
Transformer, Station	A7, B7	4.95
Switch	A2, A3, A4, A5, B2, B3, B4, B5, D1, D3, E1, E3, F1, F3, G1, G3	2.73
Bus	C1, C2, C3	10.0

TABLE III  
OCCURRENCE EVALUATION

Facility	Occurrence		
	Lower limit	Center value	Upper limit
Gas Circuit Breaker	4.46	6.47	8.98
Transformer, Station	1.24	5.36	10.00
Switch	1.68	3.96	7.00
Bus	1.18	4.21	8.25

For the Occurrence evaluation, the assessment of experts is assumed as in Table II. In Table II, the mean value is arithmetical average of assessments, and the revised value is calculated using proposed method. From Table II, the Occurrence evaluation is performed, the results is showed in Table III. The Detection evaluation is assumed as in Table IV. Table IV shows the comparison between traditional method using multiplication and proposed method using fuzzy theory and expert system considering the assessment tendency. In traditional method, Severity(10.0) for bus is not reflected the RPN relatively, so that the priority order of bus is lower. However, through the reliability block diagram analysis, the bus is verified as the most important facility than other facilities. For Gas circuit breaker and Station transformer, Station transformer has a little larger RPN than that of Gas circuit breaker both a traditional method and the proposed method.

## V. CONCLUSION

In this paper, a new methodology is proposed in modeling the failure rate as a fuzzy function for power system facilities in the Smart Grid and in calculating the RPN to determine priority order for maintenance tasks using the fuzzy operation and expert opinion system.

Considering the assessment tendency, the distortion of results for the Occurrence evaluation is minimized. Therefore, reasonable results could be obtained using the fuzzy operation in calculating the RPN. For calculation of the risk level, the Severity, Occurrence, and Detection could be considered in balance in calculating the RPN, and the priority order for maintenance can be obtained.

TABLE II  
ASSESSMENTS FOR THE FAILURE RATE

Facility	Assessments of Experts					Mean Value	Revised Value	Failure rate
	Expert. 1	Expert. 2	Expert. 3	Expert. 4	Expert. 5			
Gas Circuit Breaker	8	7	6	6	7	6.80	7.05	$1.2715 \times 10^{-5}$
Transformer, Station	9	6	7	4	5	6.20	6.18	$8.3405 \times 10^{-6}$
Switch	2	2	5	3	4	3.20	2.60	$2.2896 \times 10^{-6}$
Bus	1	2	5	4	4	3.20	2.65	$3.999 \times 10^{-6}$

TABLE IV  
COMPARISON BETWEEN A TRADITIONAL METHOD AND THE PROPOSED METHOD IN CALCULATING RPN AND DETERMINATION OF PRIORITY ORDER

Facility	S	O	D	RPN by multiplication	Priority order by multiplication	RPN by proposed method	Priority order by proposed method
Gas Circuit Breaker	4.09	6.47	5.00	132	2	5.19	3
Transformer, Station	4.95	5.36	5.50	146	1	5.28	2
Switch	2.73	3.96	4.00	43	4	3.61	4
Bus	10.00	4.21	3.00	126	3	5.79	1

## REFERENCES

- [1] J. Moubra , "Reliability-Centered Maintenance", Butterworth-Hinemann, 1995.
- [2] John B. Bowles, "An Assessment of RPN Prioritization in a Failure Modes Effects and Criticality Analysis", Proceedings Annual Reliability and Maintainability Symposium, 2003.
- [3] Kai Meng Tay, Chee Sing Teh, David Bong, "Development of a Fuzzy-logic-based Occurrence Updating model for Process FMEA", Proceedings of the International Conference on Computer and Communication Engineering , 2008.
- [4] Hai-Chao Ran, Li-Hua Sun, Ying-Jun Guo, Jin-Feng Zhang, "A Fuzzy Method For Risk Quantitative Analysis of System Failure", Proceedings of the 5th International Conference on Machine Learning and Cybernetics, 2006.
- [5] Dong Yuhua, Yu Datao, "Estimation of failure probability of oil and gas transmission pipelines by fuzzy fault tree analysis", Journal of Loss Prevention in the Process Industries, No.18, 2005, p83-88.
- [6] Tong Wu, Guangyu Tu, Z Q Bo and A Klimek, "Fuzzy set theory and fault tree analysis based method suitable for fault diagnosis of power transformer", Intelligent Systems Applications to Power Systems, 2007.
- [7] Sadaaki Miyamoto, "Fuzzy Sets in information retrieval and cluster analysis", Kluwer Academic Publishers, 1990.

**Sung-Hun Lee** received the M.S. degrees in electrical engineering from Hanyang University, Seoul, Korea, in 2007. He is currently a Ph.D. candidate in department of electrical engineering of Hanyang University and researching in reliability centered maintenance.

**Yun-Seong Lee** received the B.S. degree in electrical engineering from Hanyang University, Seoul, Korea, in 2008. He is currently a Ph.D. candidate in department of electrical engineering of Hanyang University. His research interests include reliability centered maintenance, system diagnosis and optimal maintenance planning.

**Jin-O Kim** (SM'03) received the B.S. and M.S. degrees in electrical engineering from Seoul National University, Seoul, Korea, in 1980 and 1983, respectively, and the Ph.D. degree from Texas A&M University, College Station, in 1991. He is presently a Professor with the Department of Electrical and Control Engineering, Hanyang University, Seoul. His research interests include power system reliability, planning, and power economics.