

Research on Strategy for Automated Scaleless-Map Compilation

Yin Jie, Qin Qiming, Yin Yong

Abstract—As a tool for human spatial cognition and thinking, the map has been playing an important role. Maps are perhaps as fundamental to society as language and the written word. Economic and social development requires extensive and in-depth understanding of their own living environment, from the scope of the overall global to urban housing. This has brought unprecedented opportunities and challenges for traditional cartography. This paper first proposed the concept of scaleless-map and its basic characteristics, through the analysis of the existing multi-scale representation techniques. Then some strategies are presented for automated mapping compilation. Taking into account the demand of automated map compilation, detailed proposed the software - WJ workstation must have four technical features, which are generalization operators, symbol primitives, dynamically annotation and mapping process template. This paper provides a more systematic new idea and solution to improve the intelligence and automation of the scaleless cartography.

Keywords—scaleless-map, strategy, map generalization, automated compilation, WJ workstation.

I. INTRODUCTION

As a tool for human spatial cognition and thinking, the map has been playing an important role. Maps are perhaps as fundamental to society as language and the written word. Economic and social development requires extensive and in-depth understanding of their own living environment, from the scope of the overall global to urban housing. This has brought unprecedented opportunities and challenges for traditional cartography. Scaleless-Map came into being to a true understanding of the continuous expression of any object in the world, breaking the traditional map with scale-bound limitations and providing zoom in and zoom out at any scale on our study area. Scaleless-Map, on the one hand, meet the requirements of the continuity of thinking, the other is consistent with the visual perception of human beings, ensuring that the user's visual experience and the habit of thinking is consistent. The World Wide Web has changed the perspective on the role that maps can play. With the development of network technology, Scaleless-Map will greatly expand the geographic information services results.

Yin Jie is with Peking University, No.5 Yiheyuan Road Haidian District, Beijing,100871,China, and Chinese Academy of Surveying and Mapping, No.28 Lianhuachi Road Haidian District,Beijing,100830,China (phone: 8601-6388-0552; fax: 8601-6388-0630; e-mail:yinjie@casm.ac.cn).

Qin Qiming is with Peking University, No.5 Yiheyuan Road Haidian District, Beijing,100871,China(phone: 8601-6275-4674).

Yin Yong is now with Chinese Academy of Surveying and Mapping, No.28 Lianhuachi Road Haidian District, Beijing, 100830, China (e-mail: yinyong@casm.ac.cn).

Judging from the form of representation, the scaleless-map is the map information automatically adapt to continuous changes in the display range and with different levels of detail. From a visual perspective, the scaleless-map is one of the map representation combining the advantage of computer technology and the visual sensation mechanism [1]. At present, the establishment of scaleless-map depends on multi-scale representation. But as a new type of map products, the problems it faces is that there is not a complete theory and methodology. Map compilation still use the specification and process for traditional paper maps, which leads to low efficiency and also affects the quality of a map.

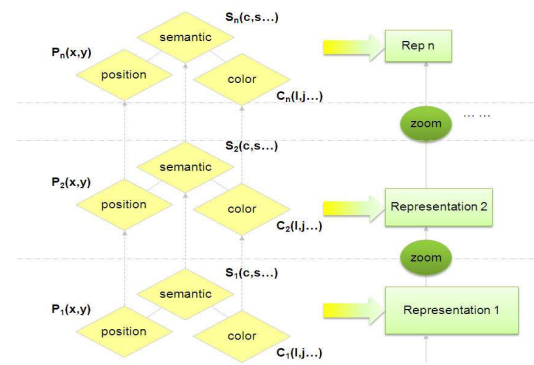

Fig. 1 Scaleless-map representation

II. AUTOMATED SCALELESS-MAP COMPILATION

Human awareness and research of the real world, originally with a scale features. Scaleless-map is the expression of progressive visualization of the real world. The ideal scaleless-map is based on a large-scale spatial database, automatically increase or decrease the amount of information in a certain region of space with the scale change, the map can be compatible with the user perspective compression and reproducibility. In this process, along with cartographic generalization. According to the status of cartographic generalization, this paper think that we should take some strategies to the implementation of the automated mapping.

The first strategy is the step-by-step and item-by-item breakdown of the implementation. The strategy is to select and determine the mapping content, steps and action items according to specific conditions and actual needs, phased individual to the operation [2]. Level of cartography in general processes: data processing, symbolization, and annotation placement, were designed corresponding processing module, the complex mapping links and technology decomposition to simplify and improve efficiency.

The second is to focus on the mathematical model operating under the control of the knowledge reasoning. Cartographic generalization process, for example, the role of the method of specific mathematical models and expert knowledge reasoning method is different. The former is to complete the specific operation, such as the shape of the simplified trade-offs, etc.; the latter is mainly used in the process of judgment and links. Therefore, the two closely integrated, will it be possible to get satisfactory results. It can be said that the expert knowledge reasoning assumes control, the mathematical model is responsible for the specific implementation.

In this paper, the strategies are tested during the design of scaleless cartographic software—WJ workstations.

III. WJ WORKSTATION

Existing features and graphics from the map, which we call the direct information. The map also does not come from the symbol itself, but to the distribution and combination of elements to reflect the analysis of information obtained indirectly referred to as indirect information. Map production and design point of departure in this paper concern the direct information. Direct information including semantic, position, color and annotation, these four information are independent of each other four systems, so direct information can be calculated as follows:

$$I_{\text{map}} = H_s + H_a + H_p + H_c$$

- 1) Semantic information. The measure is mainly symbolic, involving the classification and grading, and the corresponding number of symbols.
- 2) Annotation information. Map a variety of annotation, and in general can be divided into text annotation (such as residential and annotation) and digital annotation (such as elevation annotation).
- 3) Location information. Each surface features on the map are the graphics and geometric position. Users recognize objects by its position and graphics. According to the scale represented by surface features can quickly measure out the size of the surface features and determine the distribution. This kind of information can be obtained by measuring the coordinates, the location of surface features on Earth's surface, or the relative position of other surface features. Failing to scale symbols can measure the coordinates of the anchor point.
- 4) Color information. Any one color is expressed by three quantities: hue, brightness and saturation.

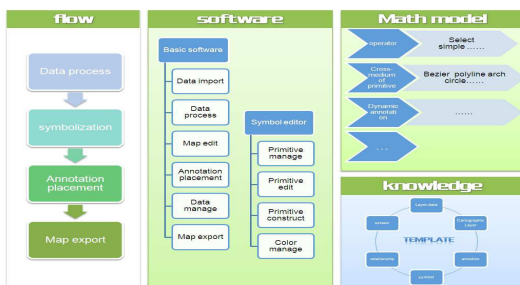

Fig. 2 WJ-workstation structure design

According to the analysis of information, WJ workstation is designed in this paper to complete the map compilation automatically. The workstation consists of five parts, including basic software, symbol editor, color correction software, professional map rendering engine and graphics card. Among them, the basic software part and symbol editor function part are the core of the automated mapping, color correction software is used to protect a variety of output consistency in color, graphics card and professional map rendering engine expands the field of application of graphic expression and to enhance the efficiency of drawing. The main features of the workstation reflected in the synthesis operator, refined primitive model of cross-media, annotation of dynamic configuration, and mapping of process templates.

IV. FOUR TECHNICAL FEATURES

A. Refinement of Generalization Operators

For a long time in the past, researchers have been committed to a fully automated map generalization research. They hope to some extent simulate or imitate the thinking process of cartographer, so the computer can "observe" and "think" like a cartographer. Map generalization is an extremely complex intelligent analysis of the decision-making process. It is impossible to achieve fully automated map generalization at this stage, due to the constraints of current computer technology development. Therefore, we inevitably want to join the decision-making and intervention in this process. Weibel and Buttenfield first pointed out that we should achieve a balance between people and computers to accomplish map generalization automatically based on the possible ways solving problem. The computers are used to complete the easy-to-solve problems, but they need to rely on human knowledge to make decision and control. The computer can put together a combination of an operator to complete a task from the perspective of automatic map generalization is an engineering problem of. Map generalization operators should be the various subsystems in the entire engineering system. The operator is not the algorithm, it is a problem or a solution to the problem, it is a specific operation in software. Map generalization operators should be a collection of relatively independent sub-problems in the map generalization problem. Thus, taking into account the automatic map generalization is the engineering of a project highly, we first in-depth study the map automatically process then propose map generalization operators subset. For each operator can have a variety of synthesis algorithms, these algorithms is the comprehensive transformation tools, and thus must be accurate, clear, can be performed in the computer. Operator + integrated solutions strategy, coherence can complete a series of generalization tasks to compile a map.

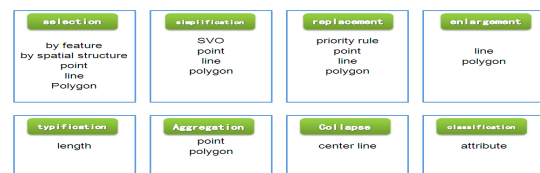

Fig. 3 Generalization operator

Cartographic generalization is in the interactive environment using a variety of operators, algorithms and parameters, so it is important to determine how to execute a generalization under different circumstances. The scale of change, the type of map products, the characteristics of the data will affect the application of the operator, algorithms and parameters. So we have to build as much as possible to refine the integrated operator algorithm library, to adapt to different needs.

B. Cross-medium of Graphic Primitives

Before the widespread availability of the computer, the drawing of maps and map symbols are completed by cartographer by hand. With the advent of electronic maps, map symbols are drawn in the computer through the procedures of the various programming languages. For a variety of GIS software, maps are displayed on the screen, its role is to complete a variety of analysis functions. GIS symbol library does not consider the map of cross-media visualization output. A variety of digital mapping systems rarely consider the needs of cross-media output level from the symbol library. Therefore, the map output tends to cause loss or distortion of the symbolic information.

With the continuous extension of the network terminal customers, scaleless-map face to show the diversity of media. The map symbol is the expression of the basic means of the map content. In one sense, the fidelity of the map of cross-media is essentially a visualization of the cross-media output of the map symbol. The goal is to make a map symbol library system can be used for the visualization of a variety of terminal output, both for the maps screen, but also for the maps printing, network distribution and transmission to meet the needs of visualization of cross-media output for mapping system and GIS system, in the information age. Compared to the GIS symbol library or Cartographic symbol library, map symbols supporting cross-media output have the following characteristics: Basic primitives of the symbols in the design, drawing, storage, to meet the demand for cross-media output; The accuracy of the symbol not only can meet the needs of the screen display, and to meet the publishing and network visualization needs [3]; The symbol library should have the color management functions.

Point, line and area symbols not only have their own characteristics, but also have some common properties. Their difference lies constitute a symbol of primitives and their properties, the layout in different ways. Rather their drawing parameters(symbol code, the color of the pen, brush color, etc.) and methods of operation(drawing, delete, etc.)are the same. Therefore, we use object-oriented thinking to abstract symbols. We believe that the symbol is composed of a series of primitives. In this way, any one symbol can be decomposed into the smallest unit of the structure - primitive.

In accordance with the theory of computer graphics, this paper established the 14 kinds of primitive model(polyline, s-pine curves, circles, ellipses, rectangles, fan-shaped, arc, polygon, closed s-pine curve, arch, text, texture, Bezier curves, closed Bezier curves) for cartographic representation according to the characteristics and type of cartographic objects.

Symbol library with 14 kinds of primitive model has the flexibility, ease of use, accuracy, standards and scalability.

In order to support multi-media fidelity, we construct a strict mathematical relationship between the primitives of each model and Bezier curves. Bezier curve as a primitive, compared to other linear, has its unique advantages. Bezier curve can replace almost all linear, that is to say, all the points, lines can be expressed by the Bezier curve. Cross-media features can be naturally transmitted to the map symbols due to the Bezier curve pervasive variety of platforms.

- Bezier curves $P_{ij}=(1-t)^i P_{j-1} + t P_i + 1 - j - 1, j=1, n, i=0, n-j$;
- Polyline($P_0=P_1, P_2=P_3$) ;
- B-Spline curves ($P_0!=P_1, P_2!=P_3$) ;
- Arc(P_0, R, A, B) ;
- Polygon ($p_0=p_1, p_2=p_3, \text{Closed}$) ;
- Rectangle($p_0=p_1, p_2=p_3, \text{Closed}, z, p_0 p_1 p_2 = z p_1 p_2 p_3$) ;
- Circle($P_0, R, A=0, B=2\pi$) ;
- Ellipse ($P_0, R, A=0, B=2\pi, \text{yscale}$) ;
- Arch($P_0, R, A, B, \text{Closed}$) ;
- Fan-shaped($P_0, R, A, B, Lra, \text{Closed}$) ;
- Closed spline curve ($p_0!=p_1, p_2!=p_3, \text{Closed}$) ;
- Closed Bezier Curve (Bezier, Closed) ;
- Text is the logical combination of Bezier

C. Dynamic Placement of Annotation

Map annotation no longer has a fixed location, but need to dynamically select the location and display in real time, based on the current scale and area of the screen. Reasonable annotation placement should follow certain principles, such as "relationship", "avoidance", "habit". In other words, annotation and its feature should be correctly associated; annotations shouldn't overlap and should avoid the important features; the position and the arrangement should meet the reading habits and so on. Our idea is: First, we can optimally annotation placement, respectively, to the point, line and area features, solve the local optimum configuration of a layer; Next, we build a global optimization of container, including annotation and optimization algorithm of the optimization; Ultimately, to solve the overall global optimum.

The following is automatic annotation methods for point, line, polygon features.

1. We will use the tabu search optimization algorithm for the automatic annotation of the point feature.

The main processes are:

First construct the initial solution, and calculate the conflicting annotation number, annotation intersect each point record with its checkbox, and other points of elements; Then consider taboo table and amnesty rules, including the size of the candidate set of iterative computation, the size of the tabu list,

the value of the annotation on behalf of, the objective function value, until the termination rules. For this algorithm, the determination of parameters had a greater impact in the optimization of efficiency and effectiveness.

After testing, we determined the size of the tabu list, the candidate set size is 10, achieved good results in practical applications.

2. *The main processes about automatic annotation along the line feature are:* Simplified line data according to Douglas algorithm; Select the center of the annotation or parallel line annotation; We propose the use of the reference line to solve the parallel lines for parallel lines annotation; Segmentation processing should made on the long line, in order to segment the annotation; The positioning of annotation should be made for each linear feature annotation, including the position of annotation characters and the orientation of the prefix.

The key is to strike a high-quality parallel lines about the automatic annotation algorithm along a line features. Parallel lines generated by the traditional angle bisector method has one drawback that is the point on the small angle, the obtained points are very far away from the centerline. To solve this problem, we take two steps:

The first step is to solve the problem that inside the parallel lines point retraction and change shape. The solution of this problem is to generate the reference line of the parallel lines, to strike a parallel line through the reference line generated.

The second step is to solve the problem that prominent lateral point of the parallel lines. The solution to this problem is to improve the angle bisector method, add auxiliary points in the strike parallel lines.

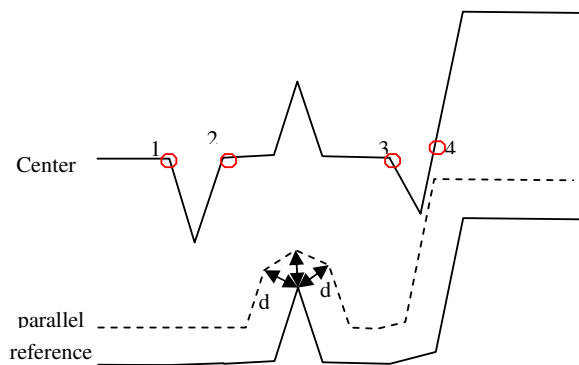

Fig. 4 Improved angle bisector method

3. *There are main skeleton line, boundary line, within the point, simply connected and the hash-style annotation mode for the automatic annotation of the area feature.* For rapid mapping, interior point annotation mode is the most common and most convenient. Here we introduce the polygon internal point generation algorithm:

To any polygon without island, for example First, we compare DX and DY, DX is the length of the minimum bounding rectangle polygons in the X direction, DY is the width

of the minimum bounding rectangle polygons in the Y direction. If $DX > DY$, draw perpendicular to the X-axis linear in the $DX / 2$ locations. Calculate the intersection of the straight lines and polygons, Y1, Y2, Y3, Y4, Y5, Y6, which Y1 largest, Y6 minimum. Then parity pairing, such as the distance between Y1 and Y2 is Dy1, the distance between Y3 and Y4 is Dy2, the distance between Y5 and Y6 is Dy3. Comparison, obtained Dy2 the maximum value. The polygon internal point coordinates is: $((X_{min} + X_{max}) / 2, (Y_3 + Y_4) / 2)$. Similarly, if $DY > DX$, the polygon internal point coordinates is: $((X_i + X_{i+1}) / 2, (Y_{min} + Y_{max}) / 2)$. X and X (i + 1) distance is the maximum away from the perpendicular to the Y-axis of a straight line drawn through the $DY / 2$.

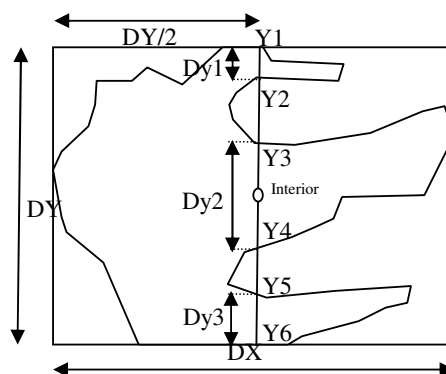

Fig. 5 Interior point of the polygon without island

D. Template of Cartographic Process

After a thorough analysis of existing cartographic process, the whole process from data to map can be broke down into six process, such as layered of GIS data, overlap processing, annotation placement, symbolic expression, layered of cartographic data and screen expression. For each process, we established the open expert knowledge templates by summing up the experience of refined cartographic experts, thus achieving the automated processing of the cartographic process.

1. Template of layered GIS data information

The role of this template is the automatic layered data in accordance with the elements of the code, easy to follow-up mapping compilation. The system first looks for the data path, the program will automatically find the corresponding data layer name in the template, and then generates the corresponding layer under the field name.

2. Template of overlap process information

The role of this template is to complete the automatic loading of data, and deal with the overlay relationship between map features. Use the template, it will automatically load the data based on the template layer from top to bottom order and solve the overlapping relationship between the features .Different load according to the different types of layers.

3. Template of annotation placement information

The role of this template is to create the annotation layer configure it. The design of this template includes a data part and the data manipulation part. The data portion is the annotation configuration.

The data manipulation part include records to browse, add, delete, modify and save functions. Annotation of configuration items include: annotation fields, text arrangement, baseline rotation angle, rotation angle of the character, whether crispening, crispening width, crispening color, whether hollow, font style, text format, font, font name, font size, font color, font, spacing, word width, x, y.

4. Template of symbols information

Symbol template is symbolic of the template layer elements. Symbol template design includes a data part and the data manipulation part. The data part is the configuration of symbols; data manipulation part of the browsing records, increase, delete, modify and save the functional design. Use the template, the program automatically according to the template symbolic layer feature. Symbol configuration items include: layer name, symbol picture, symbolic type, the main number, auxiliary number, symbol color, fill color, fill flag, the symbol width, the symbolic point of view, symbol linewidth, the line color and the symbol name.

5. Template of layered cartographic data information

With this template, you can rename the layers in the map project, in line with the tradition of mapping rules to facilitate the mapping to view.

6. Template of screen expression information

With this template, you can achieve multi-scale data integration, you can set the maximum display scale and minimum display scale for each layer. This template can also control the scale factor for each feature.

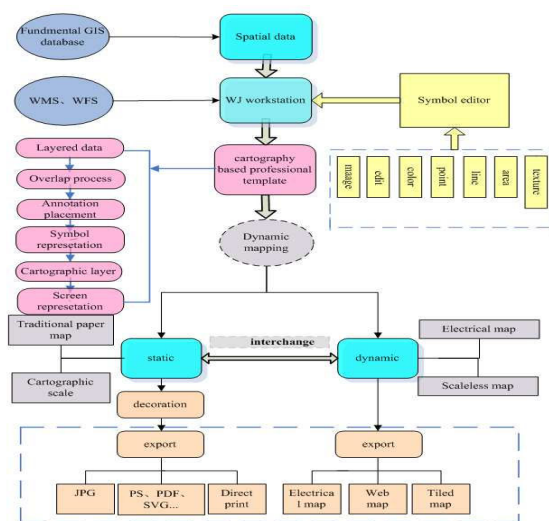

Fig. 6 Cartographic process

V. CONCLUSION

This paper help to solve the critical problems of automated scaleless-map production. It will improve the automatic and comprehensive response strategy to promote the widespread application of the scale-less map. But the study of scaleless-map related to map design, software implementation and application mode and many other content, we need to further breakthroughs in the theory and technical problems.

ACKNOWLEDGMENT

Authors thank Dr. Chengming Li from Chinese Academy of Surveying and Mapping for his helpful proposals. This work was supported in part by the Demonstration Project of Digital Regional Geo-spatial Framework Construction of SBSM, China (Grant No.1469990624204), and Chinese National Programs for High Technology Research and Development (Grant No. 2009AA121404).

REFERENCES

- [1] Cecconi, A. (2003), Integration of Cartographic Generalization and Multi-Scale Databases for Enhanced Web Mapping, University of Zurich.
- [2] Brassel, K. E. & Weibel, R. (1988), A review and conceptual framework of automated map generalization International Journal Of Geographical Information Systems, 1988, 2, 229-244.
- [3] Sester, M. and Brenner, C. (2004). Continuous generalization for visualization on small mobile devices. In P. Fisher, editor, Developments in Spatial Data Handling – 11th Int. Symp. on Spatial Data Handling (SDH'04), pages 355–368. Springer Verlag.

Yin Jie, Associate Researcher. She was born in Henan province, China, in 1973. She graduated from Department of Cartography and GIS, Wuhan Technical University of Surveying and Mapping, China, and obtained her Master Degree in 1999. Her major field of study is symbol design of thematic map. She has been engaging in the research of data share and digital city for a long time and has got several awards. From 2006, she was working on Demonstration Project of Digital Regional Geo-spatial Framework Construction of SBSM, China. Her main interests center on the theory of generalisation and multiple representation.