

# Reconfiguration of Deregulated Distribution Network for Minimizing Energy Supply Cost by using Multi-Objective BGA

H. Kazemi Karegar, S. Jalilzadeh, V. Nabaei, A. Shabani

**Abstract**—In this paper, the problem of finding the optimal topological configuration of a deregulated distribution network is considered. The new features of this paper are proposing a multi-objective function and its application on deregulated distribution networks for finding the optimal configuration. The multi-objective function will be defined for minimizing total Energy Supply Costs (ESC) and energy losses subject to load flow constraints. The optimal configuration will be obtained by using Binary Genetic Algorithm (BGA). The proposed method has been tested to analyze a sample and a practical distribution networks.

**Keywords**—Binary Genetic Algorithm, Deregulated Distribution Network, Minimizing Cost, Reconfiguration.

## I. INTRODUCTION

NOWADAYS, distribution networks are rapidly growing, therefore an efficient operation method is essential for reducing costs and increasing effective operation. This can be achieved by networks reconfiguration [1]. Several approaches are used to find the optimal configuration with the following subjects:

- Reducing power system losses by using ant-colony and genetic algorithm [2, 3, 4]
- Improving service restoring for the isolated portion of a distribution system [5, 6]
- Enhancing system reliability by introducing an analytical mathematical model [7]
- Improving load factors to facilitate load aggregation in distribution networks [8]
- Improving load balancing by using customer information in a customer information system (CIS) [9]
- Minimizing energy losses by using the genetic algorithm [10, 11]
- Minimizing energy losses by using a heuristic algorithm [12, 13, 14]
- Finding non-inferior solution by using the simulated annealing method [15, 16, 17]

All of the above researches have been done on traditional distribution power systems, but in many countries traditional distribution networks are transforming to deregulated

networks. The main difference between them networks is the existence of many energy vendors with various conditions for selling energy in a competitive price. In this new environment, consumers and Distribution Companies (Disco) have authority to select an energy vendor whose energy price has more interest. As a consequence, the topology of the network changes according to the Discos' decision. On the other hand, energy losses are also important for energy vendors. Therefore, the new challenge is finding the optimal network reconfiguration with considering minimum energy losses and minimum energy supply cost.

This paper focuses on large-scale power distribution systems in a deregulated environment while the other previous researches have been done on traditional and small distribution networks. For this purpose, a multi-objective function in a deregulated environment is considered for finding the optimal configuration. The objective function of the optimization problem is to minimize the cost of power losses including consumer's load cost. The BGA is also used to solve this optimization problem. By altering the open/closed states of switches the configuration of the networks will change. Therefore, the distribution network reconfiguration problem has a discrete or binary nature. A comprehensive computer program in MATLAB has been written to find the optimal configurations of 16-bus & 83-bus deregulated test systems subject to load flow constraints including permissible voltage and current variations.

This paper is organized as follows. In section 2, a review of some basic power market models are presented. In section 3, the proposed objective functions are explained. In section 4, the BGA and algorithm for obtaining the optimal solution is described. In section 5, the numerical results of the test systems are discussed and finally, conclusions are presented in section 6.

## II. POWER MARKET MODELS REVIEWING

There are three main power market models:

- Poolco Model
- Bilateral Contracts Model
- Hybrid Model

The Poolco model is defined as a centralized marketplace that clears market for buyers and sellers. Electric power sellers/buyers submit bids to the pool for the amounts of power that they are willing to trade in the market. Sellers in a

H. Kazemi Karegar is with Electrical and Computer Department of Shahid Beheshti University (SBU), Tehran, Iran(phone: +98-21-29902274; fax: +98-21-22431804; e-mail: h\_kazemi@sbu.ac.ir), Corresponding Author.

S. Jalilzadeh, V. Nabaei, A. Shabani are with Electrical Engineering Department of Zanjan University, Zanjan, Iran, (sa\_jalilzadeh@yahoo.com, vahid.nabaei@gmail.com, shabani\_a@znu.ac.ir).

power market would compete for the right to supply energy to the grid, and not for specific customers.

The bilateral contracts are negotiable agreements on delivery and receipt of power between two traders. These contracts set the terms and conditions of agreements independent of the ISO. However, in this model the ISO would verify that a sufficient transmission capacity exists to complete the transactions and maintain the transmission security.

The hybrid model combines various features of the previous two models. In the hybrid model, the utilization of a Poolco is not obligatory, and any customer would be allowed to negotiate a power supply agreement directly with suppliers or choose to accept power at the spot market price. In this model, Poolco would serve all participants (buyers and sellers) who choose not to sign bilateral contracts. However, allowing customers to negotiate power purchase arrangements with suppliers would offer a true customer choice and an impetus for the creation of a wide variety of services and pricing options to best meet individual customer needs. In our discussion of market structure, we assume the use of a hybrid model [18].

III. PROBLEM STATEMENT

In traditional distribution networks, loss minimization is the primary object of optimal operation. However, besides energy loss minimization, the cost minimization is also suggested as a new objective function in deregulated distribution networks.

The problem can be stated as shown in Fig. 1.

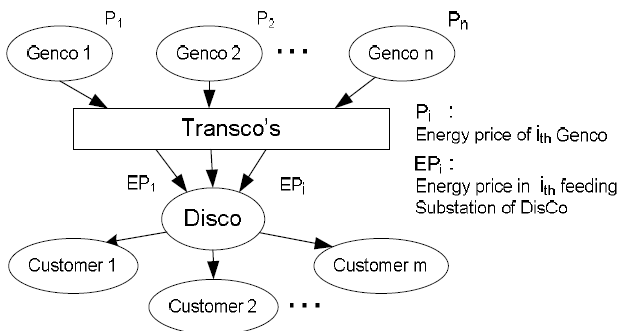

Fig. 1 Disco and other market entities in power system

Disco buys energy from generator companies (Genco's) and transmits it via several transmitter companies (Transco's) to customers. Disco makes some contracts with Genco's and Transco's for buying and transmitting the energy. A Disco should determine the power quantity that each substation delivers to the network during a specific time interval in order to minimize the total energy supply cost with maintaining the service quality considerations. If the network losses are not considered, the solution of the stated problem will be simple, each substation should be utilized in a sequence according to the energy cost, the first one is the cheapest one. Nevertheless, power losses must be taken into account, therefore a special procedure should be developed to obtain a solution, which minimizes the total energy buying cost.

In this paper, it is considered that Disco provides energy according to the bilateral contracts. The total energy supply cost to the consumers during the time interval  $T$  is *Fitness1*:

$$Fitness1 = \sum_{i=1}^n EP_i \left\{ \sum_{k=1}^m \int_0^T P_k(t) dt \right\} \tag{1}$$

Equation (1) can be written as expression (2) when the average power  $P_k$  was considered instead of instantaneous power  $P_k(t)$ .

$$Fitness1 = \sum_{i=1}^n EP_i \left( \sum_{k=1}^m P_k \right) T \tag{2}$$

On the other hand, if the losses at each feeder  $P_{lk}$  are known, then the second objective function *Fitness2* can be expressed as:

$$Fitness2 = \left( \sum_{k=1}^m P_{lk} \right) T \tag{3}$$

As a result, the optimal problem can be formulated as follows:

Objective functions

Minimize:

$$Fitness1 = \sum_{i=1}^n EP_i \left( \sum_{k=1}^m P_k \right) T \tag{4}$$

$$Fitness2 = \left( \sum_{k=1}^m P_{lk} \right) T \tag{5}$$

Subject to:

$$V_{min} \leq |V_k| \leq V_{max} \tag{6}$$

$$|I_k| \leq I_{max} \tag{7}$$

$$P_k \neq 0 \tag{8}$$

Expressions (6) to (8), explain the load and operation constraints. According to the expression (6) and (7), voltages and currents of consumers must be in allowable variations. Expression (8) declares that no feeder section can be left out service.

IV. SOLUTION METHOD

A. String Definition

The open/closed switches change the configuration of a distribution network, hence the states of the switches can be described by a binary string and each state is considered as a gene (binary bits).

State Switch	State Switch	...	State Switch
1	2		n

Each bit accepts only zero or one implying that the corresponding switch is open or close, respectively. For example, the following string describes the situation of

switches in a given distribution network with 16 switches, where the switches 3, 5 and 10 are open.

String = [1 1 0 1 0 1 1 1 1 0 1 1 1 1 1 1]

*B. Adaptive Mutation*

The mutation is usually constant throughout the whole GA search process. However, it has been reported that in the practical application of distribution network reconfigurations, an adaptive mutation process is preferable [19]. Consequently, in this paper an adaptive mutation according follows expression has been used.

$$p(k+1) = \begin{cases} p(k) - p_{step} & \text{Fitness1}(k) \& \text{Fitness2}(k) \text{ unchanged} \\ p(k) & \text{Fitness1}(k) \& \text{Fitness2}(k) \text{ decreased} \\ p_{final} & p(k) - p_{step} < p_{final} \end{cases}$$

(9)

$$p(0) = p_{initial} = 1.0$$

$$p_{step} = 0.001$$

$$p_{final} = 0.05$$

All tables and figures you insert in your document are only to help you gauge the size of your paper, for the convenience of the referees, and to make it easy for you to distribute preprints.

*C. Proposed Method Flowchart*

A flowchart describing the main computational process is shown in Fig. 2.

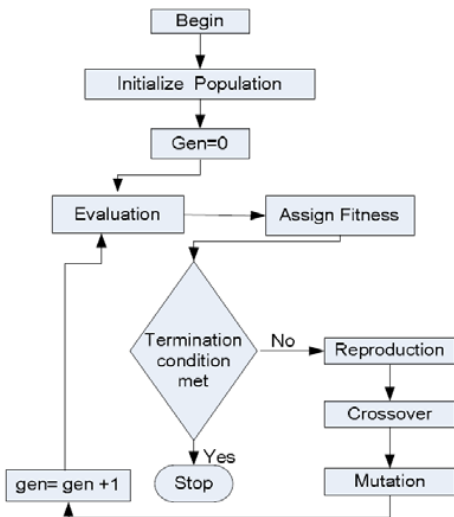

Fig. 2 The flowchart of the proposed method

In this paper, the back/forward sweep distribution power flow is used [20].

V. NUMERICAL RESULTS

To verify the application of the proposed method, two distribution networks are selected. A network with 16-bus is used as case study 1 and the Taiwan distribution network with 83-bus is used as case study 2.

*A. Case Study 1*

A three-feeder distribution network with 16 buses, 13 sectionalizing switches and 3 tie switches as shown in Fig 3 is selected as case study 1. The tie switches are: S15, S21, S26 and the system load is assumed to be constant with  $S_{base}=100$  MW. It is also assumed that a distribution company (Disco) operates this network and supplies the demand power via three feeders 1, 2 and 3. The energy purchase price in the feeding substations 1,2 and 3 are 11.4 \$/MWh, 11.6 \$/MWh and 11.2 \$/MWh, consecutively. The other data of the distribution network is shown in Table I.

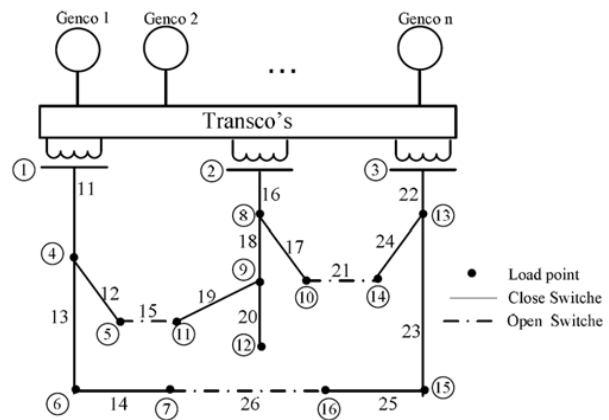

Fig. 3 Three-feeder distribution networks

The parameters of the proposed method for BGA algorithm is also shown in Table II.

If the objective function would be the power loss minimization in a conventional distribution system, then the optimal configuration happened when switches 17, 19 and 26 are opened. In this case, the power loss reduces to 0.00466 P.U. and the total energy supply cost is 8016.62 \$. However, the objective function of the deregulated networks is to minimize the total energy supply cost and power loss minimization. In this case, the total energy supply cost reduces from 8016.62 \$ to 8012.78 \$ when switches 13, 17 and 19 are opened, on the other hand the power loss minimization increases from 0.00466 to 0.00479 P.U. where shown in bold type in Table III. These two cases are shown in Table III as C1 and C2 for traditional and deregulated distribution networks.

Under optimal configuration in the deregulated distribution network, the power loss, feeder-load, energy price and energy supply cost of each feeder are shown in Table IV. As the proof of the proposed method, 190 possible configurations are obtained and the fitness values of the functions *Fitness1* and *Fitness2* are shown in Fig. 4 and Fig. 5, respectively. These figures also indicate the proposed method find the optimum configuration.

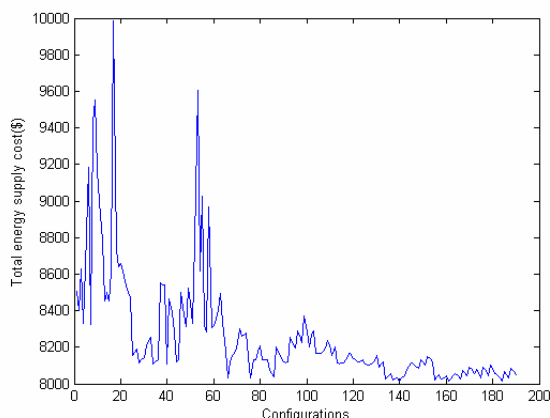

Fig. 4 Total energy supply cost minimization fitness

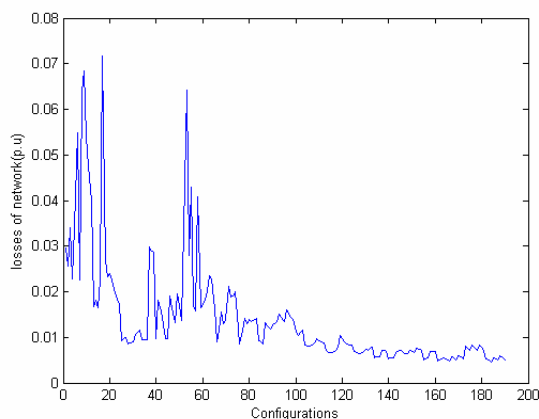

Fig. 5 Loss minimization fitness function

**B. Case Study 2**

The second example is a practical distribution network of Taiwan Power Company. It is a three-phase, 11.4 kV system with 11 feeders, 83 normally closed sectionalizing switches, and 13 normally open tie switches which is shown in Fig. 6. Three-phase balance and constant load are assumed. It is also considered that a distribution company (Disco) operates this network and supplies the demand power in its feeding substation via 11 feeders A,B,C,D,E,F,G,H,I,J,K. The other information of the network is shown in Table V.

For this case, the parameters of the proposed method are show in Table VI. The optimal solution obtained after 690 iterations. For the optimal configuration the share of the each feeder is shown in Table VII. In addition the comparison between the deregulated and conventional distribution network is also explained in Table VIII. Table VIII shows that the total energy supply cost will be reduced to 7723.7 US\$ whereas the power losses will be increased to 0.48464 P.U. in compare with conventional distribution power system

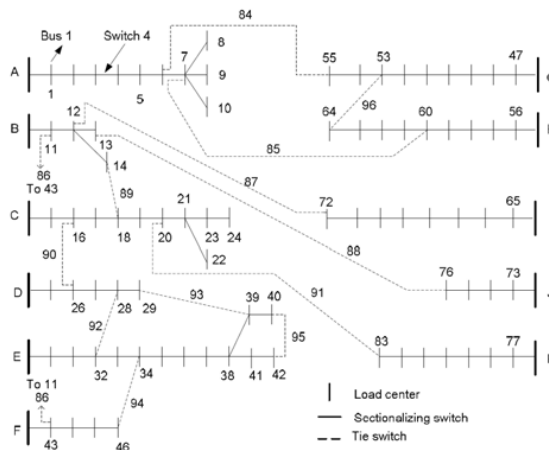

Fig. 6 A distribution system of Taiwan Power Company

**VI. CONCLUSIONS**

In this paper, a new multi-objective function for reducing the total energy supply cost and power losses for deregulated distribution network proposed. The method was applied on a sample and a practical distribution network. The obtained results show that the proposed method could investigate the optimal configuration among various possible configurations and reduced the total energy supply cost with adaptive mutation.

**VII. MATHEMATICAL SYMBOLS**

$i$	Number of substation feeders
$k$	Number of loads at feeder $i$
$EP_i$	Energy price at substation $i$ (\$/MWh)
$P_{lk}$	Losses at each feeder
$P_k(t)$	Instantaneous power of consumer $k$
$P_k$	Average power of consumer $k$
$P_{initial}$	Initial mutation
$P_{final}$	Final mutation
$P_{step}$	Step of mutation variation
$p(k)$	Adaptive mutation
$V_{min}$	Minimum voltage
$V_{max}$	Maximum voltage
$I_k$	Consumer current
$I_{max}$	Maximum current

**REFERENCES**

- [1] M. Arias-Albornoz; H. Sanhueza-Hardy; "Distribution network configuration for minimum energy supply cost," *IEEE Trans. on Power System*, vol. 19, pp. 538-542, 2004.
- [2] S. Civanlar, J. J. Grainger, H. Yin, S. S. H. Lee, "Distribution feeder reconfiguration for loss reduction," *IEEE Trans. on Power Delivery*, vol. 3, pp. 1217-1223, 1988.
- [3] E. Carpaneto, G. Chicco, "Ant-colony search-based minimum losses reconfiguration of distribution systems," in *Proceedings of the 12th IEEE Mediterranean, MELECON*, 2004, pp. 971-974.
- [4] Y. Hong; S. Ho; "Genetic algorithm based network reconfiguration for loss minimization in distribution systems," in *Power Engineering Society General Meeting, USA*, 2003, pp. 13-17.
- [5] D. Shirmohamadi, "Service restoration in distribution network via network reconfiguration," *IEEE Trans. on Power Delivery*, vol. 7, pp. 952-958, 1992.

- [6] K. N. Miu, H. D. Chiang and R. J. McNulty, Multi-Tier, "Service restoration through network reconfiguration and capacitor control for large scale radial distribution networks," *IEEE Trans. on Power System*, vol. 15, pp. 1001-1007, 2000.
- [7] Y. Bin; W. Xiu-li; B. Zhao-hong; W. Xi-fan; "Distribution network reconfiguration for reliability worth enhancement, International Conference on Power System Technology," in *Conf. PowerCon*, 2002, pp. 2547-2550.
- [8] R.F. Chang, C.N. Lu; "Feeder reconfiguration for load factor improvement," in *Power Engineering Society Winter Meeting*, 2002, pp. 980 - 984.
- [9] Yu-Lung Ke; Chao-Shun Chen; Meei-Song Kang; Jaw-Shyang Wu; Tsung-En Lee; Power distribution system switching operation scheduling for load balancing by using colored Petri nets, *IEEE Transactions on Power Systems*, 19 (2004) 629-635.
- [10] K. Nara, A. Shiose, M. Kitagawa, T. Ishihara, "Implementation of genetic algorithm for distribution systems loss minimum reconfiguration," *IEEE Trans. on Power Systems*, vol. 7, pp. 1044-1051, 1992.
- [11] W.M. Lin, F.S. Cheng, M.T. Tsay, "Distribution feeder reconfiguration with refined genetic algorithm," *IEE Proc. Gen. Transmission and Distribution*, vol. 147, pp. 349-354, 2000.
- [12] S.K. Goswami, S.K. Basu, "A new algorithm for the reconfiguration of distribution feeders for loss minimization," *IEEE Trans. on Power Delivery*, vol. 7, pp. 1484-1491, 1992.
- [13] D. Shirmohammadi, H.W. Hong, "Reconfiguration of electric distribution networks for resistive line loss reduction," *IEEE Trans. on Power Delivery*, vol. 4, pp. 1492-1498, 1989.
- [14] T.P. Wagner, A.Y. Chikhani, R. Hackam, "Feeder reconfiguration for loss reduction: an application of distribution automation," *IEEE Trans. on Power Delivery*, vol. 6, pp. 1922-1931, 1991.
- [15] H.C. Cheng, C.C. Kou, "Network reconfiguration in distribution systems using simulated annealing," *Electric Power System Research*, vol. 29, pp. 227-238, 1991.
- [16] H.D. Chiang, J.J. Rene, "Optimal network reconfiguration in distribution systems. Part 1. a new formulation and a solution methodology," *IEEE Trans. on Power Delivery*, vol. 5, pp. 1902-1908, 1990.
- [17] H.D. Chiang, J.J. Rene, "Optimal network reconfiguration in distribution systems. Part 2. Solution algorithms and numerical results," *IEEE Trans. on Power Delivery*, vol. 5, pp. 1568-1574, 1992.
- [18] M. Shahidepour, H. Yamin, Z. Li, *Market operation in electric power systems, Market Overview in Electric Power Systems*, John Wiley & Sons, Inc.2002
- [19] J. Z. Zhu, "Optimal reconfiguration of electrical distribution network using the refined genetic algorithm," *Electric Power Systems Research*, vol. 62, pp. 371-386, 2002.
- [20] B. P. Liu Jain, Z. Wenyuang, "Convergence of branch current based distribution power flow method," *Journal of Xi'an Jiaotong University*, vol. 35, pp. 343-346, 2001.

TABLE I  
DATA OF THE THREE-FEEDER DISTRIBUTION SYSTEM

Bus to Bus	Section Resistance (P.U.)	Section Reactance (P.U.)	End Bus Load (MW)	End Bus Load (MVAR)	End Bus Fixed Capacitor (MVAR)
1-4	0.075	0.1	2.0	1.6	0.0
4-5	0.08	0.11	3.0	1.5	1.1
4-6	0.09	0.18	2.0	0.8	1.2
6-7	0.04	0.04	1.5	1.2	0.0
2-8	0.11	0.11	4.0	2.7	0.0
8-9	0.08	0.11	5.0	3.0	1.2
8-10	0.11	0.11	1.0	0.9	0.0
9-11	0.11	0.11	0.6	0.1	0.6
9-12	0.08	0.11	4.5	2.0	3.7
3-13	0.11	0.11	1.0	0.9	0.0
13-14	0.09	0.12	1.0	0.7	1.8
13-15	0.11	0.11	1.0	0.9	0.0
15-16	0.04	0.04	2.1	1.0	1.8
5-11	0.04	0.04	0	0	0
10-14	0.04	0.04	0	0	0
7-16	0.12	0.12	0	0	0

TABLE II  
THE OTHER PARAMETERS OF THE PROPOSED METHOD

CASE	CASE STUDY I
LENGTH OF CHROMOSOME	16
POPULATION SIZE	10
CROSSOVER PROBABILITY (PM)	0.7
MUTATION PROBABILITY (PC)	ADAPTIVE
NUMBER OF ITERATION	70

TABLE III  
COMPARATIVE NUMERICAL RESULTS OF EXAMPLE I

CASE	OPEN SWITCHES	VOLTAGE OF BUSES		POWER LOSS (P.U)	TOTAL ENERGY SUPPLY COST (\$)
		V <sub>MIN</sub>	BUS		
C1	17,19,26	0.972	12	0.00466	8016.62
C2	13,17,19	0.972	12	0.00479	8012.78

TABLE IV  
DETAILS OF ENERGY SUPPLY COST CALCULATION FOR BEST CONFIGURATION (C3) OF EXAMPLE I

NUMBER OF FEEDERS	1	2	3
LOSS OF FEEDER (MW)	0.05968	0.31708	0.10252
LOADS OF FEEDER (MW)	7.6	13.5	7.6
ENERGY PRICE IN FEEDER (\$/MWH)	11.4	11.6	11.2
ENERGY SUPPLY COST IN FEEDER (\$)	2095.68	3846.67	2070.43
SYSTEM TOTAL ENERGY SUPPLY COST (\$) = 2095.68 + 3846.67 + 2070.43 = 8012.78			

TABLE V  
DATA OF TAIWAN POWER COMPANY

BUS TO BUS	SECTION R ( )	SECTION X ( )	END BUS LOAD (KW)	END BUS LOAD (KVAR)	BUS TO BUS	SECTION R ( )	SECTION X ( )	END BUS LOAD (KW)	END BUS LOAD (KVAR)
A-1	0.1944	0.6624	0	0	G-47	0.2430	0.8280	0	0
1-2	0.2096	0.4304	100	50	47-48	0.0655	0.1345	0	0
2-3	0.2358	0.4842	300	200	48-49	0.0655	0.1345	0	0
3-4	0.0917	0.1883	350	250	49-50	0.0393	0.0807	200	160
4-5	0.2096	0.4304	220	100	50-51	0.0786	0.1614	800	600
5-6	0.0393	0.0807	1100	800	51-52	0.0393	0.0807	500	300
6-7	0.0405	0.1380	400	320	52-53	0.0786	0.1614	500	350
7-8	0.1048	0.2152	300	200	53-54	0.0524	0.1076	500	300
7-9	0.2358	0.4842	300	230	54-55	0.1310	0.2690	200	80
7-10	0.1048	0.2152	300	260	H-56	0.2268	0.7728	0	0
B-11	0.0786	0.1614	0	0	56-57	0.5371	1.1029	30	20
11-12	0.3406	0.6944	1200	800	57-58	0.0524	0.1076	600	420
12-13	0.0262	0.0538	800	600	58-59	0.0405	0.1380	0	0
12-14	0.0786	0.1614	700	500	59-60	0.0393	0.0807	20	10
C-15	0.1134	0.3864	0	0	60-61	0.0262	0.0538	20	10
15-16	0.0524	0.1076	300	150	61-62	0.1048	0.2152	200	130
16-17	0.0524	0.1076	500	350	62-63	0.2358	0.4842	300	240
17-18	0.1572	0.3228	700	400	63-64	0.0243	0.0828	300	200
18-19	0.0393	0.0807	1200	1000	I-65	0.0486	0.1656	0	0
19-20	0.1703	0.3497	300	300	65-66	0.1703	0.3497	50	30
20-21	0.2358	0.4842	400	350	66-67	0.1213	0.4140	0	0
21-22	0.1572	0.3228	50	20	67-68	0.2187	0.7452	400	360
21-23	0.1965	0.4035	50	20	68-69	0.0480	0.1656	0	0
23-24	0.1310	0.2690	50	10	69-70	0.0729	0.2484	0	0
D-25	0.0567	0.1932	50	30	70-71	0.0567	0.1932	200	1500
25-26	0.1048	0.2152	100	60	71-72	0.0262	0.0528	200	0
26-27	0.2489	0.5111	100	70	J-73	0.3240	1.1040	0	0
27-28	0.0489	0.1650	1800	1300	73-74	0.0324	0.1104	0	150
28-29	0.1310	0.2690	200	120	74-75	0.0567	0.1932	1200	950
E-30	0.1965	0.3960	0	0	75-76	0.0486	0.1656	300	180
30-31	0.1310	0.2690	1800	1600	K-77	0.2511	0.8556	0	0
31-32	0.1310	0.2690	200	150	77-78	0.1296	0.4416	400	360
32-33	0.0262	0.0538	200	100	78-79	0.0486	0.1656	2000	1300
33-34	0.1703	0.3497	800	600	79-80	0.1310	0.2640	200	140
34-35	0.0524	0.1076	100	60	80-81	0.1310	0.2640	500	360
35-36	0.4978	1.0222	100	60	81-82	0.0917	0.1883	100	30
36-37	0.0393	0.0807	20	10	82-83	0.3144	0.6436	400	360
37-38	0.0393	0.0807	20	10	5-55	0.1310	0.2690		
38-39	0.0786	0.1614	20	10	7-60	0.1310	0.2690		
39-40	0.2096	0.4304	20	10	11-43	0.1310	0.2690		
38-41	0.1965	0.4035	200	160	12-72	0.3406	0.6994		
41-42	0.2096	0.4304	50	30	13-76	0.4585	0.9415		
F-43	0.0486	0.1656	0	0	14-18	0.5371	1.0824		
43-44	0.0393	0.0807	30	20	16-26	0.0917	0.1883		
44-45	0.1310	0.2690	800	700	20-83	0.0786	0.1614		
45-46	0.2358	0.4842	200	150	28-32	0.0524	0.1076		
					29-39	0.0786	0.1614		
					34-46	0.0262	0.0538		
					40-42	0.1965	0.4035		
					53-64	0.0393	0.0807		

TABLE VI  
THE PARAMETER OF THE PROPOSED METHOD FOR CASE STUDY 2

CASE	EXAMPLE II
LENGTH OF CHROMOSOME	96
POPULATION SIZE	60
CROSSOVER PROBABILITY (PM)	0.7
MUTATION PROBABILITY (PC)	ADAPTIVE
NUMBER OF ITERATION	690

TABLE VII  
DETAILS OF ENERGY SUPPLY COST CALCULATION FOR BEST CONFIGURATION (C2) OF EXAMPLE II

FEEDING SUBSTATION NUMBER	LOSS OF FEEDER (KW)	LOADS OF FEEDER (KW)	ENERGY PRICE IN FEEDER (\$/MWH)	ENERGY SUPPLY COST IN FEEDER (US\$)
A	48.05	2270	11.1	617.5
B	53.28	3200	10.9	851.1
C	75.03	4050	11	1089
D	49.66	3080	10.8	811.208
E	15	1800	11.9	518.36
F	14.046	1930	11	513.23
G	61.822	3100	11.9	903.02
H	56.093	2170	10.5	560.98
I	53.561	2450	11.4	684.97
J	7.66	1200	11.3	327.52
K	50.436	3100	11.2	846.84
System Total Energy Supply Cost (\$) = 7723.7				

TABLE VIII  
COMPARATIVE NUMERICAL RESULTS OF EXAMPLE II

CASE		OPEN SWITCHES	VOLTAGE OF BUSES		POWER LOSS (MW)	TOTAL ENERGY SUPPLY COST (\$)
			V <sub>MIN</sub>	BUS		
C1	UN-DEREGULATED SYSTEMS WITH ONLY LOSSES MINIMIZATION	55, 7, 86, 72, 13, 89, 90, 83, 92, 39, 34, 42, 62	0.9532	71	0.46985	7750.6
C2	DEREGULATED SYSTEMS WITH ENERGY SUPPLY COST MINIMIZATION	55, 7, 63, 86, 72, 76, 89, 90, 82, 42, 32, 34, 36	0.9517	9	0.48464	7723.7