

# Realization of Autonomous Guidance Service by Integrating Information from NFC and MEMS

Dawei Cai

**Abstract**—In this paper, we present an autonomous guidance service by combining the position information from NFC and the orientation information from a 6 axis acceleration and terrestrial magnetism sensor. We developed an algorithm to calculate the device orientation based on the data from acceleration and terrestrial magnetism sensor. If visitors want to know some explanation about an exhibit in front of him, what he has to do is just lift up his mobile device. The identification program will automatically identify the status based on the information from NFC and MEMS, and start playing explanation content for him. This service may be convenient for old people or disables or children.

**Keywords**—NFC, Ubiquitous Computing, Guide System, MEMS.

## I. INTRODUCTION

MUSEUM visitors' guides systems [1], [4], [5] with ICT have recently been attracting a growing interest and firing more research efforts and business activities, but many museums presents their exhibits in a rather passive and non-engaging way. The visitors have to scan a booklet in order to find some general information about the object. However, searching for information about object after object is quite tedious and the information found does not always cover the visitor's specific interests. One possibility of making exhibitions more attractive to the visitors is to provide information based on their needs, to improve their interaction with the guidance.

There are several museum guidance system with general smart phone or digital device such as iPad, iPodtouch, or portable game player such as Nintiandao 3D. Most of them can provide a multimedia guidance, but several problems may block their wide usages. For example, the huge multimedia contents will be downloaded to the phone through network, but it will be cost a lot for foreign tourists. The guidance cannot be provided to the visitors who do not have the phone or the device. Another problem is traffic trouble if many visitors access the same contents at the same time. Therefore, a cheap and specialized device for the museum is necessary for most cases. Recently, NFC and MEMS techniques are paid much attention for mobile device service, more and more devices are mounted with NFC and MEMS.

For some museums with large or complex exhibition areas, it may be important to provide an automatic guidance without any button operations from visitors. This function may be more useful for elders or younger children for they are hard to operate button or hard to know how to use them.

GPS is commonly used for locating a position, but it is only available for outside area and also has some problems

Dr. D. Cai is with the Department of Software and Information Engineering, Iwate Prefectural University, Iwate, 020-0197 Japan (e-mail:ai@iwate-pu.ac.jp).

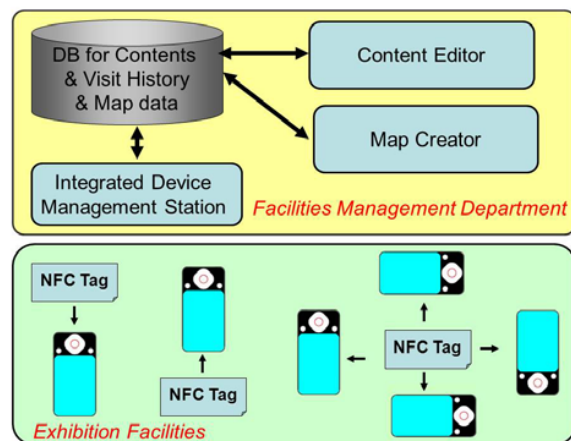

Fig. 1 The basic architecture of the guide system

for accuracy. Another technique based on WLAN can be available in room, but also have a problem of accuracy.

We have developed an multimedia device for interactive guidance [2], [3]. In this paper, we propose an approach to identify orientation and position of mobile devices by combining the position information from NFC and the orientation information from a 6 axis acceleration and terrestrial magnetism sensor. With the orientation and position information, we can guess the visitors' position and their orientation, and give an automatic guidance service for the exhibition object just in front of them.

## II. AUTOMATIC GUIDANCE SYSTEM

### A. Generic Structure

Fig.1 shows the main configuration of the new guide system. As shown in Fig.1, there are a sub system for management department and a sub system for visitors in exhibition area. The first sub system will provide main management functions for exhibition facilities, such as, content editing for guidance, map creating module that will provide the position and orientation information about the exhibition objects, guide mobile device management including content installation and deletion, the mobile device working mode setting up, visiting history anglicizing and statistics. The second sub system will automatically provide guidance of exhibits.

In first sub system, we developed an Integrated Device Management Station that can send contents and map data and setting data to the device and get visiting history data from

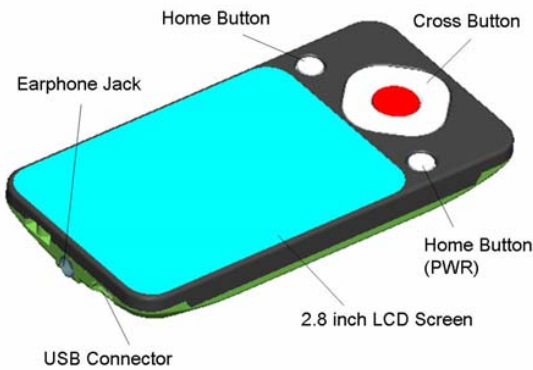

Fig. 2 New Portable Guide Device

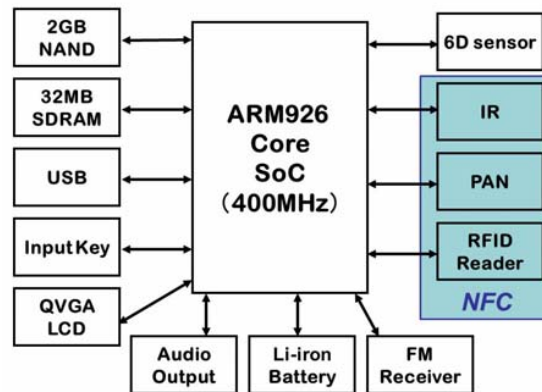

Fig. 3 The Architecture of portable Device

the device with a hybrid wireless communication that use both infrared communication and a radio communication called PAN. Easy to use contents editor software is also developed for creating contents for ones who know the basic operation of personal computer. To realize the automatic guidance service based on the status of the visitors, a map data for exhibition area including the position and orientation information of exhibits and the position of the NFC tags is necessary. A map making software is designed to realize the above functions.

In second sub system, we developed an portable guide device, which have NFC ability to get ID information from NFC tags such as IR (infrared) tag, RFID tag or PAN (personal area network) tag, and get or send data with the Integrated Device Management Station. The device can obtain the position information from ID based on a map data. For there is a 6 axis acceleration and terrestrial magnetism sensor, we can know the device orientation based on the information from MEMS sensor. If Mutual position between the device and user is fixed or constrained, we can presume the situation of the visitor easily.

### B. Portable Guide Device

The new portable guide device provides NFC, such as instant infrared communication, RFID reader, IR receiver, PAN, also can play multimedia contents, such as multi-language text, image, audio, and video. There are a cross-key and two additional keys for switching the contents playing or inputting the answers of the quits. In the device we board a 6 axis acceleration and terrestrial magnetism sensor IC to obtain the information about the device orientation and attitude condition. With the NFC and a new identification algorithm, the portable device can identify the status of the visitors and start playing the related content automatically without any operation by users; therefore the device can be used by a wide range visitor from children to elder persons. Fig.2 shows the main parts of the portable device.

The new portable device is developed with an ARM926



Fig. 4 The Appearance of Portable Device

core SoC and a RTOS platform called ThreadX. Fig.3 shows the main structure of the portable device. As shown in Fig.3, the portable device is composed with a ARM926 core SoC, 6 degrees sensor IC, ubiquitous communication IC, a flash memory, a MDDR, a 2.8 inch LCD with 0.26M color and audio output with both earphone and a mini speaker. A 650mAh Li-iron battery is used to provide the power to guarantee the device can work more than 8 hours without charging. Compared with other wireless communication such as WLAN, Bluetooth, the infrared communication and PAN radio communication can reduce the power consumption greatly, therefore, the new portable terminal can provide a much longer operation time. For a guide system in exhibition facilities, it is important that the portable device can provide guidance service without recharging during the whole opening period.

### III. ALGORITHM FOR POSITION AND ORIENTATION

#### A. Formulation of Device Orientation

It may be a complex calculation for arbitrary situation device. In this guide service, we will give a condition for the situation of the device. This condition is used as a sign for starting explanation from the visitor. The constraint condition is that the visitor should hold the device straightly. For derivation of the calculation formulation, we will define two coordinates as shown in Fig.5. There are two coordinates defined,  $OXYZ$  and  $Oxyz$ .  $OXYZ$  is fixed to ground and its  $X$  axis points to the North Pole, and  $-Z$  follows the gravity direction. Note the axis  $X$  is not true north direction, there is a little difference between the North Pole and true north. The difference value can be compensated based on the latitude.  $Oxyz$  is fixed to the device as shown in Fig.5.  $\Theta$  is the inclination angle of the device, and  $\alpha$  is the orientation of the device.  $a_x$ ,  $a_y$  and  $a_z$  are the acceleration sensor outputs on each axis.  $M_x$ ,  $M_y$  and  $M_z$  are the terrestrial magnetism sensor outputs on each axis.

Because we have a constraint condition as a sign for starting guidance, the plane  $XOY$  and  $xOy$  are at the same plane. This condition can be shown as

$$a_x = 0 \quad (1)$$

Because we use acceleration output to calculate  $\Theta$ , the inclination of the device, the device should be in a still mode. To guarantee the condition, we will check if

$$a_x^2 + a_y^2 + a_z^2 - g^2 = 0 \quad (2)$$

is satisfied.

Under the constraint conditions,  $\Theta$  and  $\alpha$  can be calculated from the outputs of acceleration sensor and terrestrial magnetism sensor. When the visitor holds the device without movement, the total acceleration is only gravity acceleration, therefore the  $\Theta$  can be obtained by

$$\Theta = \tan^{-1}\left(\frac{a_y}{a_z}\right) \quad (3)$$

When visitors require guidance service, they will hold the device with a proper tilt angle. Therefore, the tilt angle  $\Theta$  should be at a range

$$0 < \Theta < \pi/2 \quad (4)$$

Then we can calculate the orientation of the device as the followings

$$\alpha = \tan^{-1}\left(\frac{M_y \cos \Theta - M_z \sin \Theta}{M_x}\right) \quad (5)$$

It is easy to obtain the orientation of visitor, if we determine the relative position between the visitor and the device. For the constraint condition mentioned above, the visitor will hold the device in front of him, therefore the orientation of the visitor  $\beta$  can be calculated as

$$\beta = \pi + \alpha \quad (6)$$

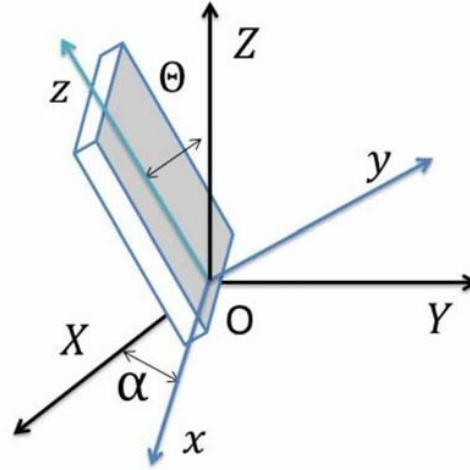

Fig. 5 The coordinates for ground and device

#### B. Identification of the Visitors' Status

With the information from NFC, acceleration sensor and the terrestrial magnetism sensor, we give our algorithm for automatic guidance in Fig.6.

The algorithm gives the general framework for autonomous guidance service. To guarantee enough accuracy, MEMS MEMS initialization is necessary. When a visitor stands before an exhibit and holds the device up, the identification of the orientation will run. When the visitor holds the device straight, the  $x$  axis of the device should be paralleled with the ground. In this case, the  $a_x$  should be zero. In real application, the output  $a_x$  from acceleration sensor may not be exactly zero for electrical noise and little hand vibration. Therefore, we modify the condition as

$$\|a_x\| < \epsilon_1 \quad (7)$$

where positive value  $\epsilon_1 \ll 1$ . Another condition (2) will be modified as

$$\|a_x^2 + a_y^2 + a_z^2 - g^2\| < \epsilon_2 \quad (8)$$

where position value  $\epsilon_2 \ll 1$ .

The value of  $\epsilon_1$  and  $\epsilon_2$  will be determined by some later experiments. Too small values for  $\epsilon_1$  and  $\epsilon_2$  may bring a better accuracy for identification, but may raise the hassle of calculation and make the visitors feeling tired. Therefore, it is important to adjust  $\epsilon_1$  and  $\epsilon_2$  for best performance.

When the condition (7) and (8) are satisfied both, we can start to calculate  $\Theta$ , the inclination angle of the device by (3). If the inclination angle  $\Theta$  satisfies the condition (4), it means that the device is in a good attitude for guidance service. Therefore, we can calculate the orientation of the device by (5). Finally, we will obtain the orientation of the visitor by (6) and check the map DB to find if there is exhibit guidance for this orientation and position. The device will start to play the multimedia guidance content, if there is a record in the map DB for current orientation and position.

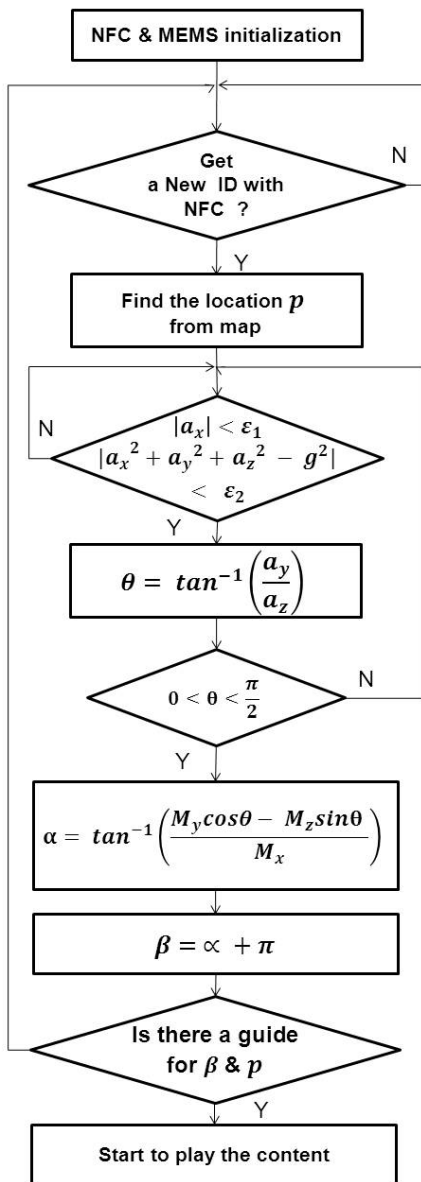

Fig. 6 The algorithm for identifying orientation

#### IV. CONCLUSIONS

In this paper, we present an autonomous guidance service by combining the position information from NFC and the orientation information from a 6 axis acceleration and terrestrial magnetism sensor. To realize the service, a new mobile device is designed and developed with NFC and MEMS installed. The device can get location related information from NFC, and orientation related information from acceleration and terrestrial magnetism MEMS, but also can show a multimedia guidance content. We developed an algorithm to calculate the device orientation based on the data from

acceleration and terrestrial magnetism MEMS sensor. With the position and orientation information, it is possible to provide an autonomous guidance to visitors especially who are older people. The original acceleration and terrestrial magnetism data are sampled successfully with a good accuracy. With the experiment, the acceleration data is accuracy for identifying the orientation, but the terrestrial magnetism data need calibration and compensation. We will give a report about the orientation identification.

#### REFERENCES

- [1] Kusunoki, F.; Sugimoto, M.; Hashizume, H. *Toward an interactive museum guide system with sensing and wireless network technologies*, Wireless and Mobile Technologies in Education, 2002. Proceedings. IEEE International Workshop on Volume , Issue , Page(s): 99-102, 2002.
- [2] Dawei Cai, Ryuuta Kawashima, Tadaaki Takehana and Haruki Takahashi *An Infrared Digital Contents Broadcasting Service for Mobiles*, WSEAS Trans. on Communication, Vol.2(4), 73-78, 2005.
- [3] Dawei Cai, Yuji Saito and Yoshihiko Abe, *An Information Broadcasting System with Infrared data Communication Protocol*, WSEAS Trans. on Communication, Vol.2(3), 228-234, 2003.
- [4] Li-Der Chou; Chia-Hsieh Wu; Shih-Pang Ho; Chen-Chow Lee; Jui-Ming Chen, *Requirement analysis and implementation of palm-based multimedia museum guide systems*, Advanced Information Networking and Applications, 2004. AINA 2004. 18th International Conference on Volume 1, Issue , 2004 Page(s): 352 - 357 Vol.1.
- [5] Bartneck, C., Masuoka, A., Takahashi, T., Fukaya, T. *An Electronic Museum Guide in Real Use*, Psychology of Aesthetics, Creativity, and the Arts, 1(2), 114-120, 2007.