

Real Time Monitoring of Long Slender Shaft by Distributed-Lumped Modeling Techniques

Sina Babadi, K. M. Ebrahimi

Abstract—The aim of this paper is to determine the stress levels at the end of a long slender shaft such as a drilling assembly used in the oil or gas industry using a mathematical model in real-time. The torsional deflection experienced by this type of drilling shaft (about 4 KM length and 20 cm diameter hollow shaft with a thickness of 1 cm) can only be determined using a distributed modeling technique. The main objective of this project is to calculate angular velocity and torque at the end of the shaft by TLM method and also analyzing of the behavior of the system by transient response. The obtained result is compared with lumped modeling technique the importance of these results will be evident only after the mentioned comparison. Two systems have different transient responses and in this project because of the length of the shaft transient response is very important.

Keywords—Distributed Lumped modeling, Lumped modeling, Drill string, Angular Velocity, Torque.

I. INTRODUCTION

DRILLS used in oil/gas industry are good examples of long slender shafts where the ratio of shaft's length to its diameter is very large. In Oil/gas well drilling the drill strings transmits torque to the drill bit for cutting the wells. Drill shaft failure (due to torsional stress), friction, vibration and risk of the operation are increased as the drill string length increases. Stress level monitoring during drilling operations increases the efficiency of the drilling and it is the most effective methods to prevent threat of the drill failure [8]. Most of the existing stress / torque monitoring system use sensors to provide information from down hole during drilling. This information is transferred to the surface and after being analysed and processed it enables engineers to control system. The use of sensors is very costly and existing modelling tools such as finite element technique are computationally very slow for real-time prediction. On the other hand the lumped modelling techniques are too simplistic to give an accurate prediction of the load torque at the other end of the shaft. Using mathematical modelling technique a virtual sensor can be developed. Distributed lumped modelling technique can be employed to predict the stress level at the load end of the shaft accurately. In this paper, the distributed lumped modelling technique which has been extended to mechanical systems modelling is adapted to the drill string modelling by measuring angular velocity and torque at end of the drill string. And also a comparison of the simulation of the distributed lumped modelling and lumped modelling are presented.

S. Babadi was with the Electrical Engineering Department, University of Bradford. (Phone:+44 (0)770 91 89 655, e-mail: sibabadi@yahoo.com).

M. K. Ebrahimi Director of HYBERC Mechanical Department, University of Bradford, (e-mail:m.ebrahimi@bradford.ac.uk).

Drill pipe, drill collar and bits are three main components of drilling system. The length of drill pipe even has been reached to eight kilometres; Drill bits are contiguous at the end of the drill pipe to drill ground. Drill collars are installed a little above of the drill bit to provide proper weight to increase efficiency of drilling. Weight of the drill collar is variable but maximum range of the weight of drill collar is 2500 kilograms.

Measurement while drilling (MWD) [10]; is a general name to monitor the conditions during drilling. MWD has various types of methods to monitor the condition of the well down stream. Many of the methods are mathematical (theory) correlation, while others utilize tools (practical) or may be a combination of both systems (theory and practical).

Ordinary differential equation and partial differential equation are main difference in mathematical presentation between lumped modelling and distributed- lumped modelling. "All systems are distributed in the nature" but for modelling they can be presented by ordinary differential equation or mixture of distributed and lumped model. The distinction between two models for presentation of which is suitable for purpose transient response of a system can be difficult [12]. Have mentioned distributed lumped model must be considered if the transient response of the system was to be strongly regulated the other hand if transient response was not critical in that case lumped model might be suitable.

II. LUMPED MODELLING OF DRILL PIPE

Drilling system can be divided into three components: 1) Prime mover on the surface which produces all the torque to drill, 2) Drilling pipe which is hollow shaft and it consist of plenty of the pipe section which screw one to each other, 3) Bottom Hole Assembly (BHA) which consists of drill collar, Drill bits, shock sub and etc. Figure 1 shows simple model of connection of the motor to bits by drill string. It is a simplified model of drill pipe. It consists of two elements: 1) the drill pipe (J_r), 2) the drill collars and drill bits both together (J_b). The inertias are coupled one to each other by linear spring with torsional spring (K) and torsional damping (c). Table 1 describes the symbols which have been used for this paper.

TABLE I
NOMENCLATURE

Symbol	Quantity	MKS Dimension
L	Inductance	[H]
C	Capacitance	[F]
R	Resistance	Ω
Z^{-1}	Delay Time	[S]
V	Voltage	[V]
I	Current	[A]
G	Modulus of rigidity	[G]
L	Length	[m]

P	Pressure	[pa]
K	Stiffness	[N.m/rad]
C	Bearing Damping	[Nms/rad]
ρ	Density	[Kg/m ³]
ϕ	Displacement	[rad]
$\dot{\phi}$	Angular Velocity	[rad/s]

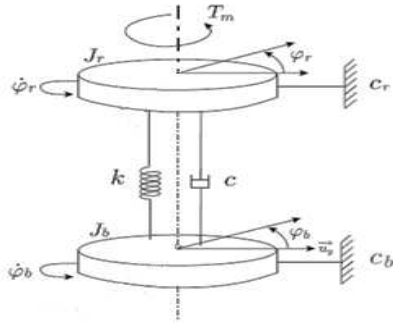

Fig. 1 Mechanical model describing the torsional behavior of a generic drill string

$$T_m = (J_r s + C_r) \dot{\phi}_r + c(\dot{\phi}_r - \dot{\phi}_b) + k(\phi_r - \phi_b) \quad (1)$$

$$k(\phi_r - \phi_b) + C_r(\dot{\phi}_r - \dot{\phi}_b) = J_b \ddot{\phi}_b + C_b \dot{\phi}_b$$

T_m is the torque which is provided by prime mover with $\phi_i, \dot{\phi}_i$ the angular displacement and angular velocities of drilling elements [1].

Therefore for finding $\dot{\phi}_b$ or ω_1 (angular velocity at the end of the shaft)

$$\omega_1 = \dot{\phi}_b = \frac{(cs + K)}{(L_1 S^3 + L_2 S^2 + L_3 S + L_4)} T_m \quad (2)$$

Where

$$L_1 = J_r J_b$$

$$L_2 = (J_r C_b + J_b C_r + J_b c + J_r c)$$

$$L_3 = (J_r K + J_b K + C_b c + C_r c + C_b C_r)$$

$$L_4 = (C_b + C_r) K$$

And also to find $\dot{\phi}_r$ or ω_o (angular velocity at the beginning of the shaft)

$$\omega_o = \dot{\phi}_r = \frac{J_b S^2 + (C_b + c)S + K}{L_1 S^3 + L_2 S^2 + L_3 S + L_4} T_m \quad (3)$$

Figure 2 depicts the angular velocities of the drill string at beginning and at end of the shaft by lumped modelling technique correspond to real drill string design with 4000 meters of the length of the shaft, 7.5 centimeters of the inner radius, 8.41 centimeters of the outer radius and 79.6×10^9 (G) for shear modulus. The other model parameters used for the simulation are:

$$J_r = 930 \text{kgm}^2, J_b = 1570 \text{kgm}^2, k = 580 \text{Nm/rad},$$

$$C_r = 200 \text{Nms/rad}, C_b = 200 \text{Nms/rad}, T_m = 7000 \text{Nm},$$

$$c = 200 \text{Nms/rad}$$

III. STICK SLIP

Stick-slip takes place when parts of the whirling drill pipe are caught by friction in contrast to the borehole and then release [3]. It can be sufficient to stop completely the rotation at the bit. After releasing, the speed of the rotation of the collars is increased dramatically and makes massive centrifugal acceleration [6]. Increasing torque, decreasing weight on bit and increasing cutting surface are three methods to reduce stick-slip [9][11]. Stick-slip makes fatigue system and risk of operation has been increased by this event. In this model increasing torque has been proposed to eliminate stick-slip. By above model, stick-slip phenomena have been modelled in MATLAB Simulink.

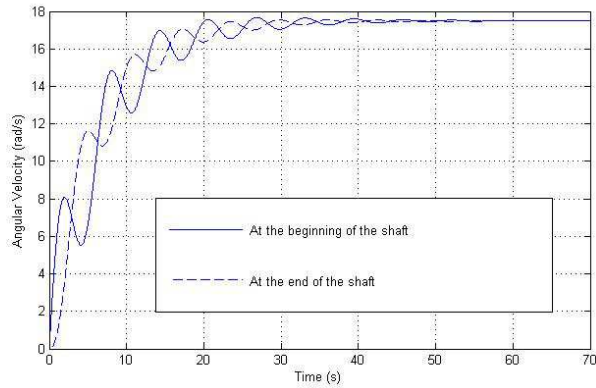

Fig. 2 Angular velocity in the beginning at the end of the drill pipe

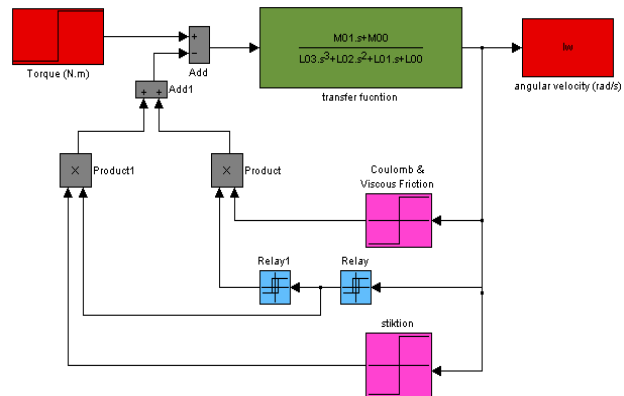

Fig. 3 Simulation in MATLAB Simulink for Stick-Slip modeling

Figure 3 is a simple simulation of stick-slip phenomena by MATLAB simulation, which relays act as switch. According figure 4 describes above model appropriately stick-slip oscillation. Angular velocity oscillates between zero to 0.8 (rad/s). Figure 4 depicts that a huge oscillation has been generated by friction between wellbore and drill string, coulomb and viscous friction and sticktion is used to model of friction of the wellbore and drill pipe. This oscillation has been eliminated completely by increasing torque (Figure 5).

IV. DISTRIBUTED LUMPED MODELING OF DRILL PIPE

In this section, an alternative model for calculating torque

and angular velocity is proposed. Transmission Line Modelling (TLM) has been used for calculating voltage and current in an electrical circuit. Transmission line has been divided into small sections by this method to calculate voltage and current precisely (figure 6). Then this technique has been extended to other physical system such as wave propagation and etc.

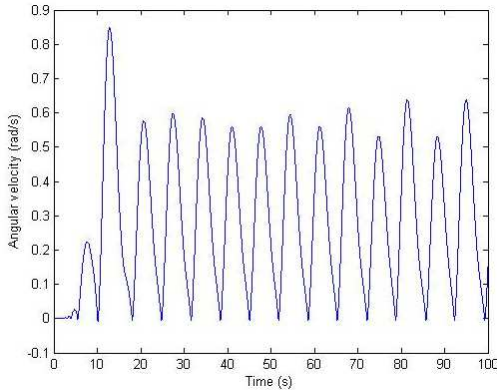

Fig. 4 Angular velocity of drill bit during stick-slip phenomena

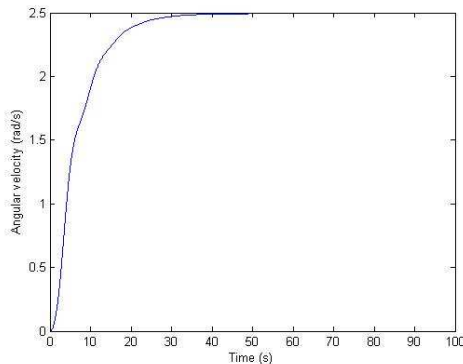

Fig. 5 Angular velocity after increasing torque to 9000 N.m

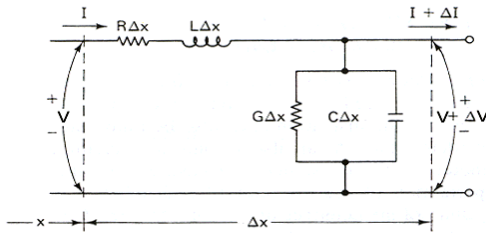

Fig. 6 A TLM model for a section of transmission line

This method has been used in other phenomena by substituting other elements into electrical elements. TLM is directly related to a time-delay method, in its elementary form a rotary shaft is treated as set of the pipes. In this case, Simple rotary shaft, shaft was divided into small segments. Torque (T) and angular velocity (ω) are input of the system or drill pipe and also other torque and angular velocity are output of this part [2,4,5].

The difference of the voltage and current can be calculated by Kirchhoff's voltage and current law.

$$v(t, x + \Delta x) - v(t, x) = -\left[L \left(\frac{\partial i(t, x)}{\partial t} \right) + Ri(t, x) \right] \Delta x \quad (4)$$

Taking limit from Δx approach to zero and dividing by Δx

$$\frac{\partial v(t, x)}{\partial x} = -\left[L \left(\frac{\partial i(t, x)}{\partial t} \right) + Ri(t, x) \right]$$

Also for current:

$$i(t, x + \Delta x) - i(t, x) = -\left[C \left(\frac{\partial v(t, x)}{\partial t} \right) + Gv(t, x) \right] \Delta x \quad (5)$$

Taking limit from Δx approach to zero and dividing by Δx

$$\frac{\partial i(t, x)}{\partial x} = -\left[C \left(\frac{\partial v(t, x)}{\partial t} \right) + Gv(t, x) \right]$$

$$\frac{dV}{dx} = -(Ls + R) I \quad (6)$$

$$\frac{dI}{dx} = -(Cs + G) V \quad (7)$$

$$\frac{d^2 V}{dx^2} - [(Ls + R)(Cs + G)] V = 0 \quad (8)$$

$$\frac{d^2 I}{dx^2} - [(Ls + R)(Cs + G)] I = 0 \quad (9)$$

Equations (8) and (9) are special relation for distributed-lumped model just for electrical transmission line. But these equations can be used for other phenomena having similar structures to transmission line by substituting current and voltage with general input and output such as u_j and y_j respectively [2]. In general state, series inductance and shunt capacitance are inertia and compliance of the system and series resistance and shunt conductance, for example in fluid system, are representing the fluid friction resistance and fluid strain. Therefore, the equations 10, 11 are general form of the equations 8, 9 [4],[5].

$$\frac{d^2 u_j}{dx^2}(x, s) = [(L_j s + R_{0j})(C_j s + G_{0j})] u_{j(x, s)} \quad (10)$$

$$\frac{d^2 y_j}{dx^2}(x, s) = [(L_j s + R_{0j})(C_j s + G_{0j})] y_{j(x, s)} \quad (11)$$

With assumption $\Gamma_j^2 = [(L_j s + R_{0j})(C_j s + G_{0j})]$

$$\frac{d^2 u_j}{dx^2}(x, s) - \Gamma_j^2 u_{j(x,s)} = 0$$

$$\frac{d^2 y_j}{dx^2}(x, s) - \Gamma_j^2 y_{j(x,s)} = 0$$

R_{0j} and G_{0j} have no important role in some event therefore it can be negligible. For example, in rotating shafts for a torsional can be negligible but for hydraulic fluid system R_{0j} should be included.

$$\begin{bmatrix} u_j(s) \\ u_{j+1}(s) \end{bmatrix} = \begin{bmatrix} \xi_j \operatorname{ctnh} \Gamma_j l_j & -\xi_j \operatorname{csch} \Gamma_j l_j \\ \xi_j \operatorname{csc} h \Gamma_j l_j & -\xi_j \operatorname{ctnh} \Gamma_j l_j \end{bmatrix} \begin{bmatrix} y_j(s) \\ y_{j+1}(s) \end{bmatrix} \quad (12)$$

Where

$$\xi_j = \sqrt{\frac{L_j}{C_j}}, \beta_j = e^{2l_j b \sqrt{L_j C_j}}, Z_j = e^{s \left[\frac{T_{Pj}}{2} \right]}$$

$$\operatorname{ctnh} \Gamma_j l_j = \frac{e^{2\Gamma_j l_j} + 1}{e^{2\Gamma_j l_j} - 1}$$

$$\operatorname{ctnh} \Gamma_j l_j = w_j, \operatorname{csch} \Gamma_j l_j = \sqrt{w_j^2 - 1},$$

$$\begin{bmatrix} u_{j(w_j)} \\ u_{j+1}(w_{j+1}) \end{bmatrix} = \begin{bmatrix} \xi_j w_j & -\xi_j (w_j^2 - 1)^5 \\ \xi_j (w_j^2 - 1)^5 & -\xi_j w_j \end{bmatrix} \begin{bmatrix} y_j(w_j) \\ y_{j+1}(w_{j+1}) \end{bmatrix} \quad (13)$$

$$\frac{\partial \omega_j}{\partial x}(x, t) = -L_j \frac{\partial T_j}{\partial t}(x, t)$$

$$\frac{\partial T_j}{\partial x}(x, t) = -C_j \frac{\partial \omega_j}{\partial t}(x, t)$$

L_j And C_j are shaft inertia and compliance per unit of length of the shaft respectively

$$L_j = J_j \rho_j, C_j = \frac{1}{G_j J_j}$$

$$\frac{dT_j}{dx}(x, s) = -s L_j \omega_j(x, s),$$

$$\frac{d\omega_j}{dx}(x, s) = -s C_j T_j(x, s),$$

$$\begin{bmatrix} \omega_j(Z_j^{-1}) \\ \omega_{j+1}(Z_{j+1}^{-1}) \end{bmatrix} = Z_j(z_j^{-1}) \begin{bmatrix} T_j(Z_j^{-1}) \\ T_{j+1}(Z_{j+1}^{-1}) \end{bmatrix} \quad (14)$$

Where

$$Z_j(z_j^{-1}) = \xi_j \begin{bmatrix} \frac{1+z_j^{-1}}{1-z_j^{-1}} & -\frac{2z_j^{-5}}{1-z_j^{-1}} \\ \frac{2z_j^{-5}}{1-z_j^{-1}} & -\frac{1+z_j^{-1}}{1-z_j^{-1}} \end{bmatrix}$$

$$Z_j^{-1} = e^{-2\Gamma_j l_j} = e^{-\frac{T_P}{2}} \quad (16)$$

$$\Gamma_j = S \sqrt{L_j C_j} \text{ or } \Gamma_j = S \sqrt{\frac{\rho_j}{G_j}}$$

$$\xi_j = \sqrt{\frac{L_j}{C_j}} \text{ or } \xi_j = j_j \sqrt{\rho_j G_j}$$

$$\begin{bmatrix} \omega_j(Z_j^{-1}) \\ \omega_{j+1}(Z_{j+1}^{-1}) \end{bmatrix} = \xi_j \begin{bmatrix} \frac{1+z_j^{-1}}{1-z_j^{-1}} & -\frac{2z_j^{-5}}{1-z_j^{-1}} \\ \frac{2z_j^{-5}}{1-z_j^{-1}} & -\frac{1+z_j^{-1}}{1-z_j^{-1}} \end{bmatrix} \begin{bmatrix} T_j(Z_j^{-1}) \\ T_{j+1}(Z_{j+1}^{-1}) \end{bmatrix} \quad (17)$$

Above matrix (17) is general form of the relationship between angular velocity and torque.

$$\frac{\omega_1}{T_1}(z_0) = \frac{1}{J_L} \left[\frac{Z_0}{Z_0 - e^{-aT_{d0}}} \right] \quad (18)$$

$$T_1(s) = (J_L s + D_L) \omega_1(s) \quad (19)$$

$$\frac{\omega_1}{T_1}(s) = \frac{1}{(s+a) J_L} \quad (20)$$

Via taking Z transform of equation

$$\frac{\omega_1}{T_1}(z_0) = \frac{1}{J_L} \left[\frac{Z_0}{Z_0 - e^{-aT_{d0}}} \right] \quad (21)$$

The steady state gain from equation when

$$s \rightarrow 0 \quad \frac{\omega_1}{T_1}(0,0) = \frac{1}{D_L}$$

Hence, equation can be written as $\frac{\omega_1}{T_1}(z_0) = \frac{D_L z_0}{z_0 - \alpha_L}$

Where

$$\beta_L = \frac{1 - \alpha_L}{D_L}, \alpha_L = e^{-\left(\frac{D_L}{J_L}\right) T_{d0}}$$

$$T_1(z_0) = X_L(z_0) \omega_1(z_0)$$

$$X_L(W_0) = \frac{(1 + \alpha_L) + W_0(1 - \alpha_L)}{D_L} \quad (22)$$

$$\begin{bmatrix} T_0(W_0) \\ 0 \end{bmatrix} = \begin{bmatrix} \xi_0 w_0 & -\xi_0 \sqrt{w_0^2 - 1} \\ \xi_0 \sqrt{w_0^2 - 1} & -(\xi_0 w_0 + X_L(w_0)) \end{bmatrix} \begin{bmatrix} \omega_0(w_0) \\ \omega_1(w_0) \end{bmatrix} \quad (23)$$

Inverting equation and transforming from W to Z domain using the transformation given by equation (23) yield the transfer function for the angular velocities in delay from as equation (24) and (25). Angular velocity at the beginning of

the shaft and at the end of the shaft is calculated by equation (24) and (25) respectively.

Figure 7 is simulation of equations (24) and (25) in the MATLAB Simulink and figure 8 show angular velocities at the beginning and at end of the shaft by inputting 7000 NM via prime mover.

$$\frac{\omega_0}{T_0}(Z_0^{-1}) = \left[\frac{(1 + \xi_0 \beta_L) + (\xi_0 \beta_L - 1 - \alpha_L) z_0^{-1} + (\alpha_L) z_0^{-2}}{1 + \frac{(1 - \alpha_L - \xi_0 \beta_L)}{(1 + \xi_0 \beta_L)} z_0^{-1} + \frac{(-\alpha_L)}{(1 + \xi_0 \beta_L)} z_0^{-2}} \right] \quad (24)$$

$$\frac{\omega_1}{T_0}(Z_0^{-1}) = \left[\frac{(2 \xi_0 \beta_L) z_0^{-\frac{1}{2}}}{1 + \frac{(1 - \alpha_L - \xi_0 \beta_L)}{(1 + \xi_0 \beta_L)} z_0^{-1} + \frac{(-\alpha_L)}{(1 + \xi_0 \beta_L)} z_0^{-2}} \right] \quad (25)$$

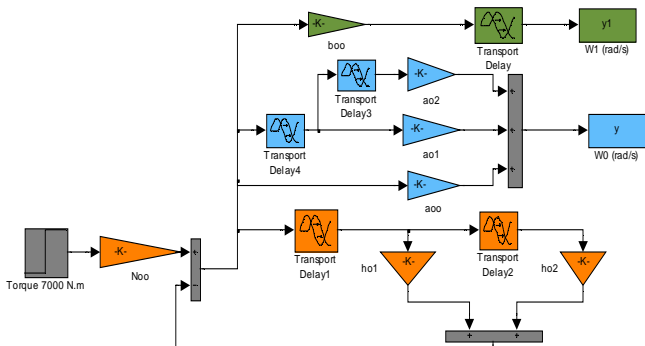

Fig. 7 Simulation of distributed lumped model technique in MATLAB Simulink

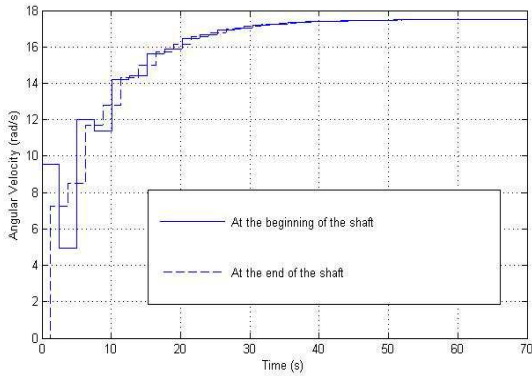

Fig. 8 Angular Velocities at the first and at the end of the shaft by distributed lumped model

TABLE II
MODEL PARAMETER FOR DRILL STRING SYSTEM

Quantity	Symbol	MKS Value	MKS Dimension
Mass Density	ρ	8009	ML^{-3}
Shear Modulus	G	$0.796 * 10^{11}$	$ML^{-1}T^{-2}$
Outer radius	r_o	0.0841	M
Inner radius	r_i	0.074942	M

Length	l	4000	M
Bearing friction	D_L	400	Nms / rad

By using of the data of table 2, Damping in this model is assumed $D_L = C_r + C_b = 400$ (Nms / rad) and this friction is spread all the drill string.

Also inertia is assumed, total inertia of drill string and drill collar and bits $J_L = J_r + J_b = 2500$ (kgm^2).

According to this equation $Z_j^{-1} = e^{-2\Gamma_j l_j} = e^{-\frac{T_p}{2}}$, $2\Gamma_j l_j = T_p$, Delay time is 2.536 sec. Delay time is directly related to the length of the drill string, therefore by increasing the length of the shaft, the resolution of the graph have been decreased. L_j and C_j are connected with properties of drill pipe and it is stable.

Figure 9 and figure 10 show the comparison of the angular velocity of the drill pipe by distributed lumped model and lumped model. Distributed lumped model has lower oscillations than lumped model.

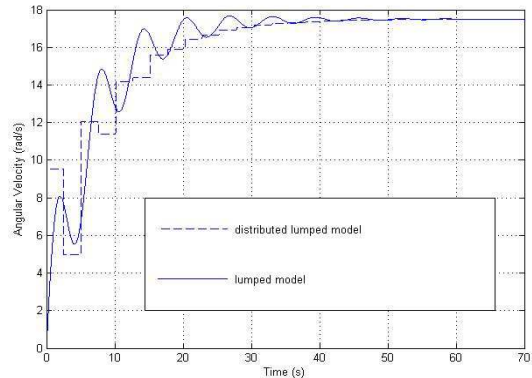

Fig. 9 The comparison of the Angular velocity of the drill string by distributed lumped model and lumped model at the beginning of the shaft

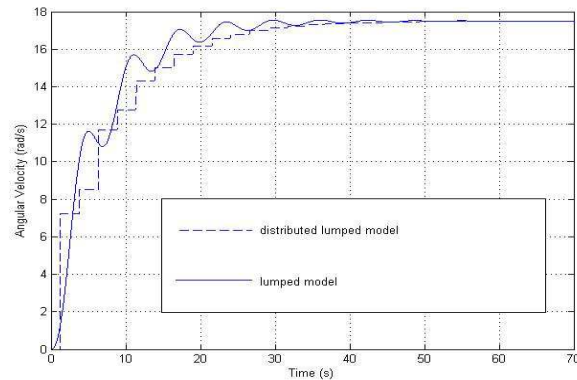

Fig. 10 The comparison of the Angular velocity of the drill string by distributed lumped model and lumped model at the end of the shaft

V.CONCLUSION

By exploring Figures 9&10 which represent the transient responses of the drill string using two different approaches.

These are distributed lumped modelling and lumped modelling respectively. It can be seen that the accuracy of distributed lumped modelling systems decrease when the drill string length increases.

Figure 10 illustrates angular velocities at the end of the long shaft (4000 meters) by lumped modelling technique. It starts to rotate as the same time of the first part does due to torque implementation. Therefore this modelling is not adaptable to real drill string. And also this figure in case of the distributed lumped modelling shows that drill string starts to rotate however with delay time which is related to the length of the drill string, this delay time is increased by increasing the length of the drill string.

The main problem of using lumped modelling approach is that it works out the results based on the user assumption which can have a significant effect on the output results. Moreover the assumption range varies according to the length of the string and hence this could even reduce the accuracy of the lumped modelling generated results.

REFERENCES

- [1] R.C. Rosenberg and D.C. Karnopp, Introduction to Physical System Dynamics, McGraw- Hill Book Company, New York, 1983.
- [2] A.A. Abdul-Ameer, H. Bartlett and A.S. Wood, "Modelling and simulation of a vehicle dynamometer using hybrid modelling technique, in multi-body Dynamics: Monitoring and Simulation technique," Professional Engineering Publishing Limited, London, PP. 327-335, 2000.
- [3] M. Navaroo-lopez, D. Cortes. "Sliding-mode control of a multi-DOF oilwell drilling with stick-slip oscillations". American control Conference, July, 2007.
- [4] S. S. I. Rizvi, H. Bartlett and R. Whalley."Distributed-Lumped modelling and simulation of ship and propulsion plant dynamic in application of Multi-Variable." University of Bradford, UK, 1998.
- [5] A.A. Abdul-Ameer, Mathematical Modelling and Simulation of Mechanical Systems, PhD Thesis, Bradford University, Bradford-UK. 2001.
- [6] R. Suarez and E. Lopez, "Practical approach to modelling and controlling stick-slip oscillation in oil well drill string," International Conference on control application, September 2004, Taipei Taiwan.
- [7] R. Whalley, H. Bartlett and M. Ebrahimi, "Analytical solution of distributed-lumped parameter network models," Proc ImechE., Vol.211, Part 1, pp.203-218, 1997.
- [8] S. Devereux, Drilling Technology in Nontechnical Language, Penn well corporation, Oklahoma, USA.,1999.
- [9] R. I. Leine and D. H. Van Campen, "Stick-slip whirl interaction in drill string dynamics," Department of mechanical engineering, Eindhoven university of technology, The Netherlands, 2003, Email: R.I.Leine@tue.nl.