

Properties of Biodiesel Produced by Enzymatic Transesterification of Lipids Extracted from Microalgae in Supercritical Carbon Dioxide Medium

Hanifa Taher, Sulaiman Al-Zuhair, Ali H. Al-Marzouqi, Yousef Haik, Mohammed Farid

Abstract—Biodiesel, as an alternative renewable fuel, has been receiving increasing attention due to the limited supply of fossil fuels and the increasing need for energy. Microalgae are promising source for lipids, which can be converted to biodiesel. The biodiesel production from microalgae lipids using lipase catalyzed reaction in supercritical CO₂ medium has several advantages over conventional production processes. However, identifying the optimum microalgae lipid extraction and transesterification conditions is still a challenge. In this study, the quality of biodiesel produced from lipids extracted from *Scenedesmus* sp. and their enzymatic transesterification using supercritical carbon dioxide have been investigated. At the optimum conditions, the highest biodiesel production yield was found to be 82%. The fuel properties of the produced biodiesel, without any separation step, at optimum reaction condition, were determined and compared to ASTM standards. The properties were found to comply with the limits, and showed a low glycerol content, without any separation step.

Keywords—Biodiesel, fuel standards, lipase, microalgae, Supercritical CO₂

I. INTRODUCTION

ALKALINE catalysts, such as sodium hydroxide, have been widely used in biodiesel production from several sources. However, the quality of the feedstock has a significant effect on the reaction yield, where Free Fatty Acids (FFA) and moisture contents showed to be the key parameters to define the feedstock feasibility. Alkaline catalysts have been found not practical with a feedstock of high FFA, due to soap formation, which reduces the final product quality and adds difficulties in the byproduct, glycerol, separation from biodiesel. The use of immobilized lipases can overcome this problem, and presents a more environmental friendly alternative operating at lower temperatures [1].

Supercritical fluids (SCF) such as supercritical CO₂ (SC-CO₂), has received increasing attention in bio-catalysis applications as a green reaction medium [2]. SC-CO₂ has many useful features such as being non-flammable, inexpensive, available in sufficient quantities, and has moderate critical temperature (31.3°C) and pressure (72.8 bar). Compared to conventional organic solvents, SC-CO₂ usually yields a faster reaction rate [3], and offers easy product

separation, while maintaining the same advantages for lipase catalysis as organic solvents do, such as solubilization of lipids and favoring esterification over hydrolysis. Another advantage of using SC-CO₂ is that the produced biodiesel, dissolved in SC-CO₂, does not require a glycerol separation unit, as in conventional techniques, since the solubility of glycerol is low in SC-CO₂, and stay in the reactor resulting in the direct production of high purity biodiesel [4].

Due to SC-CO₂ advantages over conventional organic solvents, the application of the high cost SC-CO₂ process may be justified in oil extraction. However, its justification for biodiesel production may not be evident, despite its positive effect on reducing inhibition effects and easy product separation. Nevertheless, a combined continuous process of extracting oil using SC-CO₂ and the use of the extracted oil for biodiesel production using immobilized lipase in SC-CO₂ in one integrated system would be feasible. In this continuous process, the oil that is extracted from microalgae is already dissolved in SC-CO₂, and can be fed directly to the enzymatic bioreactor to produce biodiesel without the need for further expensive pumping. In this way, the attractive advantages of performing the reaction in SC-CO₂ media will be gained, avoiding at the same time the disadvantage of high pumping cost. This continuous process has been tested in our previous work [5] and showed positive results. For commercial fuel use, the produced biodiesel must be analyzed. Several standards have been revised for fuels properties. Among these, ASTM and EN [6], shown in Table I, are the most commonly used.

II. MATERIALS AND METHODS

A. Biodiesel Production Experiment

The integrated extraction-reaction system for biodiesel production directly from dried biomass of *Scenedesmus* sp. microalgae is described in our previous paper [5]. Briefly, SC-CO₂ was allowed to pass through an extraction cell containing the dried biomass. The output stream, containing the extracted lipids was mixed with a specified ratio of pressurized methanol-*tert*-butanol solution and the mixture then entered the packed bed bioreactor containing immobilized enzyme. The produced Fatty Acids Methyl Esters (FAMES) were then separated from the CO₂ by depressurization and the amount was determination by Gas chromatography equipped with flame ionization detector (GC-FID). Fig. 1 shows a schematic diagram of the experimental set-up.

Sulaiman Al-Zuhair is with the UAE University, 15551 Al Ain, UAE (corresponding author; e-mail: s.alzuhair@uaeu.ac.ae).

Hanifa Taher is with Masdar Institute of Technology, Abu Dhabi, UAE.

Ali H. Al-Marzouqi is with the UAE University, Al Ain, UAE.

Yousef Haik is with Qatar University, Doha, Qatar.

Mohamed Farid is with Auckland University, Auckland, New Zealand.

TABLE I
FUEL STANDARDS AND TEST METHODS FOR PURE BIODIESEL

Property	Method		Limit	
	ASTM	EN	ASTM	EN
Acid value (mgKOH g ⁻¹)	ASTM D664	EN 14104	0.5 max	0.5 max
Water and sediment	ASTM D2709	EN ISO 12937	0.05 ^a max	500 ^b max
Ester content	-	EN 14103	-	96.5 ^d min
Free glycerol	ASTM	EN 14105	0.02 ^c	0.02 ^d
Total glycerol	ASTM	EN 14106	0.24 ^c	0.25 ^d
Sulfur content	ASTM D874	ISO 3897	0.02 ^c	0.02 ^d
Phosphorous content	ASTM D4951	EN 14107	0.001 ^e max	10 ^e max
Cetane number	ASTM D613	EN ISO 5165	47.0 min	51.0 min
Cloud point	ASTM D2500	-	-	-
Oxidation stability (h)	-	EN 14112	3 min	6 min
Flash point (°C)	ASTM D93	EN ISO 3679	93 min	120
Density, (kg m ⁻³ , 15 °C)	-	EN ISO 3675	-	860-900
Kinematic viscosity, (mm ² s ⁻¹ , 40 °C)	ASM D445	EN ISO 3104	1.9-6.0	3.5-5.0

^a vol %, ^b mg kg⁻¹, ^c wt %, ^d mol %, ^e mg kg⁻¹

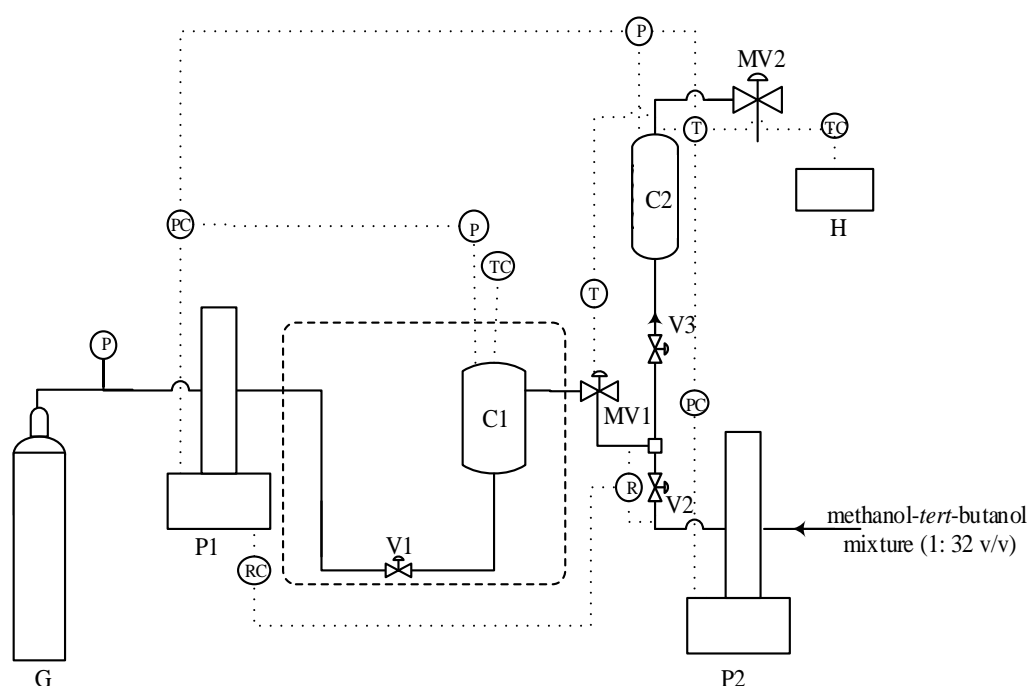

Fig. 1 Schematic diagram of the integrated fat extraction-biodiesel production system. G: CO₂ cylinder, P1: high pressure pump 1, P2: high pressure pump 2, V1: pre-extraction valve, V2: enriched stream valve, V3: methanol flow valve, V4: reaction mixture valve, V5: product elution valve, H: temperature controller, C1: extraction cell and C2: reaction cell

B. Determination of Biodiesel Properties

The properties of produced biodiesel were tested and compared to those of the commercial diesel fuel available at the petrol station (Abu Dhabi National Oil Company, UAE), and with those of ASTM and EN diesel standards. The determined properties were; density, kinematic viscosity, flash point, pour point, caloric value, acid value, and sulfur and free glycerol contents. The density and kinematic viscosity were tested at 40°C using SVM300 Stabinger Viscometer (Anton Paar, Austria). The flash point, pour point and caloric values were determined using flash point analyzer (Stanhope Seta, England), Seta Cloud and Pour Point Cryostat (Stanhope Seta

ltd, England) and bomb calorimeter (Parr Instrument Company, USA), respectively. The sulfur content was determined using Tanaka sulfur meter (RX-360 SH, Japan). The acid value was calculated by titration with KOH, and total free glycerol content was determined by spectrophotometric method [7]. Briefly in this analysis, a calibration curve between UV absorbance and glycerol standard solution was first prepared by preparing a series of 0-2 ml standards and diluted them with solvent solution of 1:1 ratio deionized water and ethanol in a way to get a final volume of 2 ml in each tube. The final concentrations of glycerol were 0-18.75 mg kg⁻¹. 1.2 ml of sodium periodate (10 mM) was then added to each

tube, shook and followed by the addition of 1.2 ml of acetylacetone (0.2 M). The solution was then heated at 70 °C in SI-300 shaker incubator for 1 min, and cooled down immediately by immersing in tap water at room temperature. The absorbance of the standards samples were read at a wavelength of 410 nm and the calibration curve was then generated. The same procedure was carried out with the fuel sample, and the absorbance was read against a blank sample contains no glycerol reference solution. The cetane number (CN) was calculated according to [8], using (1).

$$CN = 46.3 + \frac{5458}{SV} - 0.225 IV \quad (1)$$

where, CN is the cetane number, and SV and IV are the saponification and iodine values calculated, according to [9] from the chemical composition of produced FAMES using (2) and (3), respectively.

$$IV = \sum \frac{254 D A_i}{MW_i} \quad (2)$$

$$SV = \sum \frac{560 A_i}{MW_i} \quad (3)$$

where, D, A_i and MW_i are number of double bond, percent composition and the molecular weight of particular ester, respectively.

III. RESULTS AND DISCUSSIONS

The operational stability and reusability of the immobilized lipase which are important factors affecting the production cost. It was shown that the same enzyme bed was successfully reused with six cycles of fresh biomass and the highest produced FAME was 329.2 mg collected after 480 min of operation, as tested in [5]. It was also shown that the production was almost linear, but started to deviate in sixth cycle, mainly due to increased accumulated by-product, glycerol, which was not carried out due to its low solubility in SC-CO₂ [4]. To further confirm this explanation, the glycerol content in the product has been measured and was found to be only 33 mg kg⁻¹. This low amount of glycerol in the product proves that the glycerol must have been left in the bed. The enzyme bed was further utilized with fresh biomass in new sets of cycles, after washing the enzyme with tert-butanol. The bed was successfully reused after washing.

The fuel properties of enzymatically produced biodiesel from microalgae lipids extracted by SC-CO₂ are shown in Table II. For comparison, the values of commercial diesel available in local petrol station have been also measured and shown in the table. The table also shows the standard limits.

The results show that the properties of produced FAMES are close to those of the commercial diesel and of the diesel standard. The low viscosity of the produced biodiesel indicates that it can be directly used in existing engines. The slightly lower heating value was expected due to the oxygen content of the biodiesel, which is not present in conventional diesels. However, the presence of the oxygen may help to achieve complete combustion, which is advantageous. The flash point

of the produced biodiesel was almost 45-54 % higher than that of diesel, which is safer for storage and transportation. Most importantly, the present results show that the produced biodiesel has low sulfur content below the fuel limit, according to ASTM D874 method, which is expected as biomass has very low sulfur content. This results in low SO_x emissions. The glycerol content is an important feature that determine the success of the process altogether. It was claimed that using immobilized lipase in SC-CO₂ would result in avoiding the need of glycerol separation step. The free glycerol content in the produced biodiesel was found to be very low, which proves this claim.

TABLE II
PROPERTIES OF PRODUCED MICROALGAE BIODIESEL AND MARKET DIESEL

Property	Algal biodiesel	Diesel	ASTM	EN
Viscosity (mP-s @ 40°C)	5.3	2.6	1.9-6	33.5-5
Flash point (°C)	105	68-72	93 ^a	120 ^a
Specific gravity	0.876	0.858	-	0.86-0.9
Higher heating value (MJ kg ⁻¹)	39.842	42.2	-	-
Cetane number*	57.6	50.3	47 ^a	51 ^a
Acid value (mg KOH g ⁻¹)	0.32	-	0.5 ^b	0.5 ^b
Cloud point (°C)	7	-13	-	-
Pour point (°C)	-1	-22	-	-
Sulfur content (wt %)	0.008	-	0.02	0.02
Free glycerol (mg kg ⁻¹)	33	-	0.02	0.02

* Calculated using (1), ^a minimum limit, ^b maximum limit

IV. CONCLUSION

Supercritical CO₂ has been successfully used for biodiesel production from extracted microalgae lipids. There was no need for any solvent separation unit, and the biodiesel produced by depressurization was easily collected. Another advantage of using SC-CO₂ is that the produced biodiesel dissolved in SC-CO₂ does not require a glycerol separation unit, as in conventional techniques, since the solubility of glycerol is low in SC-CO₂, and stay in the reactor resulting in the direct production of high purity biodiesel. The properties of the produced biodiesel, without any purification step were found to be close to those of conventional diesel, and comply with the international standards.

REFERENCES

- [1] S. Al-Zuhair, "Production of biodiesel: possibilities and challenges". *Biofuels, Bioproducts and Biorefining*, Vol. 1, pp. 57-66, 2007.
- [2] Z.k. Wimmer and M. Zarevcka, "A review on the effects of supercritical carbon dioxide on enzyme activity". *International Journal of Molecular Sciences*, Vol. 11, pp. 233-253, 2010.
- [3] M. Kondo, K. Rezaei, F. Temelli, and M. Goto, "On-line extraction-reaction of canola oil with ethanol by immobilized lipase in SC-CO₂". *Industrial & Engineering Chemistry Research*, Vol. 41, pp. 5770-5774, 2002.
- [4] Y. Medina-Gonzalez, T. Tassaing, S. Camy and J.S. Condoret, "Phase equilibrium of the CO₂/glycerol system: Experimental data by in situ FT-IR spectroscopy and thermodynamic modeling", *The Journal of Supercritical Fluids*, Vol. 73, pp. 97-107, 2014.
- [5] H. Taher, S. Al-Zuhair, A. AlMarzoqui, Y. Haik, and M. Farid, "Enzymatic biodiesel production of microalgae lipids under supercritical carbon dioxide: process optimization and integration". *Biochemical Engineering Journal*, Vol 15, pp. 103-113, 2014.

- [6] European Committee for Standardization. "Committee for Standardization Automotive fuels - fatty acid FAME (FAME) for diesel engines - requirements and test methods", 2003.
- [7] P. Bondioli, and L. Della Bella, "An alternative spectrophotometric method for the determination of free glycerol in biodiesel". *European Journal of Lipid Science and Technology*, Vol. 107, pp. 153-157, 2005.
- [8] K. Krisnangkura, "A simple method for estimation of cetane index of vegetable oil methyl esters". *Journal of the American Oil Chemists Society*, Vol. 63, pp. 552-553, 1986.
- [9] P. Kalayasiri, N. Jeyashoke, and K. Krisnangkura, "Survey of seed oils for use as diesel fuels". *Journal of American Oil Chemist's Society*, Vol. 73, pp. 471-474, 1996.