

Prediction of Temperature Distribution during Drilling Process Using Artificial Neural Network

Ali Reza Tahavvor, Saeed Hosseini, Nazli Jowkar, Afshin Karimzadeh Fard

Abstract—Experimental & numeral study of temperature distribution during milling process, is important in milling quality and tools life aspects. In the present study the milling cross-section temperature is determined by using Artificial Neural Networks (ANN) according to the temperature of certain points of the work piece and the point specifications and the milling rotational speed of the blade. In the present work, a first three-dimensional model of the work piece is provided and then by using the Computational Heat Transfer (CHT) simulations, temperature in different nodes of the work piece are specified in steady-state conditions. Results obtained from CHT are used for training and testing the ANN approach. Using reverse engineering and setting the desired x , y , z and the milling rotational speed of the blade as input data to the network, the milling surface temperature determined by neural network is presented as output data. The desired points temperature for different milling blade rotational speed are obtained experimentally and by extrapolation method for the milling surface temperature is obtained and a comparison is performed among the soft programming ANN, CHT results and experimental data and it is observed that ANN soft programming code can be used more efficiently to determine the temperature in a milling process.

Keywords—Milling process, rotational speed, Artificial Neural Networks, temperature.

I. INTRODUCTION

MILLING is one of the machining processes, widely used in manufacturing and industry. In almost 50 percent of industrial machining processes, milling is used. Compared with other cutting processes, heat generation and tool temperature during the milling process is higher under similar conditions. The milling cross-section temperature has a great influence on the milling tool lifetime and the surface quality. In this process, many parameters such as cutting speed, cutting angle, lubricant liquid and etc. play a vital role. For further detailed analysis, new approaches to reduce cost of studies and saving computational time, soft programming methods such as Artificial Neural Network can be an alternative and new attempt. Artificial Neural Networks have been used by various researchers for modeling and predictions in the field of energy engineering systems. These applications are widely reviewed

Ali Reza Tahavvor is with the Department of Mechanical Engineering, College of Engineering, Shiraz Branch, Islamic Azad University, Shiraz, Iran (corresponding author to provide phone: +98-917-315-4695; fax: +98-71-36191-679; e-mail: Tahavvor@gmail.com).

Saeed Hosseini and Afshin Karimzadeh Fard are with the Department of Mechanical Engineering, College of Engineering, Shiraz Branch, Islamic Azad University, Shiraz, Iran (e-mail: Ho.s@icloud.com, Af_kfard@yahoo.com).

Nazli Jowkar is with the Department of Agriculture, College of Agriculture, Shiraz Branch, Islamic Azad University, Shiraz, Iran (e-mail: jowkarnazli@yahoo.com).

by [1]. ANN and other soft computing methods have also been used by various researchers in other fields of engineering [2]-[4]. The various numerical, analytical, and experimental methods like output functions, CFD simulations, and measuring the temperature of lubrication liquid are used to estimate and obtain the temperature of drilling section [5]. Reference [6] used ANN to predict temperature field of drilled hole's cross section. According to its results ANN is one of the fastest and most accurate approaches among other methods to predict temperature field. Computational Fluid Dynamics method is used to generate data base of ANN for cross section temperature of milling process. ANN outputs were verified by experimental measurements [7].

The effect of heat treatment on surface roughness is investigated [8]. Various numerical, analytical and experimental methods are used such as extrapolating functions, CHT simulations and recently, ANN method is being used to predict the results of experimental and computational heat transfer. Finite element method is used for modeling of temperature rise during drilling [9]. Also, a new method was presented to predict the maximum temperature of dry drilling based on finite element approach [10]. Selecting tool material based on needs and price using fuzzy logic theory has been studied [11].

The purpose of this study is to find out whether ANN approach is an appropriate method to determine the milling cross-section temperature or not. In this work the effect of the milling blade rotational speed and ambient temperature on the milling surface temperature has been investigated. Finally, comparison is made between experimental measurements and numerical results.

II. PROBLEM DEFINITION

Physical model for work piece and the related grid arrangement for CHT solution are shown in Fig. 1. The flow is symmetric about a vertical and horizontal plane passing through the milling cross-section. Therefore the half-plane is considered as a model.

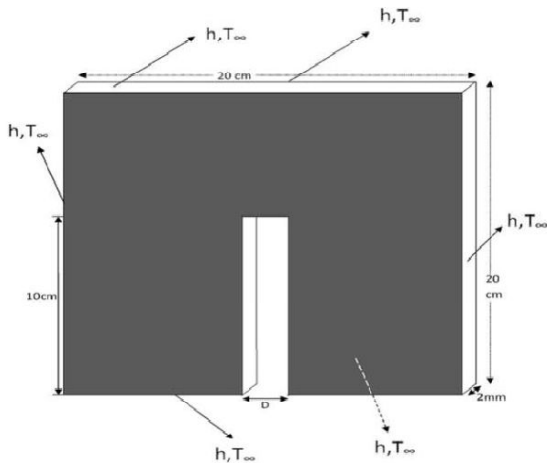

Fig. 1 Physical geometry and grid distribution

III. COMPUTATIONAL PROCEDURE

For simulation, three-dimensional and steady-state conditions with constant thermo-physical properties are considered. Ambient temperature is 25°C and the milling sections temperature change according to their locations. Results are obtained using air at atmospheric pressure with a quadrangular model of dimensions 20*20cm and mill bit rotational speed of 100 to 160rpm and total coefficient of heat transfer around and above and below the surface or the piece of work as shown in Table I. A convergence criterion is taken as 10E-6. Steel is used as material type. Some structured grid dimensions are tested to obtain optimum grid dimension. After several tests, it is decided that the number of grids are sufficiently fine for estimation of a grid independent solution and grids temperature are used as ANN input data. For the process of milling HSS milling blade rotational speed are used. Also, temperature of four desired grids, as shown in Fig. 2, are measured by using four channels thermometer with thermocouples type K. grid 1 is located at point (0,14) from the milling cross-section, grid 2 at point (0,12), grid 3 at (1.5,7) and grid 4 at (1.5,4.5). Therefore by using the Richardson extrapolation method the temperature of each point of the cross-section is calculated.

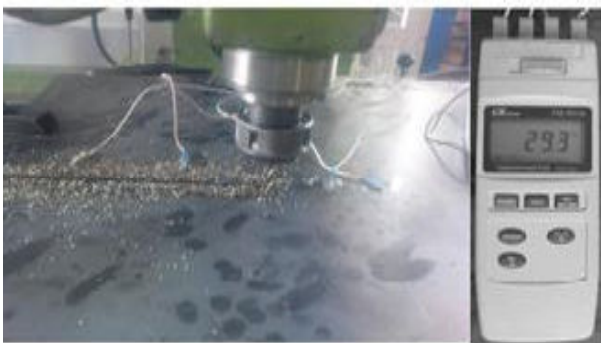

Fig. 2 Thermometer and work piece

TABLE I
TOTAL COEFFICIENT OF HEAT TRANSFER

Rotational speed (rpm)	interest location	coefficient of heat transfer (w/m2.k)	surface temperature (k)
100	side surface	21.02	318
100	above surface	7.05	318
100	below surface	4.09	318
130	side surface	22.43	323
130	above surface	8.24	323
130	below surface	4.12	323
160	side surface	25.43	353
160	above surface	9.24	353
160	Below surface	4.52	353

IV. ARTIFICIAL NEURAL NETWORKS

Neural networks are composed of simple elements operating in parallel. These elements are inspired by biological nervous systems. As in nature, the network functions are determined largely by the connections between elements. We can train a neural network to perform a particular function by adjusting the values of the connections (weights) between elements. Fig. 3 shows a highly simplified model of an artificial neuron, which may be used to simulate some important aspects of the real biological neuron.

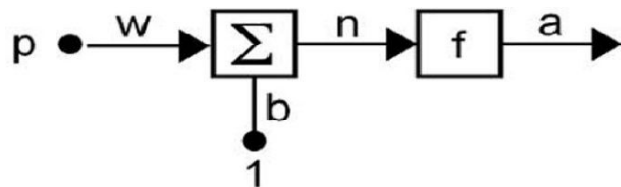

Fig. 3 An artificial neuron

In such a system, excitation is applied to the input of the network. Following some suitable operation, it results in a desired output. At the synapses, there is an accumulation of some Potential which, in the case of the artificial neurons, is modeled as a connections weight. These weights are continuously modified based on suitable learning rules.

A. Artificial Neural Network Architecture

In this work a multilayer network with different training algorithm is used and it is found that the Back-propagation algorithm with Levenberg-Marquardt learning rule is the best choice for this analysis because of the accurate and faster training procedure. Input vector consists of four elements: dimensions x, y, z and milling blade rotational speed. Output vector and target vector consist of one element: milling cross-section temperature. Input-output pairs are presented to the network, and weights and biases are adjusted to minimize the error between the network output and the target value. Inputs and targets are normalized between 0 and 1, so logistic sigmoid function is used for transfer function. Fig. 4 shows the network used in this work, which has three layers of neurons: two hidden layers and an output layer.

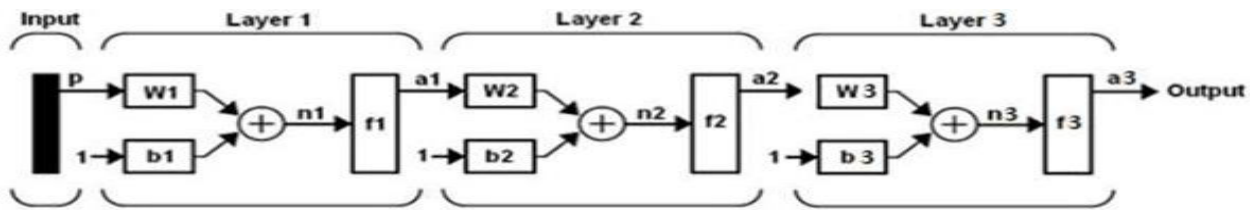

Fig. 4 Three-layer feed-forward neural network

B. Levenberg-Marquardt Algorithm

The Levenberg-Marquardt [12]-[14] algorithm is an iterative technique that locates the minimum of a multivariate function. It has become a standard technique for non-layer least-squares problems, widely adopted in a broad spectrum of disciplines. LM can be thought of as a combination of steepest descent and the Gauss-Newton method. When the current solution is far from the correct one, the algorithm behaves like a steepest descent method: slow, but guaranteed to converge. When the current solution is close to the correct solution, it becomes a Gauss-Newton method. For LM algorithm, the performance index to be optimized is defined as [15]:

$$F(w) = \sum_{p=1}^P [\sum_{k=1}^K (d_{kp} - o_{kp})^2] \quad (1)$$

where w consists of all weights of the network, d and o are the desired and actual value of the output and the pattern respectively, P is the number of patterns, and K is the number of the network outputs. Weights are calculated using the following equation:

$$w_{i+1} = w_i - (H + \mu_i I)^{-1} \nabla F(w_i) \quad (2)$$

where H is the hessian matrix evaluated at W_i . This update rule is used as follows. If the error goes down following an update, it implies that our quadratic assumption on $F(w)$ is working and we reduce μ (usually by a factor of 10) to reduce the influence of gradient descent. On the other hand, if the error goes up, we would like to follow the gradient more and so μ is increased by the same factor. So, the levenberg algorithm is:

1. Do an update as directed by the rule above.
2. Evaluate the error at the new parameter vector.
3. If the error has increased as a result the update, then retract the step (i.e. reset the weights to their previous values) and increase μ by a factor of 10 or some such significant factor, then go to (1) and try an update again.
4. If the error has decreased as a result the update, then accept the step (i.e. keep the weights at their new values) and decrease μ by a factor of 10 or so.

The above algorithm has the disadvantage that if the value of μ is large, the calculated hessian matrix is not used at all. We can derive some advantage out of the second derivative even in such cases by scaling each component of the gradient according to the curvature. This should result in larger movement along the directions where the gradient is smaller so that the classic "error valley" problem does not occur any more. This crucial insight was provided by [12]. He replaced

the identity matrix in (2) with the diagonal of the hessian resulting in the Levenberg-Marquardt update rule.

$$w_{i+1} = w_i - (H + \mu_i \text{diag}(h))^{-1} \nabla F(w_i) \quad (3)$$

Since the hessian is proportional to the curvature of $F(W)$, (6) implies a large step in the direction with low curvature (i.e., almost flat terrain) and a small step in the direction with high curvature (i.e., a steep incline).

It is to be noted that while the LM method is in no way optimal but is just a heuristic, it works extremely well in practice. The only flaw is its need for matrix inversion as part of the update. Even though the inverse is usually implemented using clever pseudo-inverse methods such as singular value decomposition, the cost of the update becomes prohibitive after the model size increases to a few thousand parameters. For moderately sized models (of a few hundred parameters) however, this method is much faster.

V. RESULTS AND DISCUSSIONS

Artificial neural network is used to determine new results from the generated data to save effort and computation time for determining temperature of milling cross-section for range of milling blade rotational speed and cross-section temperatures. Results for certain cases are compared with CHT solution. In this study, milling blade rotational speed, changed between 100 to 160 rpm and milling cross-section temperature, changed according to dimensions x , y , z and 62000 data are chosen for each rotational speed and temperature generated from CHT code. Data of $\omega = 100, 130$ and 160 rpm are used for training ANN. ANN is trained for temperature values. Some results of training procedure are illustrated in Figs. 5-7 and Tables II & III.

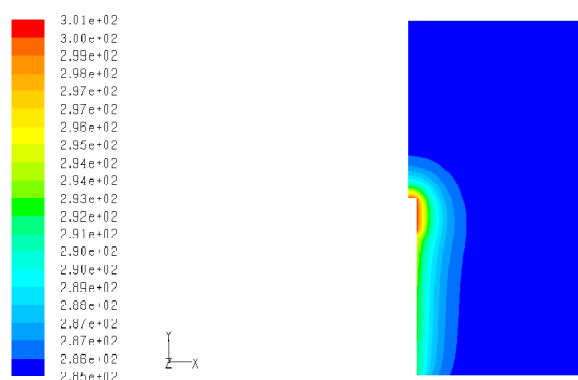
Fig. 5 Contours of static temperature (k) from CHT for $\omega=100$ rpm

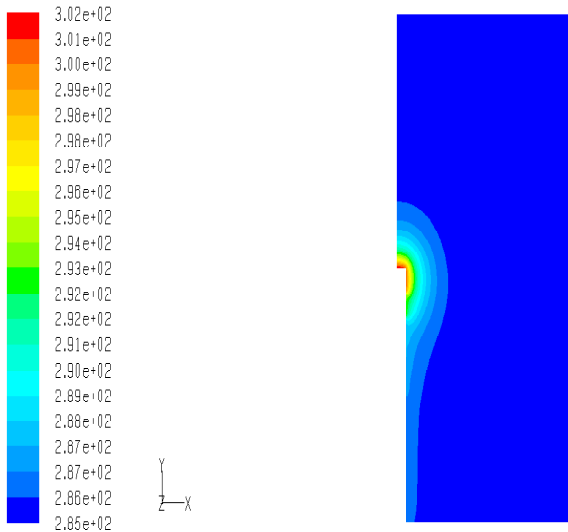

Fig. 6 Contours of static temperature (k) from CHT for $\omega=130$ rpm

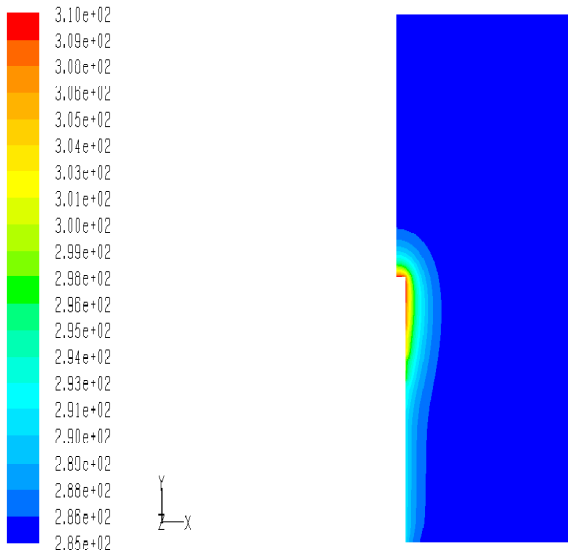

Fig. 7 Contours of static temperature (k) from CHT for $\omega=160$ rpm

used for testing and providing new physics of temperature. Very good compliance can be observed between results of ANN and CHT simulation. It is evident that ANN method is capable of accurately determining temperature from the generated data.

TABLE III
TEMPERATURE DATA FROM CHT AND ANN

rotational speed (rpm)	X	Y	Section	Section(ANN)
100	0.5	0.5	349.7	350.4
100	0.5	1.5	351.5	351.6
100	0.5	2.5	351.7	352.2
100	0.5	3.5	353.5	353.02
100	0.5	4.5	355	354.8
100	0.5	5.5	355.8	355.2
100	0.5	6.5	356	355.86
100	0.5	7.5	358.5	360.18
100	0.5	8.5	362.7	363.18
100	0.5	9.5	369.5	370.1
130	0.8	0.5	343.8	342.95
130	0.8	1.5	344.7	343.4
130	0.8	2.5	344	343.16
130	0.8	3.5	346	346.18
130	0.8	4.5	346.8	334.08
130	0.8	5.5	343	342.01
130	0.8	6.5	351.8	350.16
130	0.8	7.5	361	359
130	0.8	8.5	365.3	364.11
130	0.8	9.5	371	370.7
160	1	0.5	352	352.8
160	1	1.5	355	354.9
160	1	2.5	357	357.3
160	1	3.5	360	359.17
160	1	4.5	362	362.16
160	1	5.5	369	368.6
160	1	6.5	372.3	372.1
160	1	7.5	373.3	372.96
160	1	8.5	376	376.14
160	1	9.5	378.5	378.17

To indicate the closeness of results diagrams (1) and (2) which compare the results of ANN and CHT simulation are used. Also, statistical indicators R-squared were used to evaluate fitting of the network as follows:

$$R^2 = 1 - \frac{\sum(T_{Exp} - T_{ANN})^2}{\sum(T_{Exp} - T_{mExp})^2} \quad (4)$$

where TExp (temperature) is the value obtained from experiment, TANN is the determined value of T by ANN method and TmExp is the mean experimental value of T values. This statistic measures how successful the fit is in explaining the variation of the data. A value closer to 1 indicates a better fit.

Results of R2 are presented in Table VI. As can be seen in this table, the values R2 are very close to 1. This means that there is an excellent correspondence between ANN and CHT.

TABLE II
EXPERIMENTAL DATA AND ANN SIMULATION RESULTS

rotational speed (rpm)	X	Y	Z	Temperature (k)	
				experiment	ANN
100	8.1	2.15	0.2	304.90	304.00
100	9.52	2.15	0.2	306.99	306.55
100	9.76	2.15	0.2	309.7	309.04
130	8.15	0.35	0.2	312.00	312.6
130	6.04	0.35	0.2	316.06	315.78
130	0.28	14.6	0.2	320.03	319.5
160	0.35	14.6	0.2	322.42	322.01
160	0.35	15.1	0.2	338.01	337.99
160	0.35	14.8	0.2	339.09	339.02

Comparing ANN with CHT simulation reveals that differences of cross-section temperature are negligible.

The new results from ANN scheme for some of data are

TABLE VI
R-SQUARE VALUES FOR VARIOUS TESTS

Ω (RPM)	100	130	160
R^2	0.9966	0.9970	0.9911

VI. CONCLUSIONS

- ANN soft programming code for determining milling cross-section temperature in machining processes for various rotational speed of milling blades and dimensions of different point compared with the CHT code.
- Very good compliance was found between ANN scheme and CHT simulation.
- ANN method can easily be used to determine new results for temperature prediction in milling process simulation with considerably less computational cost and time.
- Back-propagation algorithm with Levenberg-Marquardt learning rule is the best choice for training this type of ANNs because of the accurate and faster training procedure.

REFERENCES

- [1] S. A. Kalogirou, Applications of artificial neural-networks for energy systems, *Applied Energy*, 67 (2000) 17-35.
- [2] Salehi, J., Zadeh, P. M. & Mirshams, M. Collaborative optimization of remote sensing small satellite mission using genetic algorithms. *Iranian Journal of Science and Technology. Transactions of Mechanical Engineering*, Vol. 36, pp. 117-128, 2010.
- [3] Mousavi, S. A., Hashempour, M., Sadeghi, M., Petrofsky, J. S. & Prowse, M. A. A fuzzy logic control system for the Rotary dental instruments. *Iranian Journal of Science & Technology, Transaction B: Engineering*, Vol. 34, pp. 539-551, 2010.
- [4] Su-Bin Joo, Seung Eel Oh, Taeyong Sim, Hyunggun Kim, Chang Hyun Choi, Hyeran Koo, Joung Hwan Mun, Prediction of gait speed from plantar pressure using artificial neural networks, *Expert Systems with Applications*, Volume 41, Issue 16, Pages 7398-7405, 15 November 2014.
- [5] A. R. Tahavvor and S. Sepehrinia, prediction of the temperature of the hole during the drilling process, *IJST, Transactions of Mechanical Engineering*, Vol. 38, No. M1+, pp 269-274, 2014.
- [6] Ali Reza Tahavvor, Yasser Rezaei and Ahmad Afsari, Prediction of Cross-Section Temperature During Milling Process Using Artificial Neural Networks, *World Applied Sciences Journal* 19 (11): 1674-1680, 2012.
- [7] Babur Ozelcik, Eyup Bagci, Experimental and numerical studies on the determination of twist drill temperature in dry drilling: A new approach, *Materials & Design*, Volume 27, Issue 10, Pages 920-927, 2006.
- [8] F. Kahramani and A. Sagbas, An Investigation of the Effect of Heat Treatment on Surface Roughness in Machining by using Statistical Analysis, *Iranian Journal of Science & Technology, Transaction B: Engineering*, Vol. 34, No. B5, pp 591-595, 2010.
- [9] Kuang-Hua Fuh, Wen-Chou Chen, Ping-Wen Liang, Temperature rise in twist drills with a finite element approach, *International Communications in Heat and Mass Transfer*, Volume 21, Issue 3, Pages 345-358, May-June 1994.
- [10] Jian Wu, Rong Di Han, A new approach to predicting the maximum temperature in dry drilling based on a finite element model, *Journal of Manufacturing Processes*, Volume 11, Issue 1, Pages 19-30, January 2009.
- [11] N. Towhidi, R. Tavakkoli-moghadam and S. E. Vahdat, the use of fuzzy logic theory for selecting appropriate tool, *Iranian Journal of Science & Technology, Transaction B, Engineering*, Vol. 29, No. B6, 2005
- [12] Marquardt, D. W. An algorithm for least-squares estimation of nonlinear parameters. *SIAM, J. Appl. Math.*, Vol. 11, pp. 431-441, 1963
- [13] Wilamowski, B., Iplikci, S., Kaynak, O. & Efe, M. O., An algorithm for fast convergence in training neural networks. *proc. Int. Conf. Neural Network*, Washington, DC, USA, 2001
- [14] G. Manetti, Attainment of temperature equilibrium in holes during drilling, *Geothermics Volume 2, Issues 3-4, September-December 1973*, Pages 94-100.
- [15] Wilamowski, B. M., & Kaynak, O. (2000). Oil well diagnosis by sensing terminal characteristics of the induction motor. *Industrial Electronics, IEEE Transactions on*, 47(5), 1100-1107.