

# Prediction of Overall Efficiency in Multistage Gear Trains

James Kuria, John Kihiu

**Abstract**—A mathematical model for determining the overall efficiency of a multistage tractor gearbox including all gear, lubricant, surface finish related parameters and operating conditions is presented. Sliding friction, rolling friction and windage losses were considered as the main sources of power loss in the gearing system. A computer code in FORTRAN was developed to simulate the model. Sliding friction contributes about 98% of the total power loss for gear trains operating at relatively low speeds (less than 2000 rpm input speed). Rolling frictional losses decrease with increased load while windage losses are only significant for gears running at very high speeds (greater than 3000 rpm). The results also showed that the overall efficiency varies over the path of contact of the gear meshes ranging between 94% to 99.5%.

**Keywords**—Efficiency, multistage gear train, rolling friction, sliding friction, windage losses.

## NOMENCLATURE

$D$	Pitch diameter
$E$	Young's Modulus of elasticity
$F$	Gear face width
$F_R(\theta)$	Instantaneous rolling friction force
$G$	Material parameter
$h$	Lubricant film thickness, m
$k$	Ellipticity parameter
$P_R$	Rolling friction power loss
$P_S$	Sliding friction power loss
$P_W$	Windage power loss
$P_O$	Overall power loss
$P_i$	Input power
$P_h$	Hertzian pressure
$S$	Surface roughness
$t$	Time.
$U$	Speed parameter
$V_R$	Rolling velocity
$V_S$	Sliding velocity
$W_i$	Gear contact normal load
$\eta$	Lubricant dynamic viscosity
$\eta_o$	Overall efficiency
$\mu_i$	Instantaneous friction coefficient
$\nu$	Kinematic viscosity
$\theta$	Roll angle
$\nu$	Poisson's ratio
EHL	Electro-hydrodynamic Lubrication

## I. INTRODUCTION

J. Kuria is with the Department of Mechanical Engineering, Jomo Kenyatta University of Agriculture & Technology, Nairobi, Kenya e-mail: jkuria@eng.jkuat.ac.ke

J. Kihiu is Associate Professor, Department of Mechanical Engineering, Jomo Kenyatta University of Agriculture and Technology, Nairobi, Kenya email: kihiusan@yahoo.com

**G**EARS are the most common power transmission systems in industrial machinery, automobiles, aircrafts, marine vessels et cetera. The efficiency of these power transmission systems is an important design factor due to the following reasons [1]:

- i. Efficient power transmission systems ensure fuel economy of automobiles, marine vessels and aircrafts.
- ii. With less fuel consumption, less pollutant gases and particulate are emitted to the environment
- iii. Since power losses amount to heat generation within the gearbox, several gear failure modes such as scoring and fatigue can be directly influenced by the efficiency of the gearing system.
- iv. Improved efficiency of a gearing system can reduce the requirements on the capacity of the lubrication system and the gearbox lubricant and thereby reducing the operation costs of the system.
- v. Efficiency prediction can assist in estimating the power requirements during the design stage of a machine and thus ensuring that the system operates reliably. It can also assist in estimating the power output for a given power input.

Extensive research on the efficiency and friction modeling of gear pair systems has been carried out [1]–[4]. This research differs widely in terms of targeted applications and methodologies. Xu and Kahraman [1] proposed a computational model for the friction related mechanical efficiency losses of parallel axis gear pairs. The model incorporated a gear-load distribution model, a friction model and a mechanical efficiency formulation to predict the mechanical efficiency of a gear pair under typical operating, surface and lubricating conditions. The results from this study showed that the mechanical efficiency of a parallel axis gear pair falls in the range, 98%–99.5%. However, the study only considered the friction losses of a single gear pair.

Neil and Stuart [4] analyzed the effect of modified addendum, tooth thickness and gear center distance on the efficiency of non-standard and high contact ratio involute spur gears. The study considered sliding friction, rolling friction and windage losses and showed that despite their high sliding velocities, high contact ratio gears can be designed to levels of efficiencies comparable to conventional standard gears while retaining their advantages through proper selection of gear geometry.

Robert and Charles [5] performed an experimental and analytical comparison of the efficiency of high speed helical gear train at varying speeds and loads to 3730 kW and 15,000 rpm. The results from this study indicated that the operational

conditions of the gearing system affects the loss contributions of the various mechanisms and therefore the overall efficiency of the gear system.

Heingartner and Mba [6] presented a review of some of the mathematical models proposed for individual components associated with windage, churning, sliding and rolling friction losses and proposed a mathematical model to predict the power losses on helical gears highlighting the major contributor to losses in the gear mesh. The study showed that sliding frictional losses are heavily load dependent, increasing with load while the rolling friction losses decreased slightly with an increase in load.

The literature review presented in this study shows that a lot of focus has been put on single gear pairs and in most cases only sliding frictional losses were considered. The literature on the overall efficiency of multistage gear trains is limited and not readily available. This study therefore aims at providing an efficiency prediction model that can be used to predict the overall efficiency of a multistage gear train. The specific objectives of this study are as follows:

- 1) To incorporate power losses associated with windage, sliding friction and rolling friction in determining the overall efficiency of a multistage gear train.
- 2) To use a recently developed friction coefficient model [1] to predict instantaneous coefficient of friction and hence the sliding friction losses.
- 3) To develop a model for the prediction of the instantaneous overall efficiency of a multistage tractor gear gear train, including all gear, lubricant, surface finish related parameters and operating conditions.

## II. MODEL FORMULATION

The model developed in this investigation is based on a multistage tractor gearbox shown in Fig 1 and Fig 2 [7]. The gearbox has six forward speeds and two reverse speeds. Each gear train contains four reduction stages.

### A. Windage and Churning losses

Windage losses result from the lubricant being flung off the gear teeth as the gears rotate and the expulsion of the lubricant from the tooth spaces as the gears come into mesh [6]. Churning losses are defined as the action of the gears moving the lubricant inside the gear case. Dawson [8] conducted experimental tests of windage on a number of gear diameters, pitches, face width and environmental effects and an empirical formula based on these results was developed as shown in equation 1.

$$P_w = C_4 \cdot C \cdot \rho \cdot N^{2.85} D^{4.7} \nu^{0.15} \lambda \quad (1)$$

where,  $C_4$  is a constant ( $=1.12 \times 10^{-8}$ ),  $C$  is a constant that is dependent on the face width to diameter ratio,  $\rho$  is the density of the gear operational environment ( $\text{Kg/m}^3$ ),  $D$  is the pitch diameter of the gear (m),  $\nu$  is the kinematic viscosity of the lubricant ( $\text{m}^2/\text{s}$ ), and  $\lambda$  is a constant related to the type of housing surrounding the gear ( $\lambda = 1$  (open);  $= 0.7$  (loose enclosure);  $= 0.5$  (close enclosure)) [5].

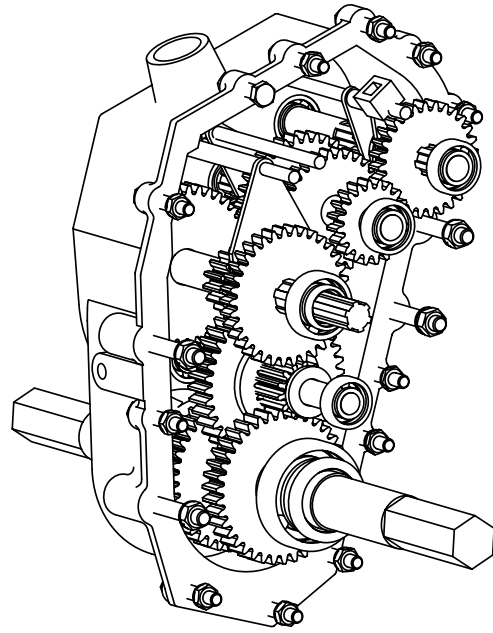

Fig. 1. Section of the multistage tractor gearbox

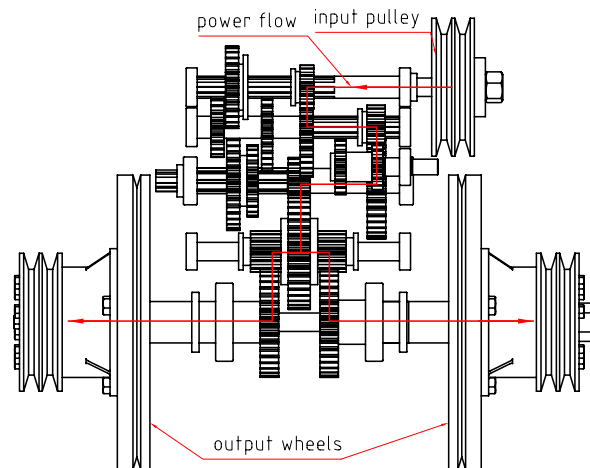

Fig. 2. An orthographic view of the gear train showing the power flow.

Fig 3 shows sample results from the components in this study based on the work of Dawson and using equation 1. It can be observed that the windage and churning losses increase with an increase in the rotating speed and the diameter of the gear. However, these losses are not significant for speeds below 1000 rpm.

### B. Rolling Friction Losses

Motion of the gears is achieved by rolling and sliding. The rolling friction loss is dependent on the instantaneous rolling velocity and the lubricant film thickness [6]. An elastohydrodynamic (EHD) lubricant film is developed between the gear

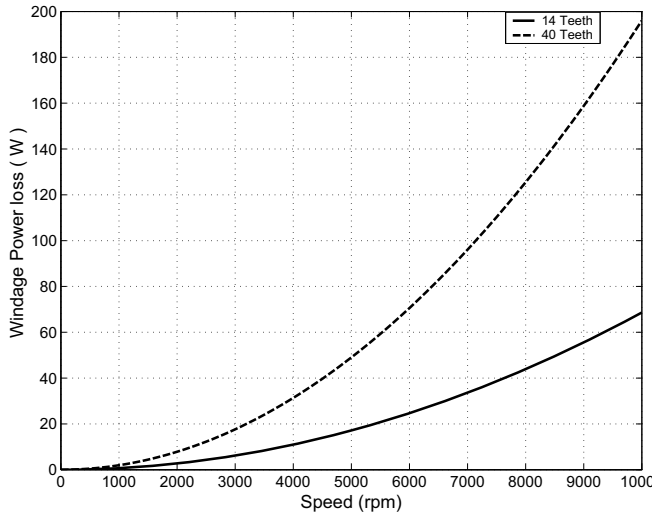

Fig. 3. Windage power loss as a function of speed for gears with a module of 3 mm

teeth as the teeth come into mesh and the rolling action of the gear teeth draw the lubricant into the contact zone [6]. The instantaneous force due to build up of the EHD lubricant film is given by equation 2 [4].

$$F_R(\theta) = C_1 h(\theta) \varphi_t F \quad (2)$$

where,  $C_1 = 9.0 \times 10^7$  and  $F$  is the face width. The gear contact film thickness  $h(\theta)$  is calculated by the method of Hamrock and Dawson (equation 3) which is detailed in [4].

$$h(\theta) = 2.69U^{0.67} G^{0.53} W_i(\theta)^{-0.067} (1 - 0.61e^{-0.73k}) \quad (3)$$

A thermal reduction factor,  $\varphi_t$  [9] is included in the expression for the rolling force to limit  $h(\theta)$  as the pitch-line velocity increases.  $W_i(\theta)$  (Fig 4) is the normal load on the gear tooth and varies along the path of contact due to the change in the number of teeth in contact and movement of the contact point.

The rolling power loss is given as [6]:

$$P_R = V_R(\theta) \cdot F_R(\theta) \quad (4)$$

Fig 4 shows the rolling friction power loss as a function of the contact position for the various meshes in the gear system. It can be observed that the rolling friction is periodic at the mesh period and reduces with increased load. This is due to the decreased film thickness with increased load.

### C. Sliding Friction Power Loss

Sliding friction is recognized as one of the main sources of power loss in gear systems. The free body diagram of an engaging spur gear pair is shown in Fig 6 where  $W_A$  and  $W_B$  denote the normal loads at contact points A and B respectively. The sliding friction on the gear teeth surface causes frictional force  $F_{SA} = \mu_A W_A$  and  $F_{SB} = \mu_B W_B$  along the off-line of action direction depending on the number of teeth in contact. The instantaneous sliding friction loss is a function of the

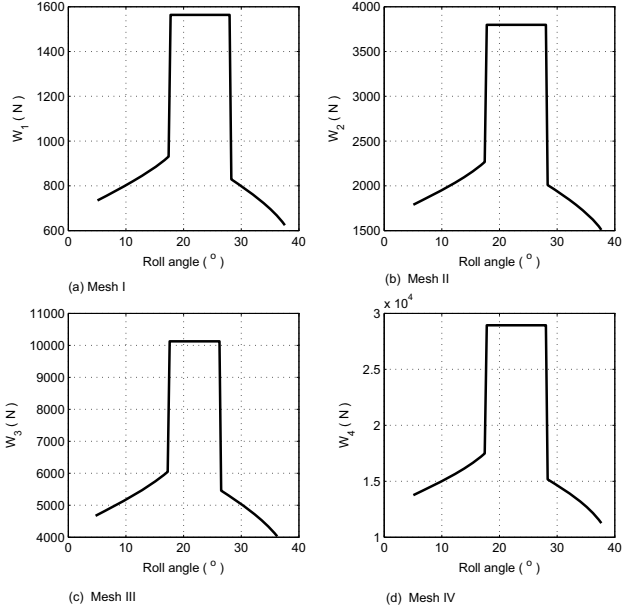

Fig. 4. Normal load on the gear tooth as a function of the contact position for the gear meshes

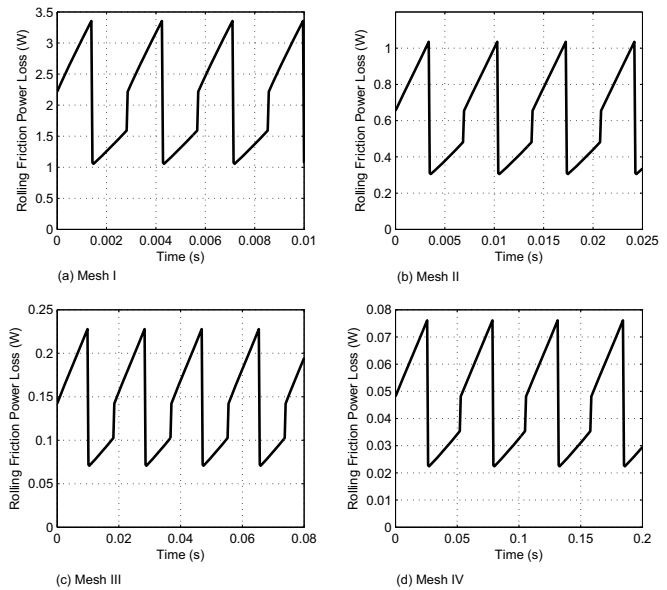

Fig. 5. Rolling friction power loss for the various meshes in the gear system

instantaneous sliding velocity and the friction force which is a function of the instantaneous normal load (Fig 4) and the instantaneous coefficient of friction.

The sliding velocity is a function of the contact position. It starts with a high velocity at the start of approach and reduces to zero at the pitch point, changes direction and increases again to a peak value at the end of the recess as shown in Fig 7.

Under EHL conditions, the friction coefficient is a function of the surface velocity, curvature, and the normal contact load  $W$  on the mating surfaces, such that  $\mu =$

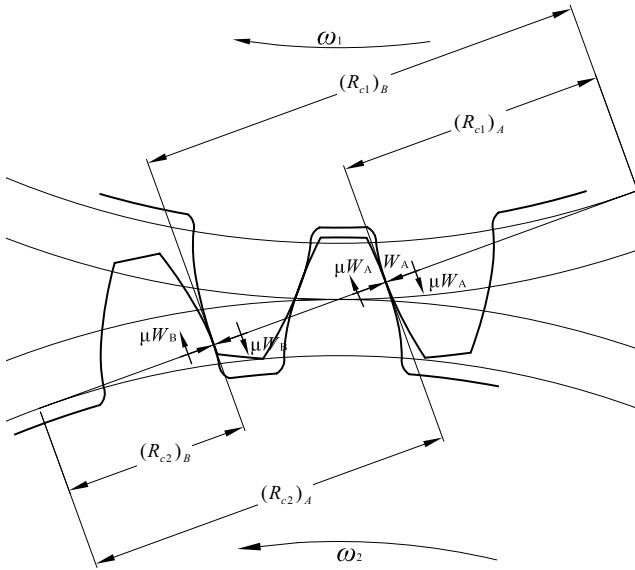

Fig. 6. Free body diagram of a meshing gear pair)

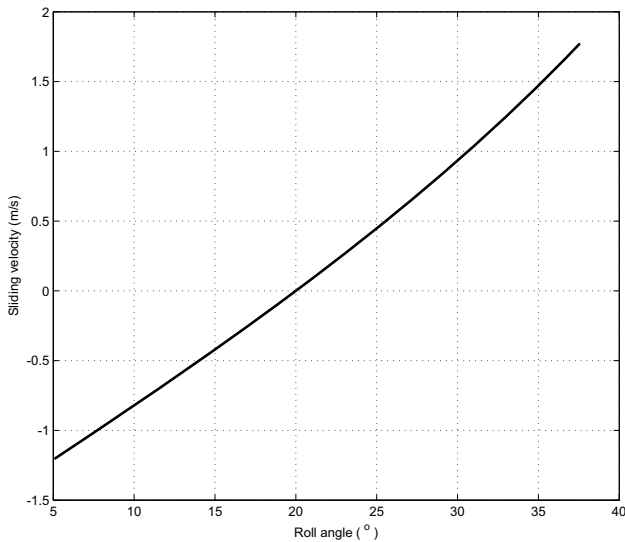

Fig. 7. Sliding velocity for a pair of gears in mesh (pinion, 14 teeth and gear, 40 teeth)

$f(V_s, W, V_R, T_l, R_c, \eta_o, \dots)$ . Here,  $V_R$  is the rolling velocity,  $\eta_o$  is the lubricant dynamic viscosity and  $T_l$  is the fluid inlet temperature [3]. Conversely, mixed lubrication condition is characterized by partial asperity contact and surface finish,  $S$  becomes an additional parameter influencing friction properties and thus  $\mu = f(V_s, W, V_R, T_l, R_c, \eta_o, S..)$  [3]. A large number of empirical formulae for determining the coefficient of friction can be found in reference [1], [3], [10], [11]. Most of these formulae are obtained by curve fitting measured data from experimental tests. They have the following general formula  $\mu = f(V_s, W, V_R, P_{max}, R_c, \eta_o, S..)$ , where  $P_{max}$  is the contact pressure.

In this study, an empirical formula developed by Xu and

Kahraman [1] was adopted as it was found to accurately model the instantaneous coefficient of friction along the path of contact of a pair of gears in mesh. This model is based on Electro-hydrodynamic lubrication (EHL) and was obtained by multiple linear regression analysis. This model includes the key parameters influencing friction at the contacting gear surfaces, namely sliding velocity, contacting pressure, surface roughness, lubricant dynamic viscosity, radius of curvature and entrainment velocity. The formula was found to correlate very well with experimental data [1]. The formula can therefore be used with confidence for the prediction of friction coefficient for a pair of contacting gears. This formula is written as:

$$\mu = e^{f(SR, P_h, \eta, S)} P_h^{b_2} |SR|^{b_3} V_e^{b_6} \eta^{b_7} R^{b_8} \quad (5)$$

where,

$$f(SR, P_h, \eta, S) = b_1 + b_4 |SR| P_h \log_{10}(\eta) + b_5 e^{-|SR| P_h \log_{10}(\eta) + b_9 e^S} \quad (6)$$

$$V_e = \frac{u_1 + u_2}{2}$$

$$V_r = u_1 + u_2$$

$$V_s = u_1 - u_2$$

$$SR = \frac{V_s}{V_e}$$

$$P_h = \sqrt{\frac{W' E'}{2\pi R}}$$

$$R = \frac{R_{c1} R_{c2}}{R_{c1} + R_{c2}}$$

$$E' = 2 \left[ \frac{1 - \nu_1}{E_1} + \frac{1 - \nu_2}{E_2} \right]^{-1}$$

The above set of equations were coded in a FORTRAN program and simulated. Fig 8 shows the variation of the coefficient of friction along the path of contact of the meshing gears for the various meshes in the gear system. As seen from Fig 8, the friction coefficient approached zero as the contact point nears the pitch point. This is because the rate of sliding decreases towards the pitch point, becomes zero at the pitch point, changes the direction and increases as the contact point moves away from the pitch point. The discontinuities in the friction coefficient curve show the points of transition from double pair contact to single pair contact and vice versa.

The instantaneous power loss is given by:

i. Double pair contact zone:

$$P_S(\theta) = \mu_A(\theta) W_A(\theta) V_{SA} + \mu_B(\theta) W_B(\theta) V_{SB} \quad (7)$$

ii. Single pair contact zone:

$$P_S(\theta) = \mu(\theta) W(\theta) V_S \quad (8)$$

The sliding friction loss is dependent on the position of contact during the meshing cycle as seen in Fig 9. The sliding loss reduces along the path of approach to zero at the pitch-point and then increases along the path of recess. The zones of single contact and double contact are clearly visible in all the plots. The analysis shows that the sliding friction contributes the largest percentage of the total power loss in a gear system as compared to the rolling and windage losses.

#### D. Overall Power Loss

The overall power loss was obtained by summing all the components of power loss in the system as shown in equations

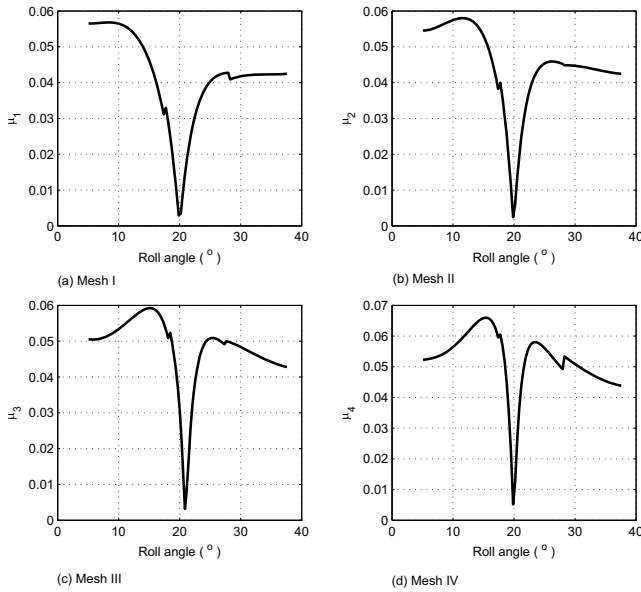

Fig. 8. Coefficient of friction based on the EHL model for the various gear meshes

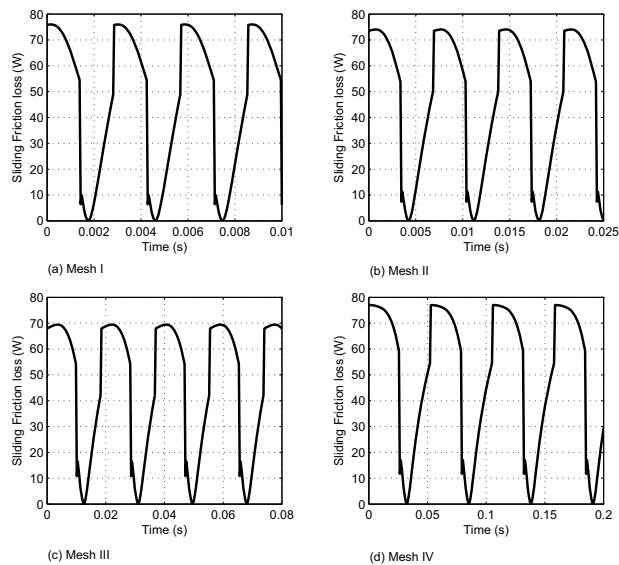

Fig. 9. Instantaneous sliding friction power loss for the various meshes

9-11. It was assumed that all the gear meshes are in phase at the beginning of the simulations.

$$P_W = \sum_j^m P_{Wj} \quad (9)$$

$$P_R(\theta) = \sum_i^n P_{Ri}(\theta) \quad (10)$$

$$P_S(\theta) = \sum_i^n P_{Si}(\theta) \quad (11)$$

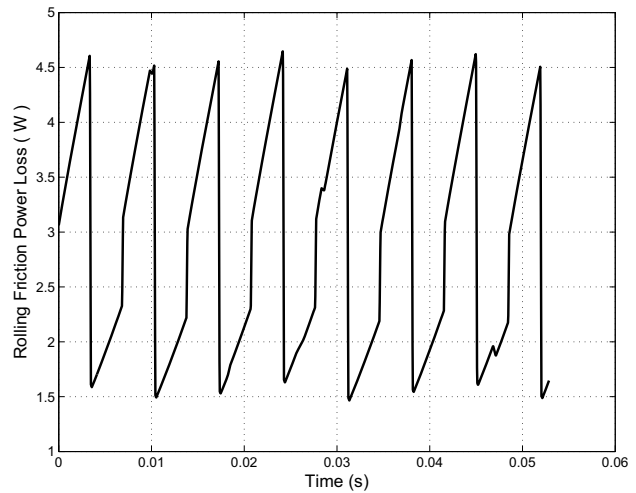

Fig. 10. Overall rolling friction loss in the gear system

$$P_O(\theta) = \sum_i^n P_{Ri}(\theta) + P_{Si}(\theta) + P_W \quad (12)$$

where,  $n = 4$  (number of meshes),  $m = 17$  (number of gear wheels)

In practice, the power loss will be a function of the angular rotation of the gear sets and this will only be known as a function of time if the mean rotational speed can be assumed to be (or approximated as) constant [12]. A cubic spline interpolation was employed in order to determine the magnitude of each component of power loss for each gear mesh at each point of contact as a function of time for one mesh period of the output gears [13]. Figs 10 and 13 show the overall power loss for the rolling and sliding friction loss referred to the output shafts. Fig 12 shows the overall power loss as a function of time referred to the output shafts while Fig 13 shows the overall efficiency as a function of time obtained using the equation 13. It can be seen that the efficiency ranges between 94% and 99.5%.

$$\% \eta_o = \frac{P_i - P_O(t)}{P_i} \quad (13)$$

where  $P_i$  is the input power.

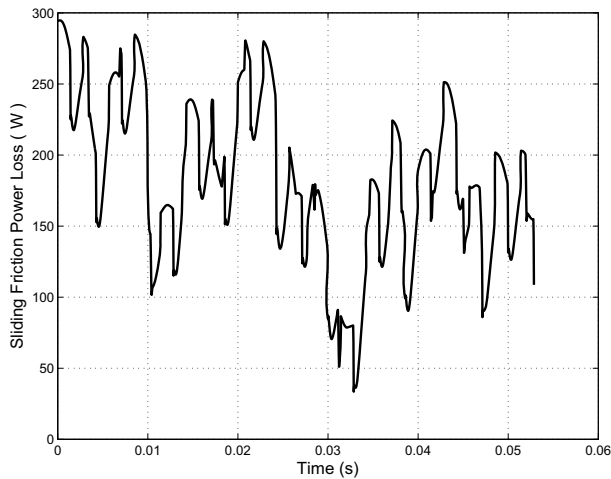

Fig. 11. Overall sliding friction loss in the system

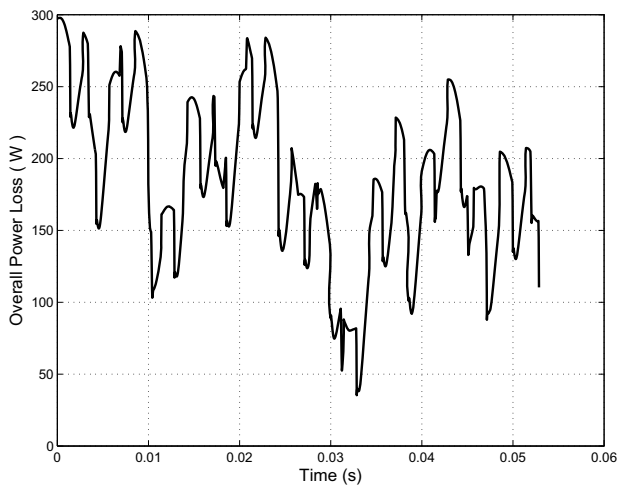

Fig. 12. Overall power loss in the system

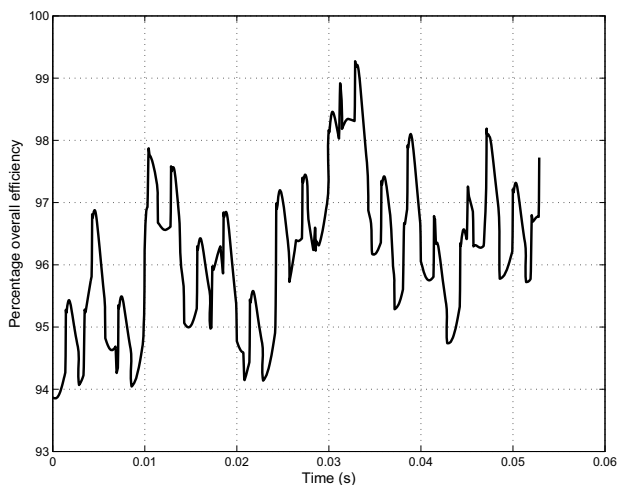

Fig. 13. Overall efficiency for the system

### III. CONCLUSION

A mathematical model was developed to predict the overall efficiency of a four-stage tractor gear train. The main components of power loss considered in the analysis were the windage loss, rolling friction loss and sliding friction loss. The analysis showed that the windage losses are highly dependent on the rotational speed of the gear wheels and is insignificant for speeds below 1000 rpm. The rolling friction loss was found to contribute a small percentage of the total power loss in the system. The rolling friction loss depend on the position of contact of the mating gear teeth and reduces with increased load. The sliding friction loss was found to contribute the largest portion of the overall power loss accounting for about 98% of the total power loss in the system. The overall efficiency for the system was found to be a function of time and ranged between 94% and 99% with an average efficiency of 96.16%. Determining the overall efficiency of a gear system is the first step in improving the efficiency of the system. One way to conduct efficiency improvements is to carry out analysis on the effect of gear design parameters, lubricant properties and housing arrangement on the efficiency of the gear system.

### APPENDIX

TABLE I

OPERATING CONDITIONS AND GEAR PARAMETERS FOR THE GEAR TRAIN

Input speed	1500 rpm
Input Power	4847 W
module ( $m$ )	3 mm
Pressure angle	$20^\circ$
E (alloy steel)	206 GPa
$\nu$ (alloy steel)	0.3
S	$0.7\mu\text{m}$

TABLE II

LUBRICANT PROPERTIES

SAE Grade	75W-140
Density $\rho$	$872\text{ Kg/m}^3$
kinematic viscosity $\nu$ at $40^\circ\text{C}$	$250\text{ mm}^2/\text{s}$
kinematic viscosity $\nu$ at $100^\circ\text{C}$	$30\text{ mm}^2/\text{s}$

### REFERENCES

- [1] H. Xu and A. Kahraman, "Prediction of Mechanical Efficiency of Parallel - Axis Gear Pairs," *Transactions of ASME*, vol. 129, pp. 58–68, 2007.
- [2] J. H. Kuang and A. D. Lin, "The Effect of Tooth Wear on the Vibration Spectrum of a Spur Gear Pair," *Journal of Vibrations and Acoustics*, vol. 123, pp. 311–317, 2001.
- [3] M. Vaishya and R. Singh, "Strategies for Modeling Friction in Gear Dynamics," *Journal of Mechanical Design*, vol. 125, pp. 383–393, 2003.
- [4] N. E. Anderson and S. H. Loewenthal, "Efficiency of Non-Standard High Contact Ratio Involute SpurGears," Tech Rep., NASA Lewis Research Center, 1984.
- [5] R. F. Handschuh and C. J. Kilmain, "Preliminary comparison of experimental and analytical efficiency results of high-speed helical gear trains," Tech. Rep., NASA Lewis Research Center, 2003.
- [6] P. Heingartner and D. Mba, "Determining Power Losses in the Helical Gear Mesh," *Gear Technology*, pp. 32–37, 2005.
- [7] J. K. Kimotho, "Modeling and simulation of vibrations of a multistage tractor gearbox," Master's thesis, Jomo Kenyatta University of Agriculture and Technology, 2008.

- [8] P. Dawson, "High speed gear windage," *GEC Review*, vol. 4, no. 3, pp. 164–167, 1988.
- [9] H. Cheng, "Isothermal elastohydrodynamic theory for the full range of pressure-viscosity coefficient," Tech. Rep., NASA Lewis Research Center, 1971.
- [10] H. Xu, *Development of a generalized Mechanical Efficiency Prediction Methodology for Gear Pairs*. Phd Thesis, The Ohio State University, 2005.
- [11] Hsiang-Hsi Lin, *Computer - Aided Design and Analysis of Spur Gear Dynamics*. PhD Thesis, University of Cincinnati, 1985.
- [12] K. G. Sejoong Oh and J. R. Barber, "Energy Conserving Equations of Motion for Gear Systems," *Journal of Vibrations and Acoustics, Transactions of ASME*, vol. 127, pp. 208–212, 2005.
- [13] James Kuria and John Kihui, "Modeling parametric vibration of multistage gear systems as a tool for design optimization," *International Journal of Mechanical, Industrial and Aerospace Engineering*, vol. 2, no. 3, pp. 159 – 166, 2008.