

Position Control of an AC Servo Motor Using VHDL & FPGA

Kariyappa B. S., Hariprasad S. A., and R. Nagaraj

Abstract—In this paper, a new method of controlling position of AC Servomotor using Field Programmable Gate Array (FPGA). FPGA controller is used to generate direction and the number of pulses required to rotate for a given angle. Pulses are sent as a square wave, the number of pulses determines the angle of rotation and frequency of square wave determines the speed of rotation. The proposed control scheme has been realized using XILINX FPGA SPARTAN XC3S400 and tested using MUMA012PIS model Alternating Current (AC) servomotor. Experimental results show that the position of the AC Servo motor can be controlled effectively.

Keywords—Alternating Current (AC), Field Programmable Gate Array (FPGA), Liquid Crystal Display (LCD).

I. INTRODUCTION

A servo motor is an Electro-mechanical device in which the electrical input determines the position of the armature of a motor. The shaft of the servo motor can be positioned to a specific angle by sending the coded signal. The AC servo motors have been widely used in the industrial fields and various approaches have been made to realize high performance motion control. These can be effectively utilized in many position control systems subjected to external disturbances such as friction.

With successively improving reliability and performance of digital controllers, the digital control techniques have predominated over other analog counter parts. The advantages of digital controllers are:

- Reconfigurability
- Power saving options
- Less external passive components
- Less sensitive to temperature variation
- High efficiency

Micro-processor based control scheme have the advantages of flexibility, higher reliability and lower cost, but the demanding control requirements of modern power conditioning systems will overload most general purpose micro-processors and the computing speed of microprocessor limits the use of microprocessor in complex algorithms.

Digital Signal Processors (DSPs) and Microcontrollers are used for digital control applications. But DSPs and

Microcontrollers can no longer keep pace with the new generation of applications that require not just higher performance also more flexible without increasing cost and resources.

Further microprocessors, Microcontrollers and DSPs are sequential machines that mean tasks are executed sequentially which takes longer processing time to accomplish the same task.

The high speed hard wired logic can enhance the computation capability. The ASIC based technology provides a rapid and low cost solution for special applications with large market. Owing to the progress of technology, the life cycle of most modern electronic products become shorter than their design cycle. The emergence of FPGA has drawn much attention due to its shorter design cycle, lower cost and higher density [1]. The simplicity and programmability of FPGA make it the most favorable choice for prototyping digital systems [2].

Different methods are used to control the position of AC servo motor. The Kalman filter is used to estimate the instantaneous speed and position with low precision [3]. Disturbance suppresser is used in Robust position control scheme for AC servo motors [4]. In Wrap digital position control around analog servos [5], the Microcontroller is used to control position and to send the motion commands to the analog servo controllers. The Neural networks and Fuzzy logic control systems are also used to control the position of AC servo motors.

In this paper a new method of controlling position of AC servo motor using FPGA is proposed.

II. FPGA BASED CONTROL SCHEME

Fig. 2 shows the proposed block diagram of the system. It mainly consists of keyboard, FPGA Controller, Driver and Motor.

A. Keyboard

The required angle is divided by 0.9 to get equivalent number; this number is entered as input through keyboard. it accepts decimal number as input. The keyboard consist of 4 columns and 4 rows, there are 16 keys from 0,1,2,3,4,5,6,7,8,9 and hex value A,B,C and D, a backspace and an enter. All keys are active low. i.e., when a key is pressed then the corresponding output is active low.

To find the position of the key pressed the columns are individually activated by sending high signal and the rows are

Kariyappa B. S. and Hariprasad S. A. are with ECE Department, R V College of Engineering, Bangalore-59, India (e-mail: kariyappabs@yahoo.com).

R. Nagaraj is with Center for Cognitive Technologies, RVCE Campus, Bangalore-59, India.

scanned. If there is a low signal in that row the corresponding row and column are linked and then key is detected. The structure of keyboard matrix is shown in Fig. 1.

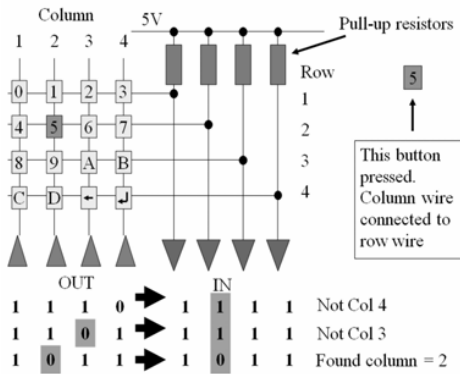

Fig. 1 Keyboard Matrix

B. Liquid Crystal Display (LCD)

LCD is used to display three values, one is the input data entered through keyboard, second is the number of pulses to be send to the driver and the third one is the direction of motor. The 16X2 LCD is used, which contains two lines and 16 characters in each line. It is a general purpose alphanumeric display.

C. FPGA Controller

FPGA Controller accepts input from the keyboard and it keeps track of the motor position within the controller. For this purpose the motor position is taken to be zero when the controller is reset and there after the position is tracked until the next reset. The flowchart is shown in Fig.3.

Based on the current position of the motor and given angle the controller calculates direction and the number of pulses to be send to the driver such that the motor can reach the destination with shortest distance between the current and desired position.

D. Driver Circuit

The Driver circuit gives the required current drive to the motor and it takes both speed and position feedback from the motor. The driver circuit sends commands to the servo motor based on the direction and the pulses from the controller.

The motor rotates in clockwise direction when direction signal is logic 0 and in anticlockwise direction when direction signal is logic 1. The motor can be configured for either velocity control or position control.

The motor takes 1000 pulses to rotate 360 degrees. For a rotation of 1 degree 2.78 pulses are required, however fraction of a pulse is ambiguous. So the motor is made to rotate in steps of 1.8 degrees which requires 5 pulses $((1000*1.8)/360=5)$. The input is entered in steps of 0.9 degrees as pulses.

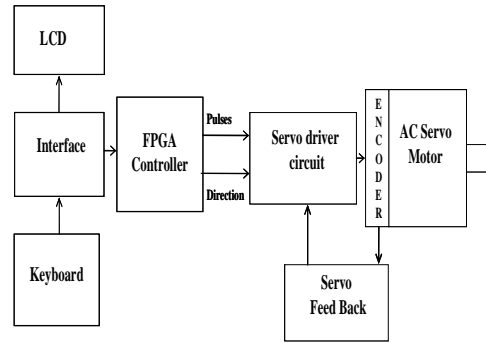

Fig. 2 Blockdiagram of proposed system

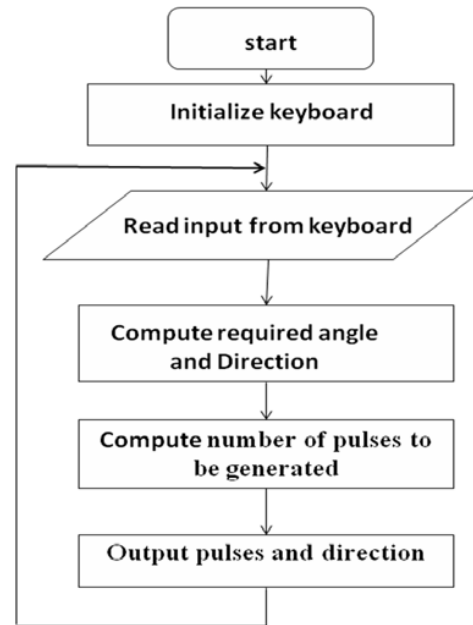
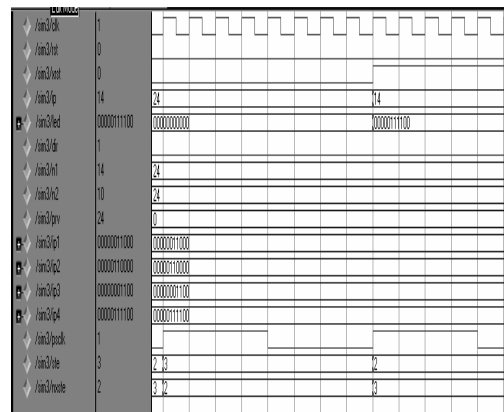
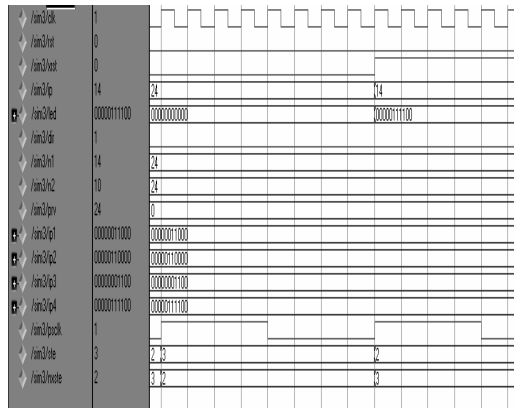

Fig. 3 Flow chart



(a) Previous I/p less than present I/p and Diff is less than 200



(b) Previous I/p less than present I/p and Diff is greater than 200

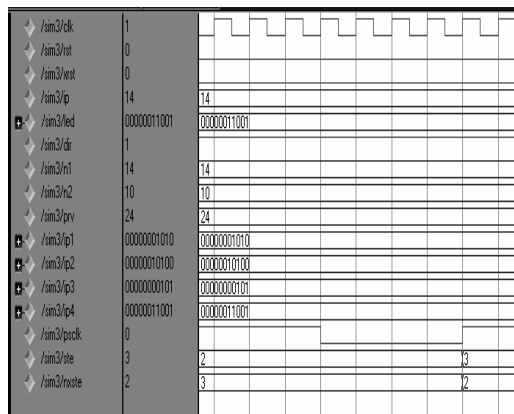

(c) Previous I/p greater than present I/p and Diff is less than 200

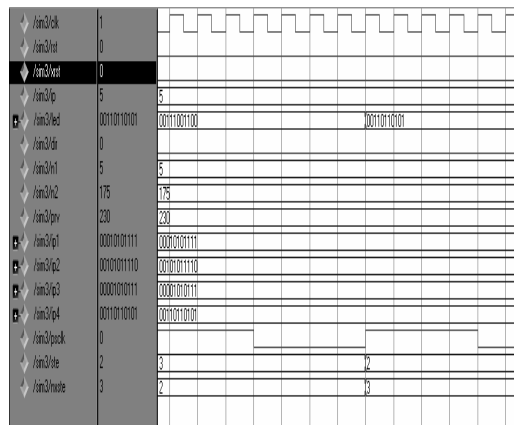

(d) Previous I/p greater than present I/p and Diff is greater than 200

Fig. 4 Simulation waveforms for different inputs

The simulation results for different inputs are shown in Fig. 4. When the previous input is less than present input and the difference is less than 200 then the direction is 0 (Clockwise) and the number of pulses are difference multiplied by 2.5. This is shown in Fig. 4(a). The Fig. 4(b), Fig. 4(c) and Fig. 4(d) shows for different cases of inputs where the previous input is less than or greater than the present input and the difference is less than or greater than 200. The difference is subtracted from 400 when it is greater than 200.

The motor reaches the required position in one of the direction (clockwise or anticlockwise) that takes less possible time. The Experimental setup is shown in Fig. 5.

The motor rotations in degrees for few inputs are shown in Table I. The result shows that the motor rotates with the minimum of 0 % error to maximum of 8%. The maximum error can be reduced to 1% if we consider the motor that takes 3600 pulses to rotate 360 degrees.

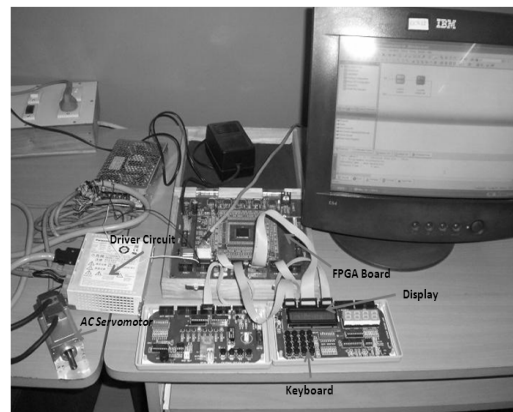

Fig. 5 Experimental setup

TABLE I
MOTOR POSITIONS FOR DIFFERENT INPUTS

Sl no.	Angle (°) (0-360)	input through keyboard (angle 0.9)	Previous input	Present input	Diff	Diff*2.5	Direction	Motor rot° from current position (°)	Motor rot° from reference point (°)
1.	0	0	0	0	0	0	0	0	0
2.	22	24	0	24	24	60	0	21.6	21.7
3	13	14	24	14	10	25	1	09	12.7
4	207	230	14	230	184	460	1	165.6	207.2
5	05	05	230	05	175	437	0	157.32	4.32

III. RESULTS AND CONCLUSION

The written code is simulated using Modelsim® and this code is downloaded into XILINX SPARTAN 3 XC3S400 FPGA Board.

REFERENCES

- [1] J C G Piementel and Hoang le-Hny, "A VHDL-based methodology to develop high performance servo drivers", IEEE 0-7803-6401-5/00.
- [2] Eric Monmasson and Marcian N cirstea "FPGA Design methodology for industrial control systems- A Review", IEEE trans on industrial electronics vol-54,no.-4,AUG-2007.
- [3] Heui-Wook Kim, Jong-Woo Choi, Seung-Ki SUI, "Accurate Position Control for AC Servo Motor using Novel Speed Estimator" 0-7803-3026-9/95, 1995 IEEE.
- [4] Joon Hyuk Kang, Chung Hyuk Yim, and Dong Il Kim, "Robust Position Control of AC Servo Motors" 0-7803-3026-9/95 1995 IEEE.
- [5] Sven Behnke and Michael Schreiber "Digital Position Control for Analog Servos" Proceedings,IEEE-RAS,Italy,Dec-06.
- [6] E. Monmasson, and Y.A. Chapuis "Contributions of FPGAs to the Control of Electrical Systems, a Review" IEEE Industrial Electronics Society Newsletter ISSN 0746-1240 VOL. 49, NO. 4 2002.
- [7] Dongmei Yu, Qingding Guo and Qing Hu" Position Control of Linear Servo System Using Intelligent Feedback Controller" International Conference on Intelligent Systems Design and Applications (ISDA'06) 0-7695-2528-8/06 © 2006.



B. S. Kariyappa is pursuing his PhD in the field of power Controllers. He obtained his Masters degree in Electronics & Communication Engineering from Bangalore University and BE in Electronics & Communication Engineering from Bangalore University. His research interests are VLSI & VHDL and power controllers. He has published papers at various journals and International conference. He is a member of ISTE, IETE.



member of ISTE, IETE.

S. A. Hariprasad is pursuing PhD in power controller area. He obtained his Masters degree in Electronics & Communication Engineering from Bangalore University and BE degree in Electronics & Communication Engineering from Mysore University. His research interests are Embedded Systems, power controller and Microwave. He has published papers at various journals and International conference. He is a



R. Nagaraj is the Director, at R.V. Centre for Cognitive Technologies. He has obtained doctoral degree from the Visvesvaraya Technological University for a thesis on Automatic Flight Control. He obtained his Masters degree in Power Electronics from Gulbarga University and BE in Electronics from Bangalore University. His research interests are Aerospace Electronics, Industrial Electronics and DSP. He has guided more than 30 undergraduate projects. He is also guiding a couple of Ph.D scholars. He has several ongoing Research Projects under his supervision. Dr. Nagaraj has published several technical papers in International Refereed Journals & Conferences.