

Plasma Properties Effect on Fluorescent Tube Plasma Antenna Performance

A. N. Dagang, E. I. Ismail, Z. Zakaria

Abstract—This paper presents the analysis on the performance of monopole antenna with fluorescent tubes. In this research, the simulation and experimental approach is conducted. The fluorescent tube with different length and size is designed using Computer Simulation Technology (CST) software and the characteristics of antenna parameter are simulated throughout the software. CST was used to simulate antenna parameters such as return loss, resonant frequency, gain and directivity. Vector Network Analyzer (VNA) was used to measure the return loss of plasma antenna in order to validate the simulation results. In the simulation and experiment, the supply frequency is set starting from 1 GHz to 10 GHz. The results show that the return loss of plasma antenna changes when size of fluorescent tubes is varied, correspond to the different plasma properties. It shows that different values of plasma properties such as plasma frequency and collision frequency gives difference result of return loss, gain and directivity. For the gain, the values range from 2.14 dB to 2.36 dB. The return loss of plasma antenna offers higher value range from -22.187 dB to -32.903 dB. The higher the values of plasma frequency and collision frequency, the higher return loss can be obtained. The values obtained are comparative to the conventional type of metal antenna.

Keywords—Plasma antenna, fluorescent tube, computer simulation technology, plasma parameters.

I. INTRODUCTION

RECENTLY, there has been a growing interest in plasma antenna due to their intriguing properties and numerous advantages over metallic antenna. Since plasma antenna is one of the antenna in which the material conducting element of metal is replaced by plasma, it is able to radiate electromagnetic wave from the radiator. This plasma antenna uses gas in sealing tubes discharge by high voltage. As the tube is induced with electrical energy, the gas inside the tube will be excited, ionized and turn into plasma state, where it becomes conductive and capable to transmit and receive radio signals [1]. Besides, plasma can easily be generated using various methods such as by AC or DC supply, microwave or radio frequency discharge, and electron beam generated plasma or simply using commercial fluorescence tube. The application of plasma physics in wireless communication technology has attracted many researchers due to its possibility and flexibility as a good conductance material. The previous research on plasma antennas has shown that the

plasma antenna is just as effective as a metal antenna [2], [3]. Plasma antenna uses partially or fully ionized gas instead of metal as the conducting medium to create an antenna. Plasma antenna is a type of antenna in which the solid metal conducting elements being replaced by moving neutral particles and ions that formed plasma state. Plasma antenna uses the ionized gas as a conductive medium as a substitute of a metal to transmit, receive or reflect the electromagnetic signal for radar, stealth or, communication purpose [3], [4]. The plasma antenna also has a gift to get reconstructed with different electron density and collision frequency.

Nowadays, many researchers have successfully developed the plasma whether in theoretical, or in experimental [1]-[3]. Some of them have demonstrated the transmission and reception of operating plasma antennas over a wide frequency range (500 MHz - 20 GHz) [5], [6]. Many works on plasma antenna have been done before, and from the research, it shows that plasma antenna is as effective as a metal antenna where the length of the plasma column increases relatively to the square root of the applied electrical power [3], [5]. According to Zhu et al., the changing of variable parameters of plasma antenna will lead to the changing in its radiation pattern. Numbers of fundamental properties of the plasma antenna have been studied, and important results are obtained where some of them significantly demonstrate the characteristics of plasma as an antenna [7]. Most of the researches are concentrated on antenna parameters rather than plasma parameters that influence the antenna performance. Plasma monopole antenna is the most basic type of antenna with plasma radiator concept. Plasma can be considered as a type of dispersion material, hence the impedance and radiation characteristics produced by the plasma monopole antenna are different compared to metal antenna [8]-[10].

This research is focusing on the simulation and the results obtained are verified through experiment. The plasma tube or fluorescent lamp with different length and size is design and simulated by using CST software. The characteristics of antenna parameters are determined experimentally by using VNA. In this study, plasma column is used as antenna and it is interesting to explore on the plasma properties such as plasma frequency and collision frequency that can be controlled via electrical input, consequently can influence antenna parameters such as frequency, return loss, gain and directivity. The focus of the study is to determine how the dimension of plasma tube could affect the plasma properties and subsequently change the plasma antenna performance.

A. N. Dagang is with the School of Ocean Engineering, Universiti Malaysia Terengganu, 21030 Kuala Terengganu, Malaysia (phone: 60-9-6683440; fax: 60-9-6683991; e-mail: nazri.dagang@umt.edu.my).

E. I. Ismail was with School of Ocean Engineering, Universiti Malaysia Terengganu, 21030 Kuala Terengganu, Malaysia.

Z. Zakaria is with the Faculty of Electronics and Computer Engineering, Universiti Teknikal Malaysia Melaka, 76100 Melaka, Malaysia.

II. PLASMA PROPERTIES SETUP

Plasma properties such as electron density, electron temperature, collision frequency and plasma frequency can be determined using simulation and calculation. In order to obtain those values, discharge tube need to be ignited and electrical discharge parameters such as current and voltage need to be measured. The values of plasma parameters obtained here can be used in CST software to simulate antenna parameters.

A. Plasma Tube (Fluorescent Lamp)

Commercially available fluorescent lamps were used as plasma tube working as monopole plasma antenna. The fluorescent tube is assumed to be filled with a mixture of argon and mercury (Ar-Hg) vapor at 10 Torr as what commercial fluorescent normally contented. Four different dimensions of tubes were used as shown in Table I.

TABLE I
DIMENSIONS OF FLUORESCENT TUBE

Tube Label	Length (mm)	Diameter (mm)
A	28.5	1.59
B	21.0	1.59
C	13.4	1.59
D	31.7	1.27

B. Electrical Properties

Electrical properties need to be measured in order to calculate electron density, electron temperature, plasma frequency, and collision frequency. With applying enough voltage at the two sides of electrodes, the gas can be ionized. The fluorescent lamp was lighted up using AC discharge through electronics ballast and electrical properties such as input current and voltage will be measured by using voltage and current probes. The measured value of voltage and current were recorded for the use of calculation of electron temperature and electron density in Glomac programming.

C. Glomac Programming

Glomac programming developed by Lister and Coe [11] was used to calculate the plasma parameter which explains the behavior of plasma in the discharge tube. It is a Fortran-based program and a one dimensional numerical model, developed specifically to model a positive column low-pressure mercury-rare gas discharges. In the experiment, discharge tubes which contain low-pressure mercury and rare gas have been used the same model that has been applied in Glomac. Table II shows an example of values needed to run Glomac programming. This numerical model allowed us to obtain plasma properties based on main measurable parameters below:

- Dimension of discharge tube (thickness and length).
- Length of PC-positive column (distance between electrodes).
- Discharge current (current applied to the lamp).
- Filling gas and pressure
- Cathode fall voltage (voltage difference between input voltage and voltage at positive column).

TABLE II
EXAMPLE OF DEFAULT VALUES OF DISCHARGE PARAMETERS

Parameters	Default
Type of gas	Mix Argon (Ar) and Mercury (Hg)
Gas pressure, P (Torr)	10
Tube radius, r (cm)	0.8
Discharge current, I (A)	0.03
Positive column length, l (cm)	16
Gas fill temperature, ($^{\circ}\text{C}$)	25
Wall axis temperature, ($^{\circ}\text{C}$)	30

D. Plasma Properties

Plasma characteristics such as collision frequency and plasma frequency are obtained in order to simulate the behavior of plasma that will be used in CST software. Plasma frequency, ω_p , is calculated by using (1) (where n_e is the density of the ionized electrons, e and m is electron charge and electron mass respectively), while collision frequency, ν_c , can be obtained using (2) (where n is gas density, σ is collision cross section and v_e is electron speed.). Numerically, the plasma frequency is based on the electron number density and collision frequency is related to the electron temperature that obtained from Glomac programming. From the calculation, the values of plasma frequency and collision frequency were obtained and used as input parameters in CST software for plasma antenna.

$$\omega_p = \sqrt{\frac{e^2 n_e}{\epsilon_0 m}} \quad (1)$$

$$\nu_c = n \langle \sigma v_e \rangle \quad (2)$$

III. ANTENNA PARAMETERS

The plasma antennas were designed according to dimension shown in Table II. In the CST software, the behavior of plasma is given by a Drude dispersion model which describes the transport properties of electrons in materials especially metals. The plasma frequency, ω_p and the collision frequency, ν_c are the so called Drude parameters. The signal can be transmitted or received using coupling sleeve connected to the SMA connector.

A. CST Antenna Design

The monopole plasma antenna with different length of fluorescent tube was designed by using CST software. Fig. 1 illustrates the design of the monopole plasma antenna in the CST software. The antenna is fed by a standard SMA connector that is located at 3 cm from the bottom of the discharge tube and connected with 4-turn of copper foil coupling sleeve. The coupling sleeve acted as an input terminal which is used to connect the fluorescent tube with external signals and measuring equipment. Besides it also served as capacitor which stored the electrical charge and resisted any voltage across it. With the help of coupling sleeve, the plasma column behaves as a conductor and used as antenna [3]. The SMA connector design is according to

specification in. The coupling sleeve on the tube represents as capacitor which is stored electrical charge and resisted any voltage across it. In CST software, the Drude model was used for creating the plasma material which is the plasma frequency and collision frequency as Drude parameters. By calculation, the collision frequency is set at $1.9764 \times 10^9 \text{ s}^{-1}$, meanwhile the plasma frequency is set at $1.9131 \times 10^{10} \text{ rad/s}$ respectively.

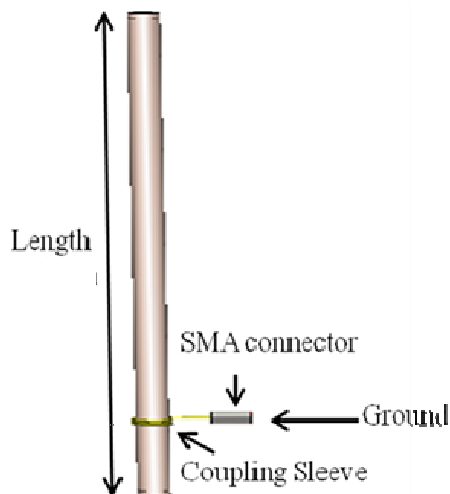

Fig. 1 Basic design of the monopole plasma antenna

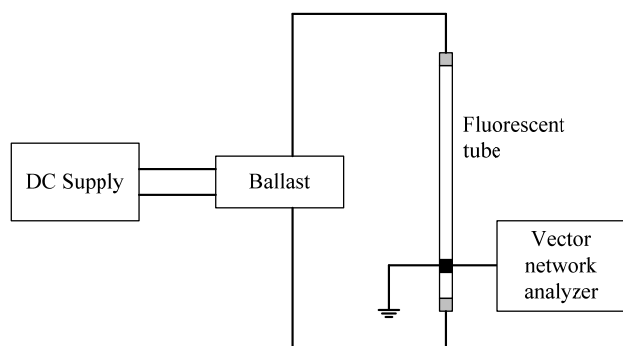

Fig. 2 Experimental setup for return loss measurement

B. Experimental Setup

An experimental setup as shown in Fig. 2 is assembled to measure the return loss characteristics of the constructed plasma antenna. The type of VNA used is Agilent Technologies (N5242A PNA-X). The plasma antenna is constructed using the Ar-Hg (10 Torr) fluorescent tube and was energized by using power supply range from 200 to 400 V and input current range from 30 to 40 mA. When energized, the plasma column became highly conductive and can be used as an antenna. The fluorescent tube is also mounted with 4-turn copper coil, known as coupling sleeve. The coupling sleeve is positioned 3 cm from the lower end of the tube. This coupling sleeve is connected to a SMA connector that is attached at the aluminum box which acts as ground plate. Then, SMA connector is connected to VNA. In addition, the aluminum box is built as stand for the fluorescent tube and as a ground.

Return loss measurements were done in the frequency range from 1 GHz to 10 GHz after standard calibration process was applied. To avoid the destruction of VNA to high voltage flow, the DC voltage block connector was also connected to VNA. The function of DC block is the ability to block voltage until 3 kV.

IV. RESULTS AND DISCUSSION

The characteristics of both from plasma and antenna aspect were studied. Electrical characteristics study led to the understanding on plasma behavior inside the tubes. CST simulation was run using calculated electron and plasma frequencies, and from that antenna parameters such as return loss, resonant frequency, bandwidth, gain and radiation pattern were obtained. Return loss and resonant frequency can be compared with the experimental results.

A. Effect of Tube Dimension on Plasma Parameters

The electron temperature and electron density are one of the important parameters to get the value of plasma frequency and collision frequency. The data have been calculated by Glomac programming. In this study, the gas pressure for all of the fluorescent tube is assumed to be the same which is Ar-Hg 10 Torr. Therefore, the different of electron temperature and electron density of the fluorescent tube are different from each other based on their length and diameter. The changes of electron density and temperature are shown in Table III. The electron density and the electron temperature are higher, when the longer length of fluorescent tube is used in the experiment. This can be considered due to when the longer length of fluorescent tube was used, the higher the value of electron produced from the ionization thus will increase the electron temperature.

TABLE III
THE ELECTRON TEMPERATURE AND ELECTRON DENSITY BASED ON DIFFERENT SIZE OF FLUORESCENT TUBES

Tube Label	Ar-Hg (10 Torr)	
	Electron Temperature T_e (eV)	Electron Density n_e (m^{-3})
A	0.964	1.15×10^{17}
B	0.959	1.78×10^{17}
C	0.966	9.38×10^{16}
D	1.022	2.07×10^{17}

TABLE IV
THE PLASMA FREQUENCY AND COLLISION FREQUENCY FOR EACH TUBE

Tube Label	Ar-Hg (10 Torr)	
	Plasma Frequency ω_p (rad/s)	Collision Frequency ν_c (1/s)
A	1.9131×10^{10}	1.9764×10^9
B	2.3801×10^{10}	1.971×10^9
C	1.0525×10^{10}	1.9785×10^9
D	2.567×10^{10}	2.0149×10^9

The plasma frequency and collision frequency of Ar-Hg (10 Torr) fluorescent tubes were calculated using (1) and (2) and shown in Table IV. In terms of different length of fluorescent tube, the plasma frequency and collision frequency for longer

length is higher compared to the shorter length. This might be due to the electron mobility in a longer length tubes. The longer the length of fluorescent tube, the higher the collision of electron in the tube, thus will increase the collision frequency. When the collision frequency is high, the value of plasma frequency also increases due to the high volume of plasma produced.

B. Effect of Plasma Parameters on Antenna Performance

Different size of tubes gives different plasma properties. Due to these differences, the antenna parameters are expected to have difference performance especially in terms of return loss, gain and directivity. In this study, the number turns of coupling sleeve is kept at 4-turn in order to have same condition for all tubes. From the results show in Table V and Fig. 3, the highest return loss for 4-turn coupling sleeve is at the lowest length of 13.4 cm. The return loss is -32.574 dB at frequency of 3.430 GHz. For the length of 28.5 cm and 21.0 cm, the return loss at 4-turn of coupling sleeve is -31.108 dB and -32.570 dB at the same frequency. The lowest value for return loss is -19.777 dB which at the highest length of 31.7 cm. The highest value of gain at 4 coupling sleeve is at the length of 28.5 cm which is 2.346 dB at frequency of 3.430 GHz. It is slightly higher compared to the value of gain at 2 coupling sleeve. At the same frequency, the length of 21.0 cm and 13.4 cm has the gain value of 2.275 dB and 2.226 dB. Meanwhile, the value of gain for the longest length at frequency of 3.682 GHz is 2.269 dB. The research and analysis of the monopole plasma antenna demonstrate that changing of parameters of plasma antenna can lead to changing of return loss and gain of it [6]. Thus, the gain and directivity of plasma antenna can be promoted by changing the inner size of tube to smaller size.

Results for antenna parameters with difference tube diameter are shown in Table VI and Fig. 4. From the results, for two different diameters of fluorescent tube, the highest return loss is at the bigger diameter which is 15.9 mm compared to 12.7 mm. In terms of gain, for diameter 15.9 mm is 2.346 dB while at diameter 12.7 mm is 2.269 dB. It can be considered that the diameter size give an effect to antenna parameters and consequently to antenna performance. When the bigger tube diameter is used, the plasma density is higher and the antenna gain increases. This can be thought due to the size of plasma column has been increased which increases the electron movement and conductivity, and lead to a significant effect to the antenna performance.

TABLE V
ANTENNA PARAMETERS RESULTS BASED ON DIFFERENT LENGTH OF
FLUORESCENT TUBE

Tube Label (length)	Ar-Hg (10 Torr)			
	Frequency (GHz)	Return Loss (dB)	Gain (dB)	Directivity (dBi)
A (28.5 mm)	3.430	-31.108	2.346	2.393
B (21.0 mm)	3.430	-32.570	2.275	2.406
C (13.4 mm)	3.430	-32.574	2.226	2.409
D (31.7 mm)	3.682	-19.777	2.269	2.410

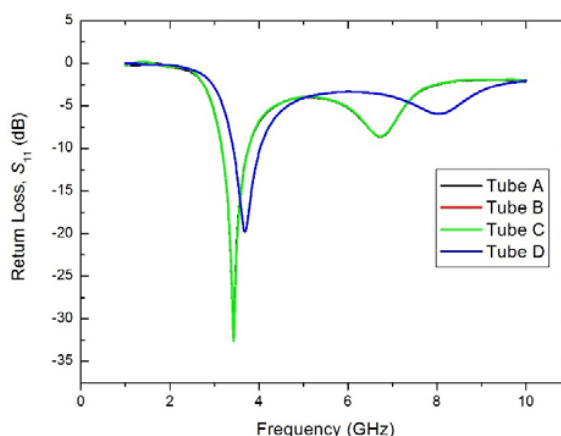

Fig. 3 Return loss for each tube based on different length

TABLE VI
ANTENNA PARAMETERS RESULTS BASED ON DIFFERENT DIAMETER OF
FLUORESCENT TUBE

Tube Label (diameter)	Ar-Hg (10 Torr)			
	Frequency (GHz)	Return Loss (dB)	Gain (dB)	Directivity (dBi)
A (15.9 mm)	3.430	-31.108	2.346	2.381
D (12.7 mm)	3.682	-19.777	2.269	2.296

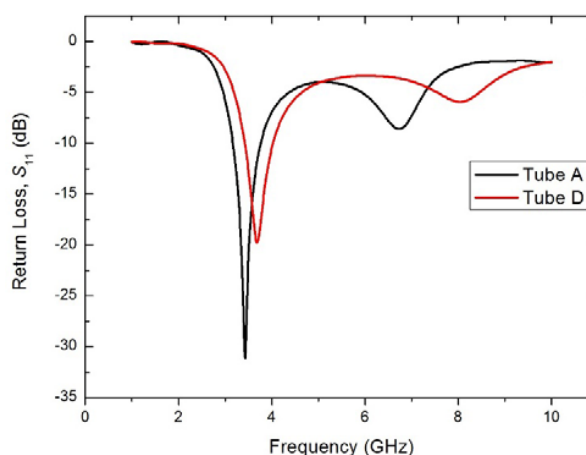

Fig. 4 Return loss for each tube based on different diameter

C. Simulation and Experimental Comparison

Experimental work is focused on return loss and its resonant frequency of plasma antenna. The results of comparison between CST simulation and experiments are shown in Table VII. In terms of return loss, both simulation and experimental results show a good agreement. On the other hand, resonant frequencies shown for both conditions are much different especially for tubes B and C. This might be due to the position of coupling sleeve on the tubes. The coupling sleeve may not be tightened good enough during the experiment that causes an error to the value of return loss. Coupling sleeve is a crucial part in plasma antenna design, and important in order to have good combination between the plasma radiation and external signal.

TABLE VII
RESONANT FREQUENCY AND RETURN LOSS COMPARISON BETWEEN CST
SIMULATION AND EXPERIMENT

Tube Label	Simulation		Experiment	
	Frequency (GHz)	Return Loss (dB)	Frequency (GHz)	Return Loss (dB)
A	3.430	-31.108	4.510	-30.299
B	3.430	-32.570	8.840	-35.104
C	3.430	-32.574	8.956	-29.929
D	3.682	-19.777	5.140	-27.095

V. CONCLUSION

The work had exposed the crucial characteristics of plasma antenna based on the different length and size of fluorescent tube. The results of return loss for simulation and experiment are in the range of -22.863 dB to -32.574 dB. For different lengths of fluorescent tube, the lowest length of tube gives the highest value of return loss. This is because when the shortest length of fluorescent tubes was used, the distance for electron to travel is shorter thus will speed up the electron collision. When the collision frequency is higher, the plasma frequency is also higher thus the increasing in ionization of gas will contribute to the increasing of return loss, gain and directivity value. Meanwhile, for gain and directivity results, it can be concluded that the bigger size of tube diameter has the highest gain and directivity. Some modification is needed in coupling sleeve design in order to reconfirm the resonant frequency experimentally and avoid any error that might be occurred.

ACKNOWLEDGMENT

The authors would like to thank all the laboratory staff in School of Ocean Engineering, Universiti Malaysia Terengganu and Faculty of Electronics and Computer Engineering, Universiti Teknikal Malaysia Melaka for all the support in completing this work.

REFERENCES

- [1] R. Shriwas, S. Gulhane, "Up gradation of Plasma Antenna by Using Fluorescent Tubes", *International Journal of Electronics and Telecommunications*, vol. 3(1), 2015, pp. 9-16.
- [2] I. Alexeff, T. Anderson, S. Parameswaran, E.P. Pradeep, J. Hulloli, P. Hulloli, "Experimental and theoretical results with plasma antennas", *IEEE Transactions on Plasma Science*, vol. 34(2), 2006, pp. 166-172.
- [3] V. Kumar, M. Mishra, N. Joshi, "Study of a Fluorescent Tube as Plasma Antenna", *Progress in Electromagnetics Research Letters*, vol. 24, 2011, pp. 17-26.
- [4] G. Cerri, et al., "Measurement of the Properties of a Plasma Column Used as a Radiating", *IEEE Transactions on Element. Instrumentation and Measurement*, 2008, 57(2), pp. 242-247.
- [5] J. P. Rayner, A. P. Whichello, A. D. Cheerham, "Physical characteristics of plasma antennas", *IEEE Transaction on Plasma Science*, 2004, vol. 32(1), pp. 269-281
- [6] H. M. Zali, M. T. Ali, N. A. Halili, H. Ja'afar, I. Pasya, "Study of Monopole Plasma Antenna Using Fluorescent Tube in Wireless Transmission Experiments", *IEEE International Symposium on Telecommunication Technologies*, 2012, pp. 52-55.
- [7] A. Zhu, Z. Chen, J. Lv, "Reconfigurable Characteristics of the Monopole Plasma Antenna and Its Array Driven by Surface Wave", *WSEAS Transactions on Communication*, 2013, vol 12(4), 2013.
- [8] G. G. Borg, J. H. Harris, "Application of Plasma Columns to Radiofrequency Antennas", *Applied Physics Letters*, vol. 74(22), 1999, pp. 3272-3274.
- [9] L. Wei, Q. Jinghui, S. Ying, "Analysis and Design of Monopole Plasma Antenna", *International Conference on Antenna Theory and Techniques*, 2009, pp. 200-202.
- [10] H. Ja'afar, M.T. Ali, N.A Halili, H.M. Zali, A. N. Dagang, "Analysis and Design between Plasma Antenna and Monopole Antenna", *International Symposium on Telecommunication Technologies (ISTT)*, 2012, pp. 47-51.
- [11] G. G. Lister, S. E. Coe, "GLOMAC: a one dimensional numerical model for steady state low pressure mercury-noble gas discharges", *Computer Physics Communications*, vol. 75(1-2), 1993, pp. 160-184.