

Phase Diagram Including a Negative Pressure Region for a Thermotropic Liquid Crystal in a Metal Berthelot Tube

K. Hiro, T. Wada

Abstract—Thermodynamic properties of liquids under negative pressures are interesting and important in fields of science and technology. Here, phase transitions of a thermotropic liquid crystal are investigated in a range from positive to negative pressures with a metal Berthelot tube using a commercial pressure transducer. Two co-existing lines, namely crystal (Kr) – nematic (N), and isotropic liquid (I) - nematic (N) lines, were drawn in a pressure - temperature plane. The I-N line was drawn to ca. -5 (MPa).

Keywords—Berthelot method, liquid crystal, negative pressure.

I. INTRODUCTION

Thermodynamic properties of liquids under absolute negative pressures are dominated by attractive forces among constituting molecules [1]. Therefore, the properties are interesting and important in fields of science and technology. Unfortunately, there have been fewer reports on negative pressures than those on positive pressures because liquids under negative pressures, which are over-expanded, tend to generate cavities through heterogeneous nucleation [2]. This phenomenon is called cavitation.

One of experiments to generate static negative pressures is the Berthelot method [3]. When a container filled with a liquid including no bubbles is cooled, its pressure decreases and can sustain negative pressures because of differences of isobaric expansion coefficients between the container and the liquid. The containers are made of quartz, glasses, metals, and so on. Metal tubes have three merits, namely high strengths as pressure vessels, mechanical seals without torches, and measurements of pressures by changing densities of liquids, whereas it has been said that they are harder to generate negative pressures than other materials, in particular, glasses [4].

One of authors has purposed to investigate properties of any liquids including polymer solutions under negative pressures. Thus, techniques for metal tubes have been developed to measure properties under negative pressures for any liquids, and negative pressures were attained to ca. -18 (MPa) for water and ca. -20 (MPa) for some organics [5]-[10]. Recently, some properties under negative pressures have been investigated with the techniques.

In this study, a phase diagram for a thermotropic liquid

Kazuki Hiro (corresponding author) and Tadahiyo Wada are with the Department of Mechanical Engineering, National Institute of Technology, Nara College, 22 Yata, Yamatokoriyama, Nara, Japan (e-mail: hiro@mech.nara-k.ac.jp, wada@mech.nara-k.ac.jp).

crystal is drawn with a metal tube made of a commercial pressure transducer. It has been predicted that some thermotropic liquid crystals have tri-critical points under negative pressures [11]. They are also used in liquid crystal displays. Since they are filled in cells, pressures can change with surrounding temperatures. Thus, phase diagrams of thermotropic liquid crystals give useful information on fields of science and technology.

II. EXPERIMENTAL PROCEDURE

A. Metal Berthelot Tube

Fig. 1 shows the Berthelot method with a pressure (P)-temperature (T) graph and a schematic diagram. As shown in (a) of the right figure, when the system composed of a sample liquid sealed in a tube is heated, the pressure of the sample increases because it cannot expand sufficiently for a lower isobaric expansion coefficient of the tube. Next, the system is cooled, and the pressure decreases to (b) of the figure. If cavitation nuclei, namely gases in crevices on the wall of the tube contacting with the sample [10], is pre-reduced, the pressure becomes negative as shown in (c) of the figure. When negative pressure is high, cavitation occurs, and the sample is in vapor-liquid co-existing state. By re-heating the system, the pressure increases gradually to (b) for dissolving a vapor phase to a liquid one and steeply from (b) to (a).

The P - T graph of the left figure shows a relation between pressures and temperatures. Each point in the graph corresponds to that in the right figure. At (c) of the graph, the pressure jumps up to the saturation vapor pressure of the temperature. At a period from (d) to (b), the saturation pressure increases gradually. At (b), a liquid phase starts to occupy the whole inner volume of the tube, and the pressure increases steeply to (a). A process of (abcdba) is called temperature cycle. A temperature of (b) where $P=0$ (0.1 MPa) was called T_0 .

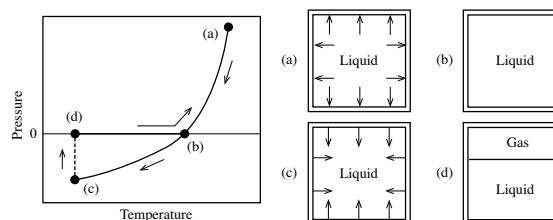

Fig. 1 Berthelot method: P - T graph (left) and liquid in tube (right) [9]

Fig. 2 (a) shows a schematic diagram of the Berthelot tube. The tube consists of a stainless-steel cap, a commercial pressure transducer (Kyowa Elec. Inst. Co., PHL-A) of strain gauges, a commercial brass ball (AKS Co.; 5/16 inch diameter) for sealing a liquid crystal, an o-ring, a nut, and a stainless-steel cup. A top of the transducer was used as a specimen chamber.

The sample was poured into the chamber of ca. 40 (mm³) and was sealed with the ball by compressing it against a sharp edge at the opening of the chamber using the stainless steel thread as shown in Fig. 2 (b). The ball was pre-heated in boiling water and was sometimes pre-exposed to ultrasonic wave in the water or acetone in order to reduce cavitation nuclei on the surface of the ball. The tube was also pre-exposed to the wave.

In this study, the sample was 4-(methoxy phenyl)-trans-4-propyl-cyclohexane-1- carboxylate (Merck Co. D301) as shown in Fig. 3. Reported transition points were Kr57N60.2I at 0.1 (MPa), where each point was expressed in degrees centigrade, and Kr, N, and I denote crystalline, nematic, and isotropic liquid phases respectively. The small difference of ca. 3 (°C) implies that a tri-critical point of I-N transition is hidden in the negative pressure regions which may be experimentally reached [11].

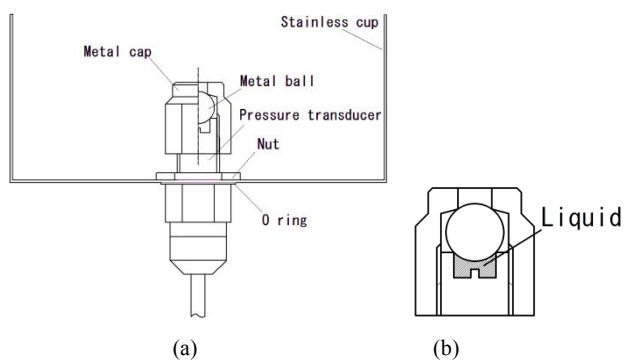

Fig. 2 Metal Berthelot tube

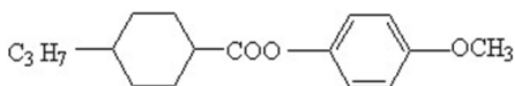

Fig. 3 Thermotropic liquid crystal

The sample liquid crystal, which had been heated so as not to be in Kr phase, was poured into the chamber carefully. The ball was compressed with the metal cap.

The Berthelot system underwent a number of temperature cycles because a repetition of the cycle was indispensable for generation of negative pressures higher than ca. -10 (MPa) [10].

Fig. 4 shows a trend of negative pressures with temperature cycles. Negative pressures increased with temperature cycles. The trend was similar to that reported before [10]. This result indicates that cavitation nuclei in current system were gases in crevices on the wall of the tube contacting with the sample.

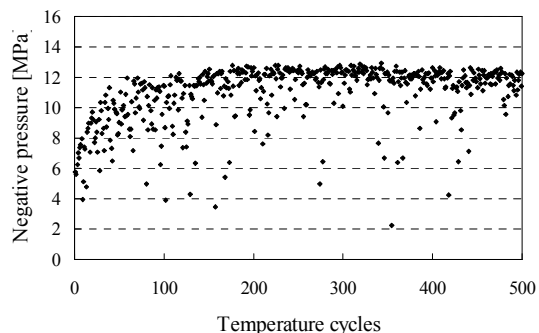

Fig. 4 A trend of negative pressures with temperature cycles

B. Relation between Pressure and Temperature

A pressure-temperature relation of the liquid crystal was measured by immersing the system in a bath which was able to be thermo-controlled with a heater from ca. 30 (°C) to ca. 80 (°C). A platinum resistance thermometer (Sanwa Co., TH3) was located near the system in the bath.

First, the bath temperature was set to a temperature, T_1 . The temperature was higher than T_0 and, therefore, a pressure signal from the transducer in Fig. 2 increased steeply and became almost constant after a while. Then, the pressure and the temperature from the thermometer were measured. The fluctuation of the temperature was within ± 0.1 (°C) and caused that of the pressure signal within ± 0.1 (MPa).

Second, the bath temperature was set to a temperature, T_2 , lower than T_1 . By the same method as T_1 , the pressure and the temperature were measured. Thus, data of pressures and temperatures for a density of the sample liquid crystal in the system were measured until pressures became negative, and a cavitation event occurred at a magnitude of negative pressure.

Next, by compressing the ball further with the metal cap in Fig. 2, another relation at a lower T_0 was drawn. The density of the D301 became higher because the volume of the sample became smaller by the compression.

III. RESULTS AND DISCUSSION

Fig. 5 shows a relation between pressure P and temperature T for a density of the sample in the system. Pressure increases with temperature with two slopes, namely a steep slope from ca. 60 (°C) to ca. 62.5 (°C) shown as a period B, and two other gradual slopes shown as periods of A and C.

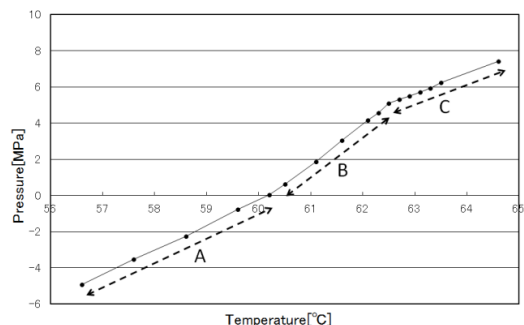

Fig. 5 A P - T relation having different slopes with three periods

The Berthelot system imposes two constraints about two volumes and their changes; the inner volume of the tube V_t and its change dV_t must be equal to those of the sample V_s and dV_s respectively as shown below.

$$V_s = V_t \quad (1)$$

$$dV_s = dV_t \quad (2)$$

The constraints give ratios of pressure increase to temperature one, dP/dTs , corresponding to states of phases in the sample as described below.

At (b) of the right in Fig. 1, V_s is equal to V_t .

$$V_s = V_t = V_b \quad (3)$$

where V_b is the volume of the tube and the sample at (b).

For given changes of temperature dT and, accordingly, pressure dP , volume changes of dV_s and dV_t can be determined as follows:

$$dV_s = \left(\frac{\partial v_s}{\partial T}\right)_P dT + \left(\frac{\partial v_s}{\partial P}\right)_T dP = V_b(\beta_s dT - \kappa_s dP) \quad (4)$$

$$dV_t = \left(\frac{\partial v_t}{\partial T}\right)_P dT + \left(\frac{\partial v_t}{\partial P}\right)_T dP = V_b(\beta_t dT + \kappa_t dP) \quad (5)$$

where β and κ represent the isobaric expansion coefficient and isothermal compressibility, and s and t mean sample and tube. It is important that the latter equation has a positive sign of κ . The reason is that the pressure increase in the system, dP , increases dV_t and decreases dV_s [12].

By substituting (4) and (5) to (2), next equation is obtained.

$$\frac{dP}{dT} = \frac{\beta_s - \beta_t}{\kappa_s + \kappa_t} \quad (5)$$

Now, at (b) in the right of Fig. 1, let's assume that two phases co-exist in the tube like nematic and isotropic liquid phases of a thermotropic liquid crystal. Then, V_s and dV_s are expressed as follows:

$$V_s = Nxv_{1b} + N(1-x)v_{2b} = V_t \quad (6)$$

$$\begin{aligned} dV_s &= Nxdv_{1b} + N(1-x)dv_{2b} + N(v_{1b} - v_{2b})dx \\ &= Nxv_{1b}(\beta_1 dT - \kappa_1 dP) + N(1-x)v_{2b}(\beta_2 dT - \kappa_2 dP) + \\ &\quad N(v_{1b} - v_{2b})dx \end{aligned} \quad (7)$$

where N is the number of moles in the sample, x is a molar fraction of a higher-temperature phase, and v_{1b} and v_{2b} are molar volumes of higher- and lower- temperature phases at (b).

The tube's volume change dV_t is given as shown below.

$$\begin{aligned} dV_t &= V_t(\beta_t dT + \kappa_t dP) \\ &= V_s(\beta_t dT + \kappa_t dP) \\ &= \{Nxv_{1b} + N(1-x)v_{2b}\}(\beta_t dT + \kappa_t dP) \end{aligned} \quad (8)$$

By substituting (7) and (8) to (2) next equation is given [7].

$$\frac{dP}{dT} = \frac{\langle\beta\rangle - \beta_t}{\langle\kappa\rangle + \kappa_t} + \frac{n\delta(v)}{\langle\kappa\rangle + \kappa_t} \frac{dx}{dT} \quad (9)$$

where

$$\langle A \rangle = xv_{1b}A_1 + (1-x)v_{2b}A_2 \quad (10)$$

$$n = \frac{N}{V_s}, \delta(v) = v_{1b} - v_{2b}. \quad (11)$$

Here, brackets $\langle \rangle$ mean volume average of two co-existing phases, and A is β or κ .

Let's note that (9) is equal to (5) in a case that only a single phase exists in the sample because dx/dT is zero for such case.

The second term of (9) implies that the ratio for a co-existing phase is larger than that for a single one. The reason is as follows: when an amount of the sample in N phase in the co-existing state changes the same amount in I phase with an increase in temperature, the volume of I phase is larger than that of N phase because of the larger molar volume. The contribution is expressed as $n\delta(v)$ in the term.

The ratios are sensible to states of phases of the sample; the steep period B in Fig. 5 indicates that the phase is in a co-existing state between N and I phases, while the gradual ones A and C in the figure exhibits single phases, namely N and I phases.

By combining steep slopes of relations obtained for various densities, two co-existing lines, namely I-N and Kr-N lines, were drawn in a P - T plane.

Fig. 6 shows seven P - T relations numbered in order of low densities. The relations 1 and 2 indicated different slopes. The former had only a gradual slope, whereas the latter did a steep one. The relations 3, 4, and 5 had two gradual slopes and one steep slope as shown in Fig. 3. The relation 6 had two steep slopes.

The relation 1 with the gradual slope had a T_0 of ca. 64 ($^{\circ}\text{C}$) higher than an I-N transition temperature of 60.2 ($^{\circ}\text{C}$). So, the sample existed in an isotropic liquid state.

The relation 2 had a steep slope in a negative pressure region; the sample was in a co-existing state in a pressure range from ca. -6 (MPa) to ca. -2 (MPa).

The relations 3 had two gradual slopes and one steep slope. The steep slope crossed at ca. 60 ($^{\circ}\text{C}$) with the axis of $P=0$ (0.1 MPa). The temperature was almost equal to I-N phase transition point, 60.2 ($^{\circ}\text{C}$). So, the relation 3 indicates that the sample was in I-N co-existing state at the steep slope and, at the gradual slopes, in I phase at higher temperatures and pressures and in N phase at lower them.

The relations 4 and 5 for higher densities crossed at ca. 57.5 ($^{\circ}\text{C}$) and ca. 59 ($^{\circ}\text{C}$) with the axis of $P=0$. The temperatures were higher than Kr-N phase transition point of 57 ($^{\circ}\text{C}$), and crossed with the gradual slopes. Thus, in these relations, the sample was in I, I-N, and N phases with decrease in temperature.

The relation 6 for the highest density in Fig. 6 was drawn through a cooling and heating path [7]. The system was cooled until a cavitation event occurred at ca. 50 ($^{\circ}\text{C}$), and the temperature lowered to ca. 47 ($^{\circ}\text{C}$) further because this excess cooling after the cavitation was reported to be effective to crystallize the sample. Next, the system was heated step by step, and data of temperatures and pressures were measured to ca. 30 (MPa).

In the relation 6, there were two steep slopes, namely one from ca. 57 (°C) to 59 (°C), and the other from ca. 70 (°C) to ca. 72 (°C). The former slope crossed at ca. 57 (°C) and $P=0$ where Kr-N phase transition point exists. Therefore, the slope indicates that the sample was in N, N-I, and I with increase in temperature.

Combinations of the steep slopes in Fig. 6 give co-existing lines. The steep slope in the relation 2 was in accordance with that obtained by extrapolating those in the relations 3-6; the slope corresponds to a co-existing line under negative pressures.

Fig. 7 shows two lines calculated with a least square method. The right line is I-N co-existing line, while the left is Kr-N line. The I-N line was drawn to at least ca. -5 (MPa). However, the two lines were not intersected within the magnitude of negative pressure. Higher negative pressures, ca. -40 (MPa), had to be achieved to observe tri-critical point.

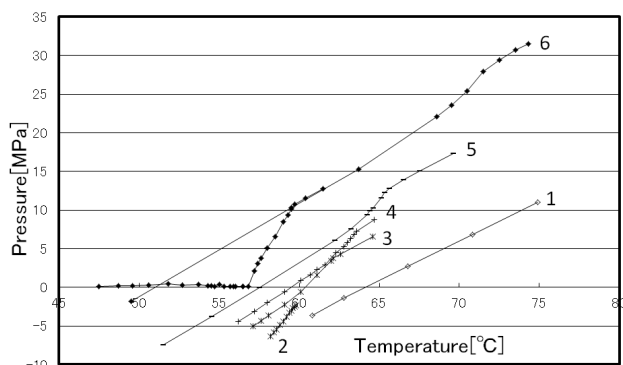

Fig. 6 Six P - T relations numbered in order of low densities

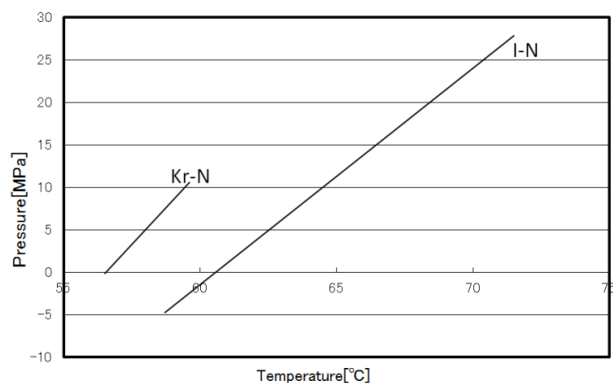

Fig. 7 Two co-existing lines

IV. CONCLUSIONS

A phase diagram including a negative pressure region to ca. -5 (MPa) for a thermotropic liquid crystal, namely 4-(methoxy phenyl)-trans-4-propyl-cyclohexane-1-carboxylate, was depicted with the Berthelot method of a metal tube using a commercial pressure transducer. Two co-existing lines, namely Kr-N and I-N lines, were obtained, but were not intersected within the magnitude of negative pressure. Higher negative

pressures, ca -40 (MPa), had to be achieved to observe tri-critical point. Techniques to generate such magnitude of negative pressures are desirable and seem to be more useful as tools for drawing the diagrams for any liquids including thermotropic liquid crystals.

ACKNOWLEDGMENT

Authors deeply thank Dr. Imre Attila for his encouragement, Messrs K. Onda and K. Shiraishi for their help, and all staff in our department for their support.

REFERENCES

- [1] F. Caupin and A. D. Stroock, "The Stability Limit and Other Open Questions on Water at Negative Pressure (Book style with paper title and editor)," in *Liquid Polymorphism: Advances in Chemical Physics*, 1st ed. vol. 152, H. E. Stanley, Ed. Hoboken: John Wiley & Sons, 2013, pp. 51-80.
- [2] A. R. Imre, H. J. Maris, and P. R. Williams, "Introduction," in *Liquids Under Negative Pressure*, vol. 84, A. R. Imre, H. J. Maris, and P. R. Williams, Eds. Dordrecht: Kluwer Academic Publishers, 2002, pp. ix-xi.
- [3] A. T. J. Hayward, "Negative Pressure in Liquids: Can It Be Harnessed to Serve Man?," *Am. Scient.* vol.59, pp. 434-443, 1971.
- [4] H. N. V. Temperley and L. I. G. Chambers, "The behaviour of water under hydrostatic tension: I," *Proc. Phys. Soc.* vol. 58, pp. 420-436, 1946.
- [5] K. Hiro, Y. Ohde and Y. Tanzawa, "Stagnations of increasing trends in negative pressure with repeated cavitation in water/metal Berthelot tubes as a result of mechanical sealing," *J. Phys. D: Appl. Phys.* vol.36, pp. 592-597, 2003.
- [6] Y. Ohde, H. Watanabe, K. Hiro, K. Motoshita and Y. Tanzawa, "Raising of negative pressure to around -200 bar for some organic liquids in a metal Berthelot tube," *J. Phys. D: Appl. Phys.* 26, pp. 1088-1191, 1993.
- [7] Y. Ohde, Y. Tanzawa, K. Motoshita and K. Hiro, "Thermobarometry for 4'-n-Octylbiphenyl-4-carbonitrile in Metal Tube Berthelot Method and Polymorphism in Crystalline Phase of 4'-n-Octylbiphenyl-4-carbonitrile Found through Cooling Paths in Negative -Pressure Range," *Jpn. J. Appl. Phys.* vol. 47, pp. 5591-5601, 2008.
- [8] K. Hiro, T. Wada, and K. Kumagai, "Temperatures of maximum density in a pressure range from 15 MPa to -15 MPa generated for water in a metal Berthelot tube," *Physics and Chemistry of Liquids*, vol.52, pp. 37-45, 2014.
- [9] K. Hiro, T. Wada, "Phase Diagram of Thermotropic Liquid Crystal Including Negative Pressure Region Generated in Metal Berthelot Tube," *Solid State Phenomena*, vols. 181-182, pp. 22-25, 2012.
- [10] Y. Ohde, M. Ikemizu, H. Okamoto, W. Hosokawa, and T. Ando, "The two-stage increase in negative pressure with repeated cavitation for water in a metal Berthelot tube," *J. Phys. D: Appl. Phys.*, vol. 21, pp. 1540, 1998.
- [11] S. J. Rzoska, and A. D. Rzoska, "On the Tricritical Point of the Isotropic - Nematic Transition in a Rod-Like Mesogen Hidden in the Negative Pressure Region," in *Liquids Under Negative Pressure*, vol. 84, A. R. Imre, H. J. Maris, and P. R. Williams, Eds. Dordrecht: Kluwer Academic Publishers, 2002, pp. 117-125.
- [12] B. E. Richard, and D. H. Trevena, "The measurement of positive and negative pressures in a liquid contained in a Berthelot tube," *J. Phys. D: Appl. Phys.*, vol. 9, pp. 123, 1976.