

Performance Evaluation of Single-mode and Multimode Fiber in LAN Environment

Farah Diyana Abdul Rahman, Wajdi Al-Khateeb, and Aisha Hassan Abdalla Hashim

Abstract—Optical networks are high capacity networks that meet the rapidly growing demand for bandwidth in the terrestrial telecommunications industry. This paper studies and evaluates single-mode and multimode fiber transmission by varying the distance. It focuses on their performance in LAN environment. This is achieved by observing the pulse spreading and attenuation in optical spectrum and eye-diagram that are obtained using OptSim simulator. The behaviors of two modes with different distance of data transmission are studied, evaluated and compared.

Keywords—Attenuation, eye diagram, fiber transmissions, multimode fiber, pulse dispersion, OSNR, single-mode fiber.

I. INTRODUCTION

THE goal of an optical fiber communication system is to transmit the maximum number of bits per second over the maximum possible distance with the fewest errors [1]. Since fiber transmission is a dispersive medium, implying that pulses spread as they travel through the fiber, some form of dispersion compensation is applied at each repeater stage. There is a limit to the highest frequency, i.e. how many pulses per second, which can be sent into a fiber and be expected to emerge intact at the other end. This is because of a phenomenon known as pulse spreading which limits the "Bandwidth" of the fiber.

Multimode fiber has a larger core diameter and it carries the signal strength in a variety of ways. This results in dispersion of the signal or spreading of the optical pulse in time. This limits the data rate or bandwidth. Single-mode fiber, in contrast, has a core diameter (less than 10 μm), which is small enough to prevent "multipath" effect. Single-mode fiber is the type used in long haul telecommunications. Table 1 provides comparisons between multimode fiber and single-mode fiber [2].

This paper is organized as follows. Section 2 points out some of the related researches in fiber optic. The simulation scenarios are mentioned in section 3. Section 4 presents the results and discussion, followed by the conclusion in section 5.

Authors are with Department of Electrical and Computer Engineering, Faculty of Engineering, International Islamic University Malaysia, Jalan Gombak, 53100, Kuala Lumpur, Malaysia (e-mail: diyanarmi@yahoo.com, wajdi@iiu.edu.my, aisha@iiu.edu.my).

TABLE I
GENERAL SPECIFICATIONS OF FIBER

Waveguide Conductor	Bandwidth-Distance Product (MHz-Km)	Attenuation (Db/Km)
Multimode Fiber	>400	2.0
Single-Mode Fiber	>25000	1.0 (Typically < 0.5)

II. RELATED WORKS

There are several works focusing on analyzing fiber performance by exploiting different aspects of fiber. Work in paper [1] focuses on the modulation scheme for long-haul systems, i.e., the format used to create the optical pulses. Such approach, however, has given more attention to the modulation format. While research paper in [3] and [4] focus more on limitation to WDM transmission distance due to cross-phase modulation induced spectral broadening in dispersion compensated standard fiber systems and also on optimization of WDM transmission of multi-10 Gbit/s, 50 GHz-spaced channels over standard fiber. A work in [5] studies FIR filter pre-emphasis for high-speed backplane data transmission. However, the work does not include research on the transmission modes.

III. SIMULATIONS

A. OptSim Simulator

An all-optical network simulator is used for the performance analysis of fiber in LAN environment. The simulator is OptSim 4 from RSoft Design Group. This software is an intuitive modeling and simulation environment supporting the design and the performance evaluation of the transmission level of optical communication systems. It provides suitable platform for automated design of all optical networks. OptSim features many attributes and the simulation is based on its performance analysis monitors (e.g. Q value, BER, Power spectra and OSNR, eye diagram). It also provides a wide and complete choice of measurement (e.g. jitter, eye opening/closure, electrical/optical spectra, chirp, optical instantaneous phase/frequency and power).

B. Simulation Scenarios

This paper applies two different scenarios; one for single-mode fiber and the other is for multimode fiber. For each case,

simulation is done using different length of the fiber, i.e., the distance of data transmission. The block diagrams for single-mode and multimode fiber are shown in Fig.1 and Fig.2.

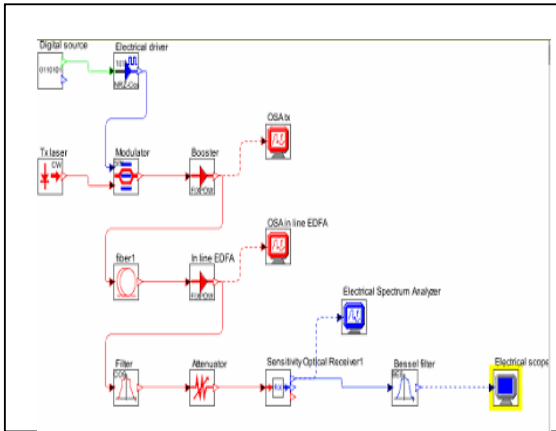

Fig. 1 Block diagram for single-mode fiber

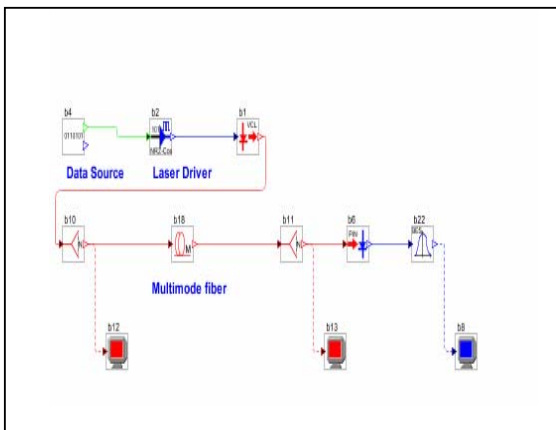

Fig. 2 Block diagram for multimode fiber

The block diagrams depicted typical digital fiber optic links. Electrical data signals converted to optical signals via a modulator. It is then boosted by an optical amplifier before launched into an optical fiber. The signals are amplified by an optical Erbium doped fiber amplifier (EDFA) after each span. At the receiving end, a sensitivity optical receiver (Fig.1) and a photodiode (Fig.2) detect the optical signal and convert it back to electrical signal. Filter is used to filter out all the amplifier noise. The optical spectrum of the transmission is collected at the Optical Spectrum Analyzer (OSA), which is the red monitor icon. This analyzer is situated before and after the fiber medium as to see its performance after certain distance. This is where the range of the fiber lengths plays an important role. The optical spectrum under OSA in line with EDFA and the eye diagram at the received electrical scope are analyzed. Both results are taken after data transmission has fully passed the fiber that is under examination. In order to analyze pulse spreading and attenuation, optical spectrum before and after data transmitted has to be studied.

IV. RESULTS AND ANALYSIS

Simulation is carried out for both single-mode and multimode fiber with different data transmission distance. The main objective is first to study the pulse spreading, and second to study the attenuation of the modes with respect to different transmission distance. Fig.3 shows the optical spectrum before transmission while Fig.4 shows the optical spectrum after transmission.

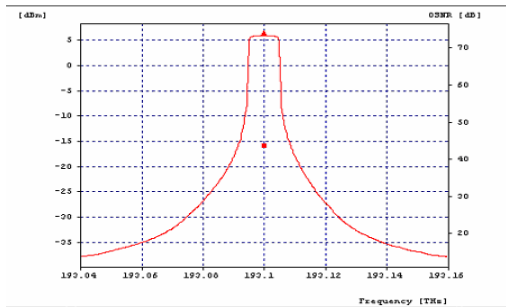

Fig. 3 Optical spectrum before transmission

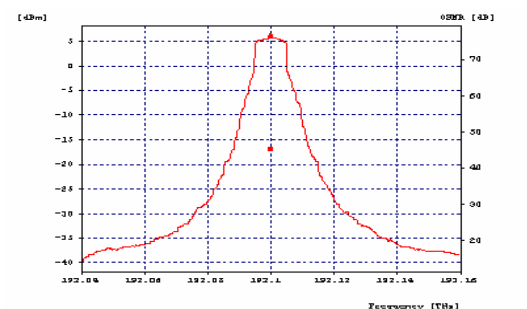

Fig. 4 Optical spectrum after transmission

Comparing the two graphs in Fig.3 and Fig.4, it can be clearly seen that the value of OSNR has been reduced from 46dBm to 44dBm. This proves that the pulse is spreading. It can also be noticed that the spectrum from before entering fiber transmission is smoother compared to the one received after transmitting along the fiber.

The figures below show the eye diagram plots with different transmission distance, Fig.5 shows eye diagram plots for multimode at 10Gb/s after transmission of 50m, Fig.6 after 100m and Fig.7 after 200m. In this simulation, the reference number is chosen to be 10^{-12} . It is observed that the attenuation increases as the distance increases. This can be seen through the eye opening, which created by signals superimposed. The eye opening of the plots indicates the region which is lower than the reference number.

This means that the region represents signal that has bit error rate less than 10^{-12} . The larger the eye opening implies less attenuation of eye-opening, hence better transmission. Fig.5 shows a very wide eye-opening, thus less error occurred during transmission. Fig.6 shows less wide eye-opening, which indicates more error occurred compared to Fig.5. Fig.7 shows that the region of eye-opening is closing, smaller and reduced. Hence, it is observed that as the distance of transmission increased, greater channel loss is obtained and

due to absorption, scattering and bending, that cause the eye opening to be reduced.

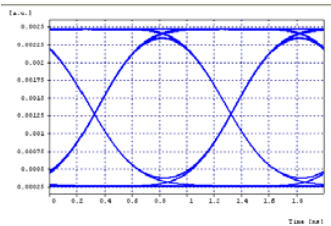

Fig. 5 Eye diagrams after 50m

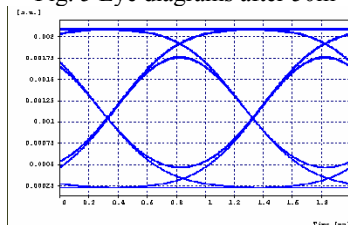

Fig. 6 Eye diagrams after 100m

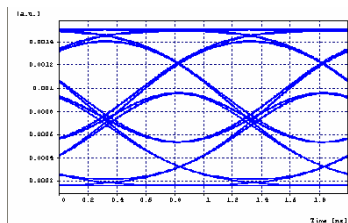

Fig. 7 Eye diagrams after 200m

The figures below show the eye diagram plots with different transmission distance, Fig.8 shows eye diagram for single-mode at 10Gb/s after transmission of 50m, Fig.9 after 100m and Fig.10 after 40km. In this simulation, the reference number is also chosen to be 10^{-12} . It is observed that the attenuation decreases as the distance increases. This can be seen through the eye opening, which created by signals superimposed. The eye opening of the plots indicates the region which is lower than the reference number.

This means that the region represents signal that has bit error rate less than 10^{-12} . The larger the eye opening implies less attenuation of eye-opening, hence better transmission. Fig.8 shows that the region of eye-opening is closing, smaller and overlapped. Fig.9 shows a wider eye-opening, thus less error occurred during transmission. Fig.10 shows even wider eye-opening, which indicates less error occurred compared to Fig.8. Hence, for single-mode fiber, the attenuation reduces for increasing distance of transmission. For multimode fiber, the attenuation increases when the distance of transmission increases.

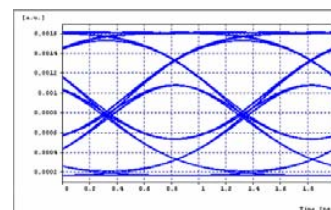

Fig. 8 Eye diagrams after 50m

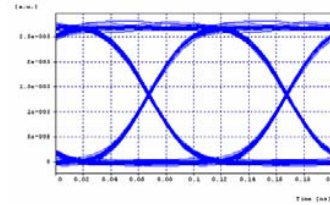

Fig. 9 Eye diagrams after 100m

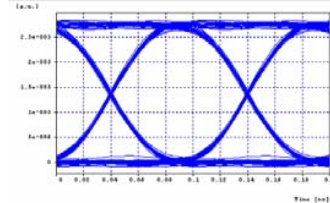

Fig. 10 Eye diagrams after 40km

V. CONCLUSIONS

This paper presents a comparative study of single-mode and multimode fiber in LAN environment. Simulation is done using OptSim and it is an intuitive modeling and simulation environment supporting the design and the performance evaluation of the transmission level of optical communication systems. Graphs of optical spectrum (before and after transmission) show that pulse spreading occurs as the signal propagate down the optical fiber. Single-mode and multimode fiber were compared as the distance varied using eye-diagrams. The eye-opening is larger when less attenuation occurs. As for single-mode fiber, the eye-opening is larger as the distance increases but over certain range only. However for multimode fiber, the eye-opening is large at short distance only. It was shown through the simulation that single-mode fiber performs better than multimode fiber in long-haul transmission, in terms of attenuation. In short distance transmission, however, multimode fiber is much suitable if compared to single-mode fiber. This is due to pulse spreading and dispersions within the fiber.

REFERENCES

- [1] Anjali Singh, "Modulation Formats for High-Speed, Long-Haul Fiber Optic Communication Systems." Inphi Corporation.
- [2] Fiber Optics Rotary Joints. Available: <http://www.focaltech.ns.ca/html>
- [3] V. Mikhailov et al, "Limitation to WDM Transmission Distance due to Cross-Phase Modulation Induced Spectral Broadening in Dispersion Compensated Standard Fiber Systems." IEEE.
- [4] R. I. Killey et al, "Optimisation of WDM Transmission of Multi-10 Gbit/s, 50 GHz-Spaced Channels over Standard Fiber." IEEE.
- [5] OptSim Models Reference.
- [6] P.M.Watts et al, London Communications Symposium (2003), p69
- [7] H.Bülow et al, OFC 2001, WDD34-1
- [8] P. Kirkpatrick et al, T. Mader, S. Shang, C. Schulz, D. Sprock and J-M Verdiell, 2004, "10 Gb/s Optical transceivers: fundamentals and emerging technologies." Intel Technology Journal, Volume 8, Issue 02.
- [9] F. Devaux et al, 1993, "Simple measurement of fiber dispersion chirp parameter of intensity modulated light emitter." Journal of Lightwave Technology, Volume 11, No. 12.
- [10] D.M. Rothnie et al, 1996, "Improved standard fiber performance by positioning the dispersion compensating fiber." Electronics Letters, Volume 32.
- [11] M.Sieben et al, J. of Lightwave Tech., Vol.17 (1999), p1742.