

Performance Enhancement of Analog Voltage Inverter with Adaptive Gain Control for Capacitive Load

Sun-Ki Hong, Yong-Ho Cho, Ki-Seok Kim, Tae-Sam Kang

Abstract—Piezoelectric actuator is treated as RC load when it is modeled electrically. For some piezoelectric actuator applications, arbitrary voltage is required to actuate. Especially for unidirectional arbitrary voltage driving like as sine wave, some special inverter with circuit that can charge and discharge the capacitive energy can be used. In this case, the difference between power supply level and the object voltage level for RC load is varied. Because the control gain is constant, the controlled output is not uniform according to the voltage difference. In this paper, for charge and discharge circuit for unidirectional arbitrary voltage driving for piezoelectric actuator, the controller gain is controlled according to the voltage difference. With the proposed simple idea, the load voltage can have controlled smoothly although the voltage difference is varied. The appropriateness is proved from the simulation of the proposed circuit.

Keywords—Analog voltage inverter, Capacitive load, Gain control, DC-DC converter, Piezoelectric, Voltage waveform.

I. INTRODUCTION

PIEZOELECTRIC is widely used in various areas as smart oil-pressure pump, smart valve, ultrasonic motor etc. They are operated by special inverter because they acts as R-C loads. Some piezoelectric actuators are operated using H-bridge inverters which can apply positive or negative voltages to the R-C or piezoelectric loads [1], [2]. Some loads made of single crystal need unidirectional voltage when the applied voltage is very high. For piezoelectric pump, square-wave unidirectional voltage is applied to the load [3]-[5]. For piezoelectric valve, the applied voltage needs to be controlled arbitrarily. In the previous study [1], a special inverter was developed. Once the load is charged, the energy charged in the load doesn't discharged by itself and discharging circuit is added. However the difference between power supply voltage level and the load voltage level for RC load is varied. Because the control gain is constant, when the voltage difference is large, the controlled output is varied abruptly, and when small, the output voltage cannot follow well the reference voltage. In this paper, for charge and discharge circuit for unidirectional arbitrary voltage driving for piezoelectric actuator, the controller gain is controlled according to the voltage difference. With the proposed simple algorithm, the load voltage can have controlled smoothly although the voltage difference is varied.

Sun-Ki Hong is with the Dept. of Digital Control Eng., Hoseo University, Asan, Chungnam, 336-795, Korea (phone: +82-41-540-5674; e-mail: sunkih4@naver.com). corresponding author

Young-Ho Cho and Ki-Seok Kim are now on M.S course with the Department of Information Control, Asan, Chungnam, 336-795, Korea (e-mail: kingka0324@naver.com, park108a@naver.com).

T.S. Kang is with the Dept. of Aerospace Information Eng., Konkuk University, Seoul Korea (e-mail: ts kang@konkuk.ac.kr).

The simulation and experiment results are compared to verify the proposed model.

II. UNIDIRECTIONAL ANALOG INVERTER

Fig. 1 shows the analog voltage output inverter [5]. In this circuit, S_1 is charging switch and S_2 is discharging switch. R_L and C_L are R-C load. R_b is voltage feedback resistor to detect the output voltage.

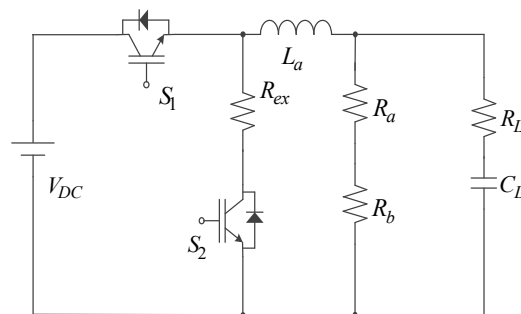


Fig. 1 Proposed analog voltage output inverter

When charging, switch S_1 is on and S_2 is off. The load current flows from the voltage source to the R-C load through L_a . When discharging, the switch S_1 turns off and S_2 is turned on. If the increasing rate of the voltage needs to be controlled, the duty of the switch S_1 should be adjusted. If the load voltage needs to be decreased, S_1 becomes to turn off and S_2 begins to act. If S_2 is turned on, the charged energy in the load is discharged through the discharging resistor R_{ex} . The load voltage is measured by the feedback resistor.

Fig. 2 shows the control scheme for the above converter. The reference is compared with the feedback voltage. The error is controlled with PI controller. This controller determines the duty and which switch is turned-on or off.

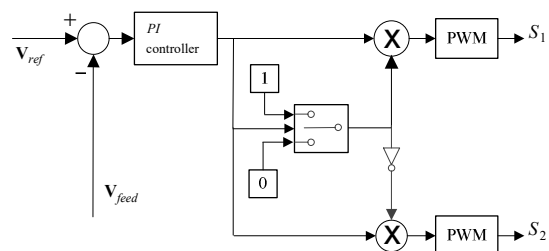
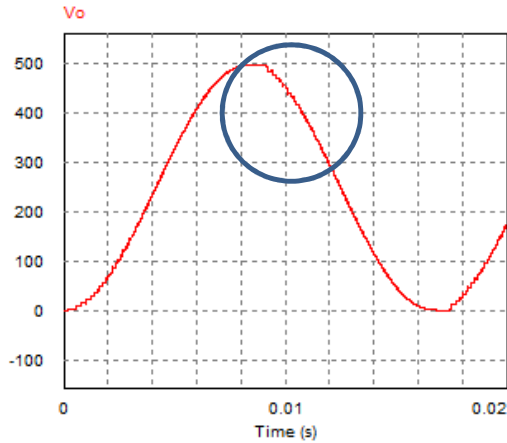


Fig. 2 Control scheme for unidirectional analog inverter

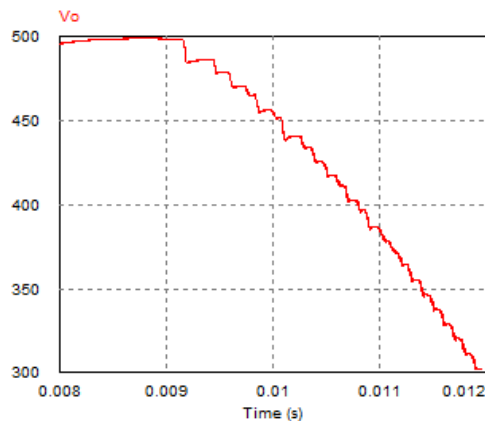
III. POSSIBLE PROBLEM

A. Output Voltage Waveform

Fig. 2 shows the output voltage waveform with the unidirectional analog voltage inverter with simulation tool. The reference frequency is 60 [Hz] sinusoidal waveform. Fig. 2 (a) shows the full waveform and Fig. 2 (b) shows the magnified waveform of the circle in Fig. 2 (a).



(a) Output voltage waveform



(b) Magnified voltage waveform of (a)

Fig. 2 Output voltage waveform of analog inverter

As one can see in the figure, the waveform looks like sinusoidal. However, if the waveform is magnified, the waveform is not smooth because the waveform is generated by switching. Especially when the voltage begins to increase from the bottom or when the voltage begins to decrease from the top, the waveform undulation is not ignorable. The reason is explained next section. These phenomenon becomes more serious if the reference frequency is increased. It can be explained that the gradient of the output voltage is also increased which means the increment or decrement grow at the same time step because the reference frequency is increased. If the voltage waveform is important or not ignorable, this

problem needs to be solved and this can be solved with software algorithm.

B. Analysis of Undulation of Voltage Waveform

Fig. 3 shows the reason the waveform is not smooth at top or bottom area. When the reference voltage is increasing, the charging switch S_1 is on and the current flows from the power supply to the piezoelectric load. At the beginning, the voltage difference between the power source and the load is maximum. Therefore maximum current may flow at the one time step which makes the output voltage increased abruptly because this inverter is controlled by digital PI controller. To remove this undesirable waveform, the PI gains can be adjusted or decreased then the output waveform at the top would be distorted. On the contrary, when the reference voltage begins to decrease, the discharging switch S_2 is on and the current flows from the load to ground through discharging resistor R_{ex} . In this moment, the voltage difference is also maximum because the output voltage is maximum and the voltage difference is same with the output voltage. By the same way, the current tries to flow abruptly and the voltage drop is also big at this time step and the result is shown in Fig. 2.

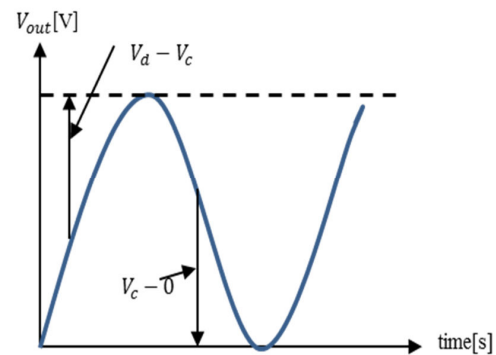


Fig. 3 Voltage difference according to output voltage

IV. PROPOSED ALGORITHM

As explained at the previous section, some technical solution is required if high quality output voltage waveform is desired. This is for applying arbitrary voltage to piezoelectric load by a special inverter. The difference between the power source voltage and output voltage is considered to apply analog voltage to the piezoelectric load. As a result, the output voltage follows well the reference voltage from low voltage to high voltage.

Piezoelectric material has very short mechanical time constant and cannot be operated with conventional PWM method. High capacitive power amplifier is very expensive and large volume although it may have high performance. Therefore a special inverter is required and developed [1]. To remove the error, PI method is usually used. If the voltage difference is large, the compensating output varies much although with same magnitude of error. The object of this study is minimizing the power source capacity including high quality voltage waveform. Fig. 4 shows the proposed scheme block. The dotted box shows the control scheme which includes gain

control block. Fig. 4 also includes the inverter block in Fig. 1. At first, the error between the reference and the real output voltage is detected. With this value, the control output is determined to make the error to be 0. The control output is compensated at the gain control block according to the nonlinearity from the difference between the driving voltage V_{cc} and the output voltage V_C . The PWM signals proportioned to the compensated output signal are applied to the charging and discharging switches S_1 and S_2 . With this algorithm, the error between output voltage and reference voltage becomes 0.

Fig. 5 shows the charging stage circuit and the switch S_1 is controlled by PWM signal.

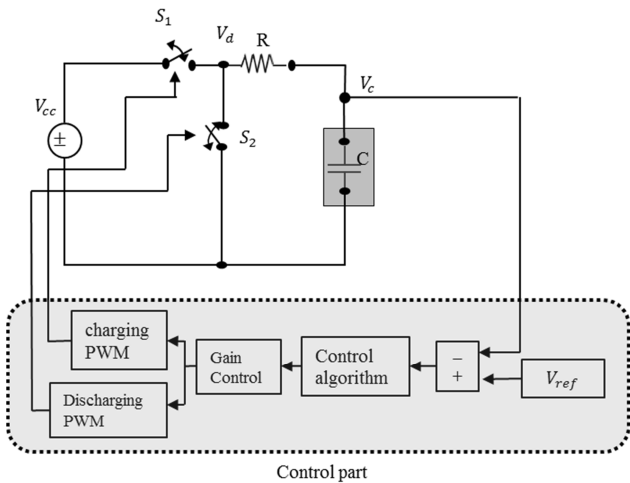


Fig. 4 The proposed total system block

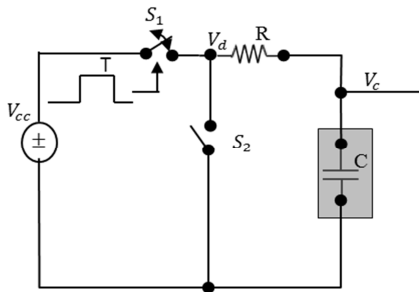


Fig. 5 Charging stage circuit

If the switch on time is small enough compared to the constant of resistor R and capacitor C , the following equation is satisfied.

$$\Delta V = V_c(T) - V_c(0) \approx (V_{cc} - V_c(0)) \frac{T}{RC} \quad (1)$$

As can be seen in (1), the variance of the output voltage is proportioned to not only the on time T but the voltage difference of $V_{cc} - V_c(0)$. To operate the controller linearly, this nonlinearity should be compensated.

The compensation is executed in the ‘Gain Control’ block in Fig. 4. From (1), the nonlinear component is the voltage difference, therefore the reciprocal or its approximation value of the voltage difference needs to be multiplied to the control output. The compensation gain becomes (2).

$$K_{adj}(t_k) = \frac{1}{|V_{cc} - V_c(0)|} \quad (2)$$

In (2), t_k is k -th time step. In the case of discharging stage, only the source voltage is changed to ground 0. That is to say, if the control output is positive, the discharging switch S_2 is open and the charging switch S_1 is controlled by the charging PWM signal. On the contrary, if the control output is negative, the charging switch S_1 is open, S_2 is controlled by the discharging PWM signal, which is explained in Fig. 6. With this method, the increment or decrement of the output voltage becomes constant and the shape of the output voltage becomes smooth.

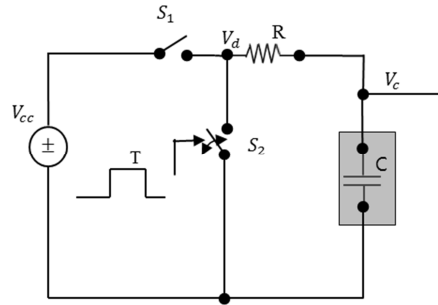


Fig. 6 Discharging stage circuit.

Fig. 7 shows the gain pattern when (2) is used. The 2 gain functions are continuous but the gain needs to be changed at the moment the sign of the gradient of the output voltage is changed. At the peak point of the output voltage, charging gain is maximum and discharging gain is minimum. On the contrary, when the output voltage is minimum, the charging gain is minimum and discharging gain is minimum. The result is simulated and experimented at the following section.

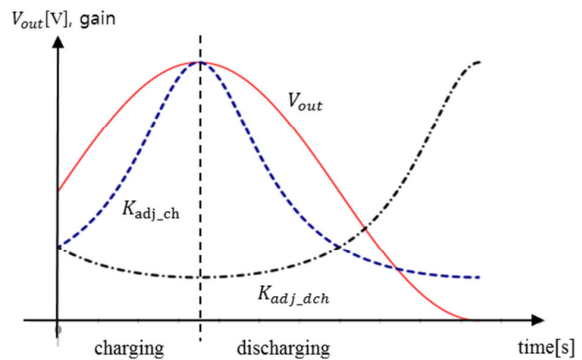
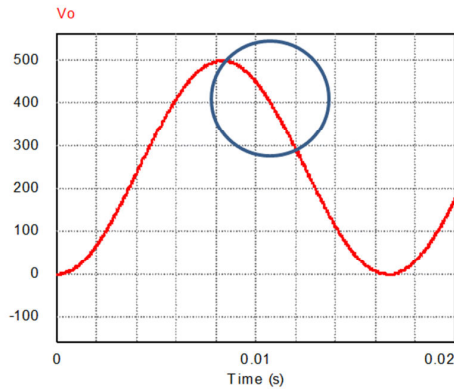


Fig. 7 Compensation gain for output voltage.

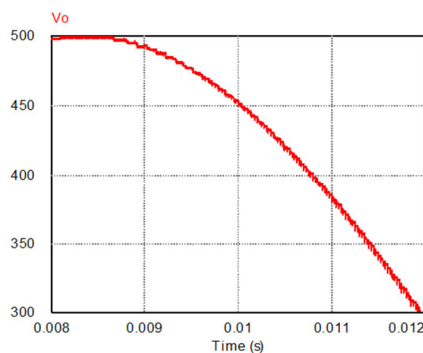
V. SIMULATION AND EXPERIMENT RESULT

A. Simulation Result.

Fig. 8 shows the output voltage waveform with the unidirectional analog inverter controlled by the proposed algorithm. The operating condition is same with the case of Fig. 2. Fig. 8 (a) shows the full voltage waveform and Fig. 8 (b) shows the magnified waveform of the circle in Fig. 8 (a).



(a) Output voltage waveform



(b) Magnified voltage waveform of (a)

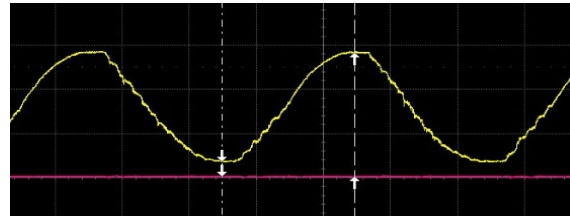
Fig. 8 Output voltage waveform of analog inverter

By comparison of Fig. 8 (b) with Fig. 2 (b), it is trivial that the smoothness of the output voltage is much improved. Fig. 9 shows the assembled converter-inverter system. The max output voltage is 500 [V].

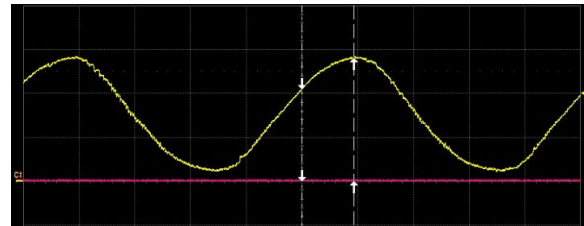


Fig. 9 Compensation gain for output voltage

B. Experimental Result



(a) Output voltage waveform without proposed algorithm



(b) Output voltage waveform with proposed algorithm

Fig. 10 Experimental output voltage waveform

Fig. 10 (a) shows the voltage waveform with the device in Fig. 9 without the proposed algorithm and Fig. 10 (b) is the output waveform by the proposed method. It is clear that the gain control affects the output voltage waveform so much.

VI. CONCLUSIONS

For unidirectional arbitrary voltage driver, a special inverter with circuit that can charge and discharge the capacitive energy is used when the load is capacitive. In this case, the waveform of the output voltage is not smooth if the reference voltage varies a lot when the control gain is constant. In this paper, according to the state of charge and discharge, the controller gain is controlled considering the voltage difference between power source and load voltage. With the proposed simple idea, the load voltage can have controlled smoothly although the voltage difference is varied. Through the simulation and experiments, it is conformed the proposed method is appropriate to get smooth voltage waveform for piezoelectric load.

REFERENCES

- [1] S. Hong, N. Byun, J. Lee, T. Kang, "A Study on Unidirectional Analog Output Voltage Inverter for Capacitive Load", WASET, Vol. 8, pp490 - 493, 2014-07.
- [2] S.C.Lee, S.Y.Soh, J.W.Seo and B.K.Kang, "Versatile energy recovery circuit for driving AC plasma display panel with single sustain circuit board", Displays, Volume 27, Issues 4-5, pp.153-160, Nov. 2006.
- [3] F. S. Kang, S. J. Park, J. H. Cho, W. S. Yoon, C. U. Kim, High-Performance Sustain Driver for Plasma Display," IEEE Trans. Ind. Electron., Vol. 53, No. 4, pp. 1322-1327, Aug., 2006.
- [4] Sun-Ki Hong, Jung-Seop Lee, Nam-HeeByeon, Tae-Sam Kang, Jeong Hoi Gu, "Energy Recovery Circuit and Asymmetric Voltage Driving Circuit for Piezoelectric Elements," The 7th World Congress on Biomimetics, Artificial Muscles and Nano-Bio (BAMN2013), August 26-30,2013, Jeju Island, South Korea.
- [5] Sun-Ki Hong, Jung-Seop Lee, Nam-HeeByeon, Taesam Kang, "A Study of Unidirectional Driving Circuit of Piezoelectric Device Considering Energy Recovery," Applied Mechanics and Materials, Vol. 490-491, pp.1053-1056, 2014.