

# Patents Analysis and Design Suggestions for the Mandibular Advancement Devices

Tsung-yin Lin and Yi-yu Lee

**Abstract**—Snoring is prevalent and is the most significant feature of sleep-disordered breathing (SDB). Ignore the therapies of SDB will lead to serious problems in health. Based on the research of mechanisms, diagnosis, and treatments of snoring, oral appliances are ensured in therapeutic effect and compliance, especially the mandibular advancement devices (MADs). Market survey includes commercial product reviews and patent analyses. Due to pay more attention to the sleep medicine, the oral appliances are considered as a standard treatment of snoring that promoted by American Academy of Sleep Medicine (AASM). There are more and more adjustable MADs developed since 1995. According to the patent analyses, there are many drawbacks existed in the present design, such as uncomfortable, high cost, bulky volume, and complex adjustment. In this study, several new designs of the MAD are proposed.

**Keywords**—mandibular advancement device, mechanism design, patent review

## I. INTRODUCTION

RESPIRATION plays the key role of human life which removes gas in and out from the lungs. Oxygen and carbon dioxide can be exchanged between air and blood to supply the needs of all activities in human body. The passageways between the ambient environment and the gas-exchange unit, the alveoli, in the lungs are called the conducting airways. The conducting airways are divided into the upper airways and the lower airways [1], [2]. If there is some resistance occurred in these airways to reduce the quantity of inspiration into the lungs when the time of sleeping, it might be the symptom of sleep-disordered breathing.

The upper airways are composed of the nose, oral cavity, pharynx, and larynx. The larynx represents the transition between upper and lower airways. The primary functions of the upper airways are to humidify and warm the inspired air, and to filter out and prevent foreign materials from entering the tracheobronchial tree. The maxilla forms the anterior portion of the nasal cavity floor, called the hard palate. The posterior portion of nasal cavity floor is the muscular soft palate [3]. After the inspired gas passes through the nasal cavity, it enters the pharynx. The pharynx is divided into three parts which are the nasopharynx, oropharynx, and laryngopharynx. The nasopharynx is located on the posterior portion of the nasal cavity and superior to the level of soft palate.

Tsung-yin Lin is with the Mechatronic, Energy and Aerospace Engineering Department, National Defense University in Taiwan. (phone: 886-988-211181; fax: 886-3-3907306; e-mail: tsylin0912@hotmail.com).

Yi-yu Lee is with Delta Electronics, Inc., Taiwan.

Next to the nasopharynx, the oropharynx lies between the soft palate superiorly and the base of the tongue inferiorly. The laryngopharynx, also called the hypopharynx, is the space below the oropharynx and above the entrance of the esophagus.

The resistance of the airflow through the nose is greater than that through the mouth. The reason is that the structures in the nose are designed to accomplish the filtering, warming, and humidifying functions. The raising resistance sometimes causes people to switch to mouth breathing. Therefore, the oral cavity is considered as an accessory respiratory passageway to ensure the quantity of sufficient inspiration for needs. As the sleep-disordered breathing (SDB) occurred, it may possibly affect the patient's sleep quality possibly. The patient's sleep fragment will cause awakening or partial awakening, or disrupt the patient's sleep. It makes the patient feel restless and sleepiness in the daytime. SDB is a term including several different states of breathing disorder. In accordance with the degrees of the severity, from mild to severe, it can be classified progressively as follows [4]:

- 1) Primary snoring disorder (PSD): snoring without sleep disruption and without excessive daytime sleepiness (EDS).
- 2) Upper airway resistance syndrome (UARS): usually accompanied by snoring. Besides, increasing respiratory effort against airway resistance may lead to sleep fragmentation and cause excessive daytime sleepiness.
- 3) Obstructive sleep hypopnea syndrome (OSHS): snoring with partial airway obstruction, but not complete apneas, associated with excessive daytime sleepiness and other symptoms of OSAHS.
- 4) Obstructive sleep apnea-hypopnea syndrome (OSAHS): snoring with documented hypopneas and apneas, associated with excessive daytime sleepiness and other symptoms of OSAHS.
- 5) Obstructive sleep apnea syndrome (OSAS): snoring with documented apneas, associated with excessive daytime sleepiness and other symptoms of OSAHS, practically synonymous with OSAHS.
- 6) Mixed sleep apnea syndrome (MSAS): combination of central sleep apnea (CSA) and obstructive sleep apnea (OSA), associated with symptoms of OSAHS.

Therefore, snoring can be seen as an obvious representation of the sleep-disordered breathing during human sleep.

Although, lots of therapies in treating snoring and OSA have been proposed already, they still have some problems, such as the efficacy and safety of therapies, the compliance and

complications after treated, the failure of the device, the breakdown of the mechanism. Those shortages mentioned above are required to be solved.

## II. NON-SURGICAL TREATMENTS OF OSA

Various treatments of snoring and OSA can be generally classified into surgical treatments and non-surgical treatments. Standard treatments for OSA which have been proven by American Academy of Sleep Medicine (AASM) including upper airway surgery and the use of positive airway pressure appliance and oral appliance [5] - [8].

The application of the oral appliance for the treatment of obstructive sleep apnea was first introduced in 1984 [9]. Various oral appliances have been developed for the treatment of snoring and/or OSA. With different designs, they can be classified into three basic categories as follows:

- 1) Mandibular advancement devices (MADs): it also termed as the Mandibular reposition devices (MRDs). These are removable devices which are worn at night during sleep. Most devices require dental impression, bite registration, and fabrication by a dental laboratory. Those devices are fixed to upper and lower teeth and are adjusted to advance the mandible. The amount of protrusion is adjusted to meet the therapeutic requirements, comfort, and tolerance. Many devices have a fixed degree of advancement. Some are adjustable in a limited degree.
- 2) Tongue-retaining device (TRD): it is designed to keep the tongue in an anterior position during sleep. The tongue is held in place by a negative pressure in a soft plastic bulb, which protrudes out of the mouth. The lips are closed over a flange which fits between the lips and teeth to hold the device.
- 3) Soft palate lift (SPL): these removable devices are also for nighttime use during sleep. A posterior extension is fitted up upper teeth to lift the soft palate and uvula out of the pharyngeal airway. These devices have not demonstrated efficacy in reducing either snoring or OSA.

All oral appliances produce downward rotation of the mandible, many of them also move forward the mandible by design. In a comparative study, a strong patient preference appeared for the MAD. The MAD was an effective treatment and the TRD and SPL were less tolerable and significant improvements [10].

Oral appliances may improve upper airway patency during sleep by enlarging the upper airway or by decreasing upper airway collapsibility. The mechanism action of oral appliances is at least three ways. First, they bring the mandible and base of tongue forward. Second, they stabilize the mandible to prevent it from falling open during sleep. And third, they alter the mandibular position through downward rotation, thereby causing an increase in cross sectional airway size and muscle tone. After the oral appliance therapy, snoring is improved in 73% to 100% of patients [11]. Those patients with mild to severe OSA have a 52% chance of being able to control their sleep apnea to reach a level of AHI less than 10 by using oral

appliances [28]. Whole OAs are less effective than CPAP but may be better accepted by patients than CPAP in whom used both treatments. The common side effects of oral appliance such as excessive salivation, dryness of the mouth, or transient discomfort may prevent early acceptance. The major long-term problems are temporomandibular joint (TMJ), or jaw discomfort and limited movement of the teeth. Those effects can be minimized if the appliance is adjusted to so as to avoid excessive advancement of the mandible.

The standard treatments of snoring and OSA promoted by AASM include surgery, CPAP, and oral appliance. Among all of three, CPAP and oral appliance are noninvasive treatments. The CPAP is more effective than oral appliance, but the compliance of oral appliance is better than CPAP. Further, some drawbacks of CPAP in the equipment, interface, or appearance will lead to intolerable to use or inconvenience of usage in some occasions.

## III. PATENT ANALYSIS

The patent research is based on the patents published in the United States since 1976 that can be searched from the patent full-text and full-page image databases in the United States Patent and Trademark Office (USPTO). According to the patents, the development and trend in specific techniques can be realized. In this study, the aim of patent search focuses on the mechanisms of anti-snoring devices especially the mandibular advancement devices. Referring to the patent research, the analysis results can be classified into several categories by functions which will be discussed in following subsections. In general, patents are invented to improve the disadvantages existed in prior arts. The disadvantages refer to the analysis including uncomfortable to use, low compliance, high cost, cannot or complex to adjust, bulky volume, lack of customizability, and etc.

### A. Fixer

The function of the fixer is used to install the mandibular advancement device in the oral cavity by fixing on the teeth. The usage of most MADs is inserting into the mouth during sleep and removing after getting up. Because of the requirement of removability, the fixer is usually designed just to fit but not mount on the teeth. Thermoplastic materials are usually used to form the fixer like a mouthpiece. Some appliances add clasps on to make MAD more stable during wearing time. Finally, a little parts of MADs are fixed on the teeth by mounting directly. Those devices are usually used to treat the malocclusion, but the advancement also can eliminate snoring (Table I)

TABLE I  
FIXERS OF THE MAD

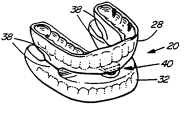
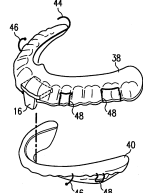
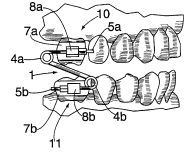
Thermoplastic material U.S. Patent: 5365945[12]	Clasp U.S. Patent: 5427117[13]	Mount directly U.S. Patent: 5645423[14]
		

**B. Connector**

In two-pieces MAD, connector connects the upper and lower mouthpiece adjustably. Different from the two-pieces MAD, the one-piece MAD which is entirely made by one material does not need the connector and cannot be adjusted. Therefore, all the MADs discussed here are the two-piece MAD which various connectors are used (Table II).

TABLE II  
CONNECTIONS OF THE MAD

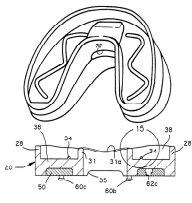
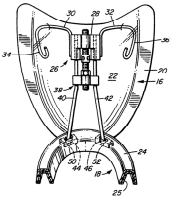
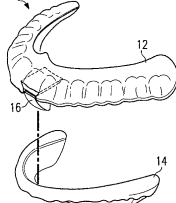
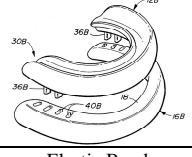
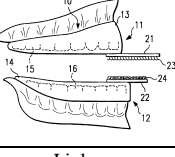
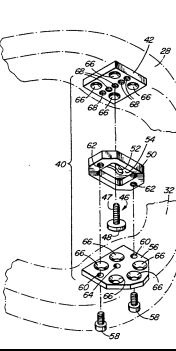
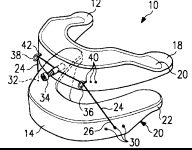
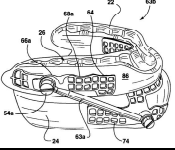
Button U.S. Patent: 5313960[15]	Wire U.S. Patent: 5409017[16]	Surface Contact U.S. Patent: 556683[17]
		
Post U.S. Patent: 5499633[18]	Interlocking member U.S. Patent: 5642737[19]	Mount directly U.S. Patent: 5365945[12]
		
Elastic Band U.S. Patent: 5755219[20]	Linkage U.S. Patent: 6418933[21]	
		

**C. Adjustor**

In aforementioned descriptions, connectors are used to connect the upper mouth piece and lower mouthpiece to form the MAD. The adjustor is either as a part of the connector or as an individual component to perform the function of adjustment. The way of adjustment can be divided into two types: continuous adjustment and position-fixed adjustment. The direction of adjustment makes the mandible not only protraction and retraction but also elevation and depression (TABLE III).

**D. Acting Force**

The force acting on mandible to advance it can be divided into the pulling force and the pushing force. The pulling force usually acts from the anterior portion of upper mouthpiece to the posterior portion of the lower mouth piece, the pushing force acts oppositely. However, most connectors are connected between the same portion of upper and lower mouthpiece. The force acts as a perpendicular force on the connector, and it is used to prevent the mandible backward which is similar to the pushing force. Therefore, the acting force includes perpendicular force, pushing force, and pulling force. In the mechanical terminology, they are shear force, compression force, and tensile force acting on the connector respectively (Table IV).

TABLE III  
ADJUSTORS OF THE MAD



Series of aperture U.S. Patent: 5365945[12]	Elastic band U.S. Patent: 5755219[20]	Dual-thread screw U.S. Patent: 5409017[16]
		
Conjugate shape U.S. Patent: 5570704[22]	Interlocking member U.S. Patent: 5642737[19]	Screw U.S. Patent: 6845774[24]
		
Slot U.S. Patent: 6305376[23]	Replace component U.S. Patent: 5427117[13]	
		

TABLE IV  
ACTING FORCE OF THE MAD

Perpendicular force U.S. Patent: 5365945[12]	Pushing force U.S. Patent: 6418933[21]	Pulling force U.S. Patent: 5755219[20]
		

**E. Lateral movement**

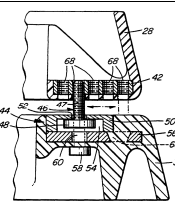
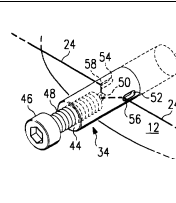
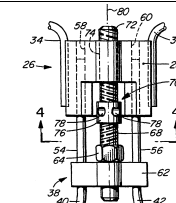
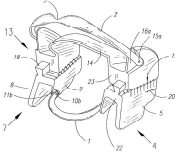
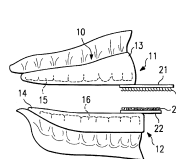
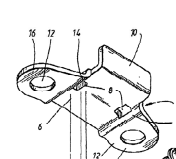
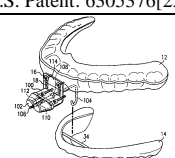
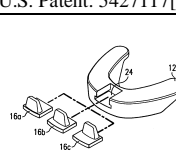
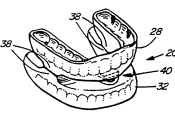
A function of allowing limited lateral movement during using the MAD is required. The lateral movement can prevent facial muscles from stiff and avoid the TMJ dysfunction. That will

make the patients feel more comfortable and tolerated in using the MAD. The methods which have promoted to patents include using slots, linkages, surface contact, and elastic bands. Using the slot and the linkage to perform this function are better than the surface contact and the elastic band. Because the slot and the linkage can limit the range of motion to ensure the therapeutic effect will not be affected by non-limited motion (Table V).

According to the patent reviews, more systematic results of analysis are presented. Those results can help to realize the disadvantages in prior products and find out the requirements. Further, those will be very useful for patent around that will prevent the new design from infringing other intelligence properties.

TABLE V  
LATERAL MOVEMENT OF MAD

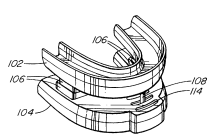
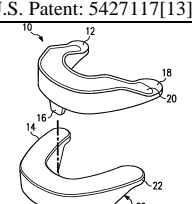
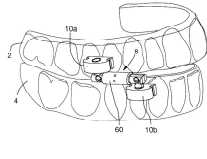
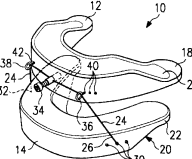
Slot U.S. Patent: 5868138[24]	Surface Contact U.S. Patent: 5427117[13]
	
Linkage U.S. Patent: 6012920[25]	Elastic band U.S. Patent: 5755219[20]
	

IV. CONCEPTUAL DESIGNS

There are still some problems existing in the commercial products. The most significant one is the failure of the MAD during the using time. The failure of the MAD will lead to the ineffective treatment and the extraneous expenses for repairing the device. Therefore, the problem here is to design a new MAD which will not break easily during the using time. The main function of the MAD is to make the jaw move forward to achieve the purpose of treating snoring and OSA. Thus the overall function in designing the MAD can be defined as: maintain the jaw position advancement. In according to the overall function, the functional decomposition proceeded to identify all the sub-functions, and the result is shown in Fig. 1.

The overall function is divided into several sub-functions by the consideration of the functions which should be included. The functional decomposition leads to a better understanding of the design problem. In the MAD, six primary sub-functions promote the effective work on treating snoring and OSA, which are the fixation of the MAD, the connection between both fixers, the adjustability of jaw advancement, the lateral movement of the jaw, the prevention of the device from breaking, and the force directions acting on the jaw.

After all the sub-functions have been developed, the next goal is to generate as many concepts as possible for each

sub-function. A popular method, brainstorming, is selected to generate concepts because of its advantage of gathering ideas from each group member in their own viewpoint. There are many combinations can be generated by combining individual concepts of each sub-function which described in the above section. However, some of them are impossible to be assembled together. Among the useful combinations, the relation between each individual concept should be good for arranging in pairs and without incompatible. In addition, some combinations are similar or almost the same with existent design or commercial products. At last, four complete concepts are picked out and listed in Table VI.

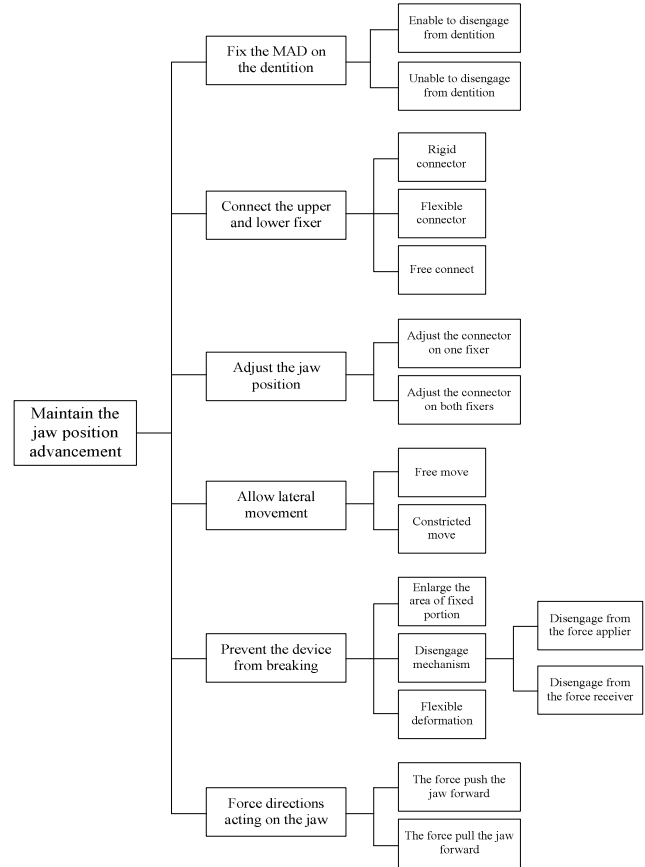
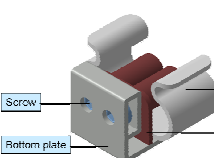
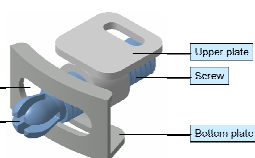
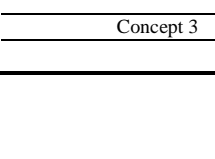
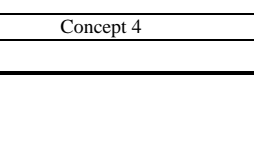
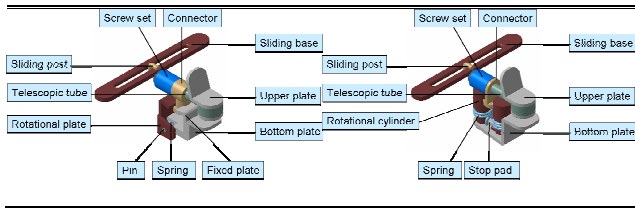

Fig. 1 Functional decomposition of the MAD

TABLE VI  
FOUR CONCEPTUAL DESIGNS

Concept 1	Concept 2
	
Concept 3	Concept 4
	



After four concepts have been generated, decision-matrix method [51] is used to evaluate these concepts. In the decision matrix (TABLE VII), several items should be included, such as criteria, importance, alternatives, evaluation of each alternative using criterion, and the final score for each alternative. The criteria are selected from the customer requirements by five dentists. The importance item in the decision matrix refers to the importance of customer requirements in QFD to calculate the weighting for each criterion by binary-matrix method [52]. The alternatives here are the four concepts described above. Before starting to evaluate, choose one concept as a datum for comparison. All other concepts are compared with the datum by judging each criterion, resulted in superior, the same, or inferior to the datum, and represented by symbol “+”, “S”, and “-“ respectively. Finally, compute the sum of the plus scores and minus scores which have been multiplied by the importance weightings.

TABLE VII  
DECISION MATRIX FOR FOUR CONCEPTS

Criteria (Requirements)	Importance (%)	Concept 1	Concept 2	Concept 3	Concept 4
1 Adjustable in front-rear direction	1.08	-		-	-
2 Adjustable in up-down direction	0.00	S		S	S
3 Mandible advance correctly	1.08	S		S	S
4 Lateral movement	1.43	S		+	+
5 Wear by oneself	7.53	S		S	S
6 Custom made	8.24	S		S	S
7 Distribute force caused by bruxism	3.58	+		+	+
8 Easy to adjust	7.17	-		S	S
9 Easy to wear into mouth	6.45	-		+	+
10 Easy to remove from mouth	6.09	-	DATUM	+	+
11 Avoid exaggeration of opening of jaw	3.23	-		+	+
12 Use for a long time	5.38	+		+	+
13 Comfortable to use	7.89	+		+	+
14 Simple operational steps to wear	2.51	-		+	S
15 Opening mouth is allowed	0.72	-		S	S
16 No Impingement of tongue space	2.15	+		-	-
17 Not irritate oral tissues	7.17	+		+	+
18 Easy to clean	2.87	+		S	S
19 Difficult to disengage from dentition	4.30	S		S	S
20 Without side effects	4.30	+		+	+
21 Structure of	2.15	-		-	-

mechanism is simple					
22 Long life	5.02	+		+	-
23 Tiny size	4.66	+		S	S
24 Difficult to break	5.02	+		+	+
Total +	48.04	-		58.07	50.54
Total -	29.40	-		5.38	10.4
Summation	18.64	-		52.69	40.14

After the evaluation by the decision-matrix, the concept 3 is presented as the best design which bases on the customers' requirements. The result exhibits that concept 3 is good at the lateral movement which confirms to the real condition, the small height of whole assembly, the functions to promote comfort, the easy operation process, and so on.

## V. CONCLUSIONS

Snoring is not only a very prevalent phenomenon during sleeping time but also an extremely prevalent disorder that influence the health of snorer. The obstruction of breathing leads to many symptoms in nocturnal and daytime that causes the variation of physical condition, the reduction of work efficiency, and even the happening of an accident. Therefore, the treatment of snoring is important. Based on the reviews of medical literatures, the MAD has been approved as an effective therapy for snoring and mild to moderate OSA.

The patent analyses of MADs assist the realization of the techniques and developments of the MAD which provide plenty information for consulting in the later procedures of design. In the conceptual design phase, four concepts are proposed in the end of the conceptual design procedure. Moreover, the disengagement function and a combination design which integrates adjustment and lateral movement functions are proposed. Finally, concept 3 is evaluated as the best concept between all of the concepts by preceding the decision-matrix method.

In the future, the prototypes of the final design can be manufactured after all of the dimensions are decided. Dimension optimization is recommended for the final design to reduce the size and to obtain the optimum strength. The clinical experiments are required to verify the efficacy of therapy by using the prototype.

## REFERENCES

- [1] Will Beachey, *Respiratory Care Anatomy and Physiology: Foundations for Clinical Practice*, Mosby, Inc., St. Louis, 1998.
- [2] Des Jardins, Terry R., *Cardiopulmonary Anatomy & Physiology: Essentials for Respiratory Care, 4th ed.*, Albany Delmar Thomson Learning, Australia, 2002.
- [3] Elaine N. Marieb, Jon Mallatt, *Human anatomy*, The Benjamin/Cummings Publishing Company, Inc., Redwood City, California, 1992.
- [4] David N. F. Fairbanks, Samuel A. Mickelson, and B. Tucker Woodson, *Snoring and Obstructive Sleep Apnea, 3rd ed.*, Lippincott Williams & Wilkins, Philadelphia, 2003.
- [5] Standards of Practice Committee, American Sleep Disorders Association, "Practice Parameters for the Treatment of Obstructive Sleep Apnea in Adults: The Efficacy of Surgical Modifications of the Upper Airway," *Sleep*, 19, 1996, pp.152-155.
- [6] Standards of Practice Committee, American Academy of Sleep Medicine, "Practice Parameters for the Use of Laser-Assisted

- Uvulopalatoplasty: An Update for 2000," *Sleep*, 24(5), 2001, pp. 603-619.
- [7] Standards of Practice Committee, American Academy of Sleep Medicine, "Practice Parameters for the Use of Continuous and Bilevel Positive Airway Pressure Devices to Treat Adult Patients with Sleep-Related Breathing Disorders," *Sleep*, 29(3), 2006, pp.375-380.
- [8] Standards of Practice Committee, American Academy of Sleep Medicine, "Practice Parameters for the Treatment of Snoring and Obstructive Sleep Apnea with Oral Appliance: An Update for 2005," *Sleep*, 29(2), 2006, pp.240-243.
- [9] Glenn T. Clark, "Mandibular advancement devices and sleep disordered breathing," *Sleep Medicine Reviews*, 2(3), 1998, pp.163-174.
- [10] Barthlen G. M., Brown L. K., Wiland M. R., Sadeh J. S., Patwari J., Zimmerman M., "Comparison of three oral appliance for treatment of severe obstructive sleep apnea syndrome," *Sleep Medicine*, 1, 2000, pp.299-305.
- [11] Schmidt-Nowara W, Lowe A, Wiegand L, Cartwright R, Perez-Guerra F, Menn S, "Oral Appliances for the Treatment of Snoring and Obstructive Sleep Apnea: A Review," *SLEEP*, 18(6), 1995, pp.501-510.
- [12] Halstrom, "Adjustable dental appliance for treatment of snoring and obstructive sleep apnea," United State Patent Number: 5365945, Filed: Apr. 13, 1993.
- [13] Thornton, "Apparatus for prevention of snoring and improved breathing during sleep," United State Patent Number: 5427117, Filed: Sep. 29, 1993.
- [14] Collins, Jr, "Mandibular advancement appliance," United State Patent Number: 5645423, Filed: Jun. 10, 1994.
- [15] Tomasi, "Apparatus and method for reducing snoring and method of making same," United State Patent Number: 5313960, Filed: Nov. 4, 1992.
- [16] Lowe, "Mandible repositioning appliance," United State Patent Number: 5409017, Filed: Jan. 19, 1994.
- [17] Thornton, "Apparatus for prevention of snoring and improved breathing during sleep," United State Patent Number: 5566683, Filed: Mar. 24, 1995.
- [18] Fenton, "Anti-snoring device with adjustable upper and lower relational members," United State Patent Number: 5499633, Filed: Mar. 28, 1994.
- [19] Parks, "Device for alleviating snoring," United State Patent Number: 5642737, Filed: May. 6, 1996.
- [20] Thornton, "Device for improving breathing," United State Patent Number: 5755219, Filed: May. 14, 1996.
- [21] Strong, "Anti-snoring device and method of making same," United State Patent Number: 6418933, Filed: Jun. 15, 2001.
- [22] Buzzard RD, Buzzard LD, Kenyon PL, Agre BT, "Universal, user-adjustable oral cavity appliance to control snoring and reduce episodes of obstructive sleep apnea," United State Patent Number: 5570704, Filed: Dec. 20, 1994.
- [23] Thornton, "Device and Method For Improving Breathing," United State Patent Number: 6305376, Filed: May. 16, 2000.
- [24] Gaskell, "Dental device," United State Patent Number: 6845774, Filed: Apr. 5, 2001.
- [25] Woo, "Articulating connector for mandibular repositioning oral appliance," United State Patent Number: 6012920, Filed: Apr. 22, 1999.

**Tsung-yin Lin** received his MS and PhD in mechanical engineering from National Chiao Tung University. He is currently an associate professor at the National Defense University in Taiwan. His research interest is design optimization for mechanical parts. Fiber-optic and bicycle components are the application fields.