

# Optimal Placement and Sizing of SVC for Load Margin Improvement Using BF Algorithm

Santi Behera, M. Tripathy, J. K. Satapathy

**Abstract**—Power systems are operating under stressed condition due to continuous increase in demand of load. This can lead to voltage instability problem when face additional load increase or contingency. In order to avoid voltage instability suitable size of reactive power compensation at optimal location in the system is required which improves the load margin. This work aims at obtaining optimal size as well as location of compensation in the 39-bus New England system with the help of Bacteria Foraging and Genetic algorithms. To reduce the computational time the work identifies weak candidate buses in the system, and then picks only two of them to take part in the optimization. The objective function is based on a recently proposed voltage stability index which takes into account the weighted average sensitivity index is a simpler and faster approach than the conventional CPF algorithm. BFOA has been found to give better results compared to GA.

**Keywords**—BFOA, GA, SSVSL, WASI.

## I. INTRODUCTION

IN power systems voltage instability problems are caused by the heavily loaded operating situation and contingencies in the form of outage of lines, generators etc. [1]. Researchers in this field have worked to find out effective voltage stability indices to expect a voltage collapse scenario and established different kinds of such indices which can forecast either steady or dynamic state voltage stability conditions when the system is subjected to sudden load increase or face some contingencies [2]-[6]. To get a due weight to each index value a weighted average sensitivity index is formulated named as WASI. The simplicity and value obtained being very close to the desirable one and ease of computation of this index, has encouraged this work to consider it in formulating the problem. Moreover, voltage stability margin improved by suitably sizing and placing VAR compensating devices [7], [8]. The main issue of optimal size and location has been determined by several researchers after formulating the problem as an optimization problem [9]. In this regard, conventional algorithms like Sequential Quadratic Programming (SQP), Linear Programming (LP) and Interior point based methods [10]-[12] and intelligent search algorithms like Genetic Algorithm (GA), Particle Swarm Optimization (PSO) [13], [14], have been applied to solve the problem based on their merits over others. This work aims at

optimizing the suitable location and capacity of static VAR Compensation (SVC) in the IEEE 39-Bus New England power system so as increase the system load margin using bacteria foraging optimization algorithm.

The paper is organized in the following sections. In Section II, the problem formulation is explained and Section III informs about sensitivity analysis. In the same section, some preliminary work is carried out to determine the weak buses in the system. Section IV discusses BFOA and its algorithm steps. Similarly, in Section V simulation result and discussions are illustrated, whereas Section VI concludes the findings of the work.

## II. PROBLEM FORMULATION

The objective function consists of five objectives namely the active power loss, the system load margin, and three penalty factors respectively.

### A. Active Power Loss

The first objective is to minimize the total active power losses which can be expressed as:  $\min f_1 = P_{\text{loss}}(x, u) =$  Average values of Real Power Loss in the system for all  $i$  numbers of critical load bus power increase scenarios, where  $x$  is set of all the node voltages,  $V_n$  and node angles  $\delta_n$  and  $u$  is control variable vector comprising of the position and size of shunt VAR compensation in the system.

### B. Load Margin

Increasing the load margin in stressed operating condition is challenging as it may lead to voltage instability. For this, proper VAR reserve capacity is to be available for optimization. The second objective is to maximize load margin, can be expressed as

$$\max f_2 = \lambda_{\text{max}} = \max(\lambda) = (1/\min\{a_{ij}\}) \quad (1)$$

where,  $\{a_{ij}\}$  is a set of maximum values of load parameters  $\lambda_{\text{max}}$ , each for  $i$  numbers of critical load bus power increase scenarios.

### C. Penalty Factors

Three penalty factors are considered for formulating the objective function  $\min f_3 = Pf_1 =$  penalty factor for limit violation

$$Pf_1 = 10 * \text{abs}(\text{sign}(V_{\text{min}} - 0.9) - 1) + 10 * \text{abs}(\text{sign}(V_{\text{max}} - 1.1) + 1) \quad (2)$$

$\min f_4 = Pf_2$  penalty factor for limit violation

Santi Behera is with the Department of Electrical Engineering, VSSUT, Burla, Sambalpur, PIN-768018, India (phone: +91-8763353194; e-mail: bsanti.uce@gmail.com).

M. Tripathy is with the Department of Electrical Engineering, VSSUT, Burla, Sambalpur, PIN-768018, India (e-mail: manish\_tripathy@yahoo.co.in).

J. K. Satapathy is Vice-Chancellor, BPUT, Rourkela, India, (In-Leon from N.I.T., Rourkela).

$$pf_2 = 10 * abs(sign(trans_{max} - 15) + 1) \quad (3)$$

$Pf_3$  = penalty factor for limit violation

$$pf_3 = 10 * abs(sign(line_{max} - 20) + 1) \quad (4)$$

where,  $pf_1$ ,  $pf_2$ , and  $pf_3$  denote the average values of penalty factors related to minimum and maximum voltages, transformer capacity and line capacity limits respectively.

The constraints of the problem are considered as explained below.

#### D. Equality Constraints

The equality constraints are the active and reactive power balance described by a set of power flow equations which can be expressed in a compact form

$$G(x,u,\lambda)=0 \quad (5)$$

#### E. Inequality Constraints

The transformer apparent power  $S_T$ , line apparent power  $S_{line}$ , bus voltage magnitude  $V_L$ , generator VAR  $Q_G$ , and shunt compensator VAR  $Q_C$  are considered as

$$\begin{cases} S_{T_{min}} \leq S_{Ti} \leq S_{T_{max}}, & i = 1 \dots N_T \\ S_{T_{line_{min}}} \leq S_{T_{line}} \leq S_{T_{line_{max}}}, & i = 1 \dots N_{line} \\ V_{L_{min}} \leq V_{Li} \leq V_{L_{max}}, & i = 1 \dots N_L \\ Q_{G_{min}} \leq Q_{Gi} \leq Q_{G_{max}}, & i = 1 \dots N_G \\ Q_{C_{min}} \leq Q_{Ci} \leq Q_{C_{max}}, & i = 1 \dots N_C \end{cases} \quad (6)$$

The constraints are combined to form a compact form as

$$H(x,u,\lambda) \leq 0 \quad (7)$$

In collecting the constraints and the objectives the problem is expressed as

$$\begin{cases} \text{Minimize } F(x,u,\lambda) \\ \text{subject to } G(x,u,\lambda) = 0, \\ \text{and } H(x,u,\lambda) \leq 0 \end{cases} \quad (8)$$

$$F = (1 / \min\{a_{ij}\}) + P_{loss} + Pf_1 + Pf_2 + Pf_3 \quad (9)$$

The first and second parts of the objective functions formulated as in (9) take into account the improvement in voltage stability limit and real power loss minimization. Each part of the objective function is suitably scaled. The penalty factors  $pf_1$ ,  $pf_2$ , and  $pf_3$  give zero output unless limits are violated. The system loadability limit known as the Steady State Voltage Stability Limit (SSVSL) evaluated with a particular pattern of load increase, the load at the  $i^{th}$  load bus is increased in steps (with equivalent increase in generation as well) till the unstable point is reached. This is illustrated in (10)

$$\begin{aligned} P_{Li} &= P_{Li0} (1 + \lambda) \\ Q_{Li} &= Q_{Li0} (1 + \lambda) \\ P_{Gi} &= P_{Gi0} (1 + \lambda) \end{aligned} \quad (10)$$

where,  $\lambda$  is known as the load parameter, used to increase the real and reactive powers from their respective nominal values. The system SSVSL in this work is evaluated with the help of WASI as introduced in Section III. With the increase in load, WASI value reduces and becomes zero near the SSVSL. Hence the corresponding  $\lambda$  value is the SSVSL of the system. The problem is formulated as a static constrained non-linear optimization problem.

### III. SENSITIVITY ANALYSIS

In order to gain an insight into possible weak buses of the system and indices were evaluated, so that their values could throw some light on the choice of suitable location and size of compensation required by the system in the occurrence of load increase and contingencies. For this purpose four different indices known as Q-loss sensitivity index, L-index, and V-Q eigen value sensitivity index are enumerated separately for 17 load buses of the system. A weighted average sensitivity index (WASI) comprising the effects of all these indices are determined. The weakness bus rankings are obtained from WASI values. This approach helps to determine a worse case loading scenario in the system. The reader may please be referred for detailed mathematical equations for Q-Loss, L-index, and V-Q sensitivity index in literatures [1], [9].

#### A. Q-Loss Index

Power system network can be represented in a linearized form [7] as expressed in (11)

$$\begin{bmatrix} \Delta P \\ \Delta Q \end{bmatrix} = \begin{bmatrix} J_{11} & J_{12} \\ J_{21} & J_{22} \end{bmatrix} \begin{bmatrix} \Delta \theta \\ \Delta V \end{bmatrix} \quad (11)$$

The Q-loss sensitivity  $SI_1$  can be formulated as per

$$SI_1 = \frac{\partial Q_i}{\partial |V_i|} = [J_{22_{ii}}] \div |V_i| \quad (12)$$

For high value of  $\frac{\partial Q}{\partial |V_i|}$  the degree of weakness is less.

#### B. L-Index

L-Index for any  $j^{th}$  non-generator bus in a N-Bus system having  $g$  numbers of generators i.e.,  $1 \dots g$  and  $(g+1) \dots N$ ,  $(N-g)$  numbers of load buses can be evaluated by

$$SI_2 = L_j = \left| 1 - \sum_{i=1}^{i=j} F_{ji} \left( \frac{V_i}{V_j} \right) \right| \quad (13)$$

where, the elements  $F_{ji}$  can be evaluated from the Y-bus matrix of the system as depicted by

$$\begin{bmatrix} I_G \\ I_L \end{bmatrix} = \begin{bmatrix} Y_{GG} & Y_{GL} \\ Y_{LG} & Y_{LL} \end{bmatrix} \begin{bmatrix} V_G \\ V_L \end{bmatrix} \quad (14)$$

$$\begin{bmatrix} V_L \\ V_G \end{bmatrix} = \begin{bmatrix} Z_{LL} & F_{LG} \\ K_{GL} & Y_{GG} \end{bmatrix} \begin{bmatrix} I_L \\ I_G \end{bmatrix} \quad (15)$$

where,

$$F = -[Y_{LL}]^{-1}[Y_{LG}] \quad (16)$$

*C. V-Q Index*

The eigenvalue sensitivity index can be estimated using (17) as

$$SI_3 = \frac{\partial V_k}{\partial Q_k} = \sum_i \frac{\xi_i \eta_{ik}}{\lambda_i} \quad (17)$$

where,  $\xi_i = i^{th}$  column right eigenvector,  $\eta_i = i^{th}$  row left eigenvector matrix of  $J_R$  and  $\lambda_i = i^{th}$  eigenvalue .

*D. Weighted Average Sensitivity Index (WASI)*

The WASI is defined as

$$WASI = (SI_1 \times w + SI_2 \times w + SI_3 \times w + \dots SI_n \times w) / n \times w \quad (18)$$

where,  $w$  is weighing factor. Though any value may be chosen in this work but here it is taken as 0.5.  $SI_1 SI_2 SI_3 \dots SI_n$  are the indices.

**IV. BACTERIA FORAGING ALGORITHM: AN OVERVIEW**

Bacteria Foraging Optimization Algorithm (BFOA) proposed by [14] is a unique parallel search algorithm based on the foraging attributes of a type of bacterial species present in human intestine known as *E. coli*. The foraging process of each of this bacterium is defined by four processes known as Chemotaxis, Swarming, Reproduction and Elimination & Dispersal. The details of the algorithm steps of the original version as proposed by [14] and the modified version [13] are explained in the respective works. The steps involved for the simulation which are as follows:

- Step 1. Gradually increase the load in the load bus in steps.
- Step 2. Check the index value in each step.
- Step 3. Do weakness ranking in the buses.
- Step 4. Select 5 weak buses only.
- Step 5. Consider two shunt VAR compensators and two locations for optimizations
- Step 6. Perform optimization with GA
- Step 7. Again perform optimization with BFOA

The detailed enumeration and results for the considered test system are discussed in Section V.

**V. SIMULATION RESULTS AND DISCUSSIONS**

*A. Test System*

In this paper the study carried out on 10-machine, 39-bus New England power system [14]. The system has 46 transmission lines, twelve transformers. The 1<sup>st</sup> generator ( $G_1$ )

is an equivalent representation of the U.S.-Canadian interconnection system shown in Fig. 1.

Initially, the weak buses in the test system are evaluated with the help of three different sensitivity indices discussed in section III. The WASI for the load buses is obtained with gradual load increase in steps of 2% increment. The values obtained for the different indices are shown in Table I. The load buses are ranked in the descending order of weakness. For the purpose of optimization, loads in top five weakest buses in the system mentioned in Table II are subjected to load increase till their respective WASI values reach the unstable mark of zero. Load increase scenario in all these buses are simulated first by keeping the reactive power (Q) constant and then by keeping their nominal value Power Factor (PF) constant. To determine the maximum loadability of the system, the minimum value of  $\{a_{ij}\}$  is defined in section II obtained by loading each of the five weakest buses is maximized.

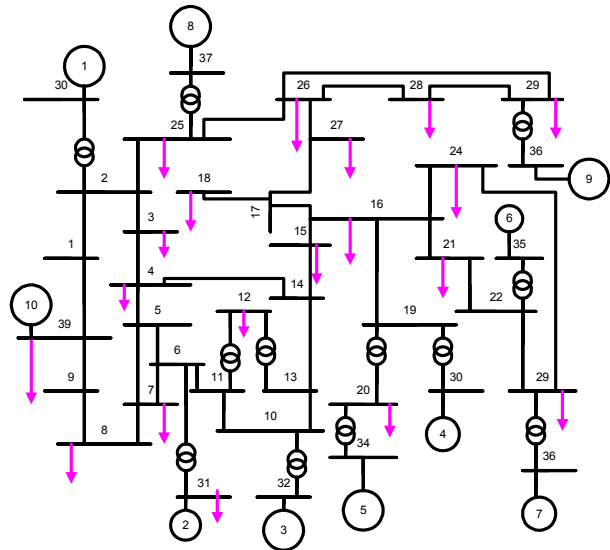

Fig. 1 IEEE-39 Bus Structure

*B. Optimization with GA*

Simple conventional GA is adopted for optimization. The crossover and mutation probabilities are assumed to be 0.85 and 0.05 respectively. The location and amount of reactive power compensation at two locations are randomly initialized. All the top 17 numbers of weak buses are considered as candidates for compensation and two out of them are randomly chosen with randomly generated compensation amount in the range of -40% to +40%. The optimized results are shown in Table III.

*C. Optimization with BFOA*

The same philosophy as discussed above was again adopted with BFOA. The control parameters for BFOA are judiciously chosen. Four numbers of bacteria evolve in the optimization process consisting of 4 chemotactic stages. The values of run length unit and elimination probability are considered as 0.05 and 0.25 respectively. Simulations were carried out with both

the above algorithms. The convergence characteristics obtained with these algorithms for both constant Q (Case 1) and constant power factor types (Case 2) of load shown in Figs. 2 and 5 respectively, depicts the supremacy of BFOA over GA.

Though, the objective function values are obtained with both GA and BFOA are almost similar to each other, but GA has fared quite badly in terms of limiting constraints violation. The optimization results are depicted in Table III. The WASI values obtained at each step of load increase till the point of instability. Similarly all the bus voltage profiles at the last stable loading point are depicted in Figs. 3 and 6 for both the cases. The two optimization results were obtained for the percentage compensation of reactive VAR required and compared as shown in Figs. 4 and 7 respectively. The results of optimal VAR compensations in percentage values obtained from both optimization techniques are shown in Fig. 8. The comparison of the three indices with WASI is depicted in Fig. 9. The WASI value gives more accurate indication of the weakness of the system.

TABLE I  
SENSITIVITY INDEX ANALYSIS

V-Q Index	Bus No	Q-Loss Index	Bus No	L-Index	Bus No	WASI	Bus No
0.0075	02	0.0054	01	0.0085	23	0.0136	20
0.0084	19	0.0001	02	0.0093	20	0.0146	08
0.0090	25	0.0070	09	0.0104	07	0.0186	29
0.0097	22	0.0116	25	0.0109	08	0.0187	27
0.0106	06	0.0160	29	0.0150	06	0.0192	28
0.0107	10	0.0173	28	0.0188	22	0.0197	22
0.0107	20	0.0187	22	0.0210	09	0.0239	09
0.0110	23	0.0219	20	0.0220	05	0.0245	05
0.0114	16	0.0221	26	0.0260	21	0.0294	01
0.0116	05	0.0252	10	0.0287	12	0.0304	11
0.0117	11	0.0259	19	0.0303	15	0.0333	04
0.0119	03	0.0276	03	0.0307	24	0.0348	24
0.0125	13	0.0319	13	0.0307	01	0.0350	15
0.0127	29	0.0325	11	0.0308	11	0.0351	02
0.0129	17	0.0387	05	0.0329	04	0.0358	14
0.0132	04	0.0400	23	0.0361	14	0.0359	13
0.0133	14	0.0409	04	0.0367	16	0.0359	10
0.0147	18	0.0409	27	0.0379	13	0.0370	16
0.0148	24	0.0413	06	0.0398	10	0.0374	21
0.0150	08	0.0419	18	0.0420	03	0.0382	03
0.0154	07	0.042	14	0.0428	18	0.0404	12
0.0160	15	0.0424	12	0.0437	02	0.0413	18
0.0160	26	0.0458	08	0.0438	17	0.0417	17
0.0162	01	0.0474	07	0.0508	29	0.0440	07
0.0172	09	0.0493	17	0.0529	27	0.0448	25
0.0185	27	0.0632	16	0.0548	25	0.0503	23
0.0217	28	0.0682	15	0.0583	28	0.0538	06
0.0260	21	0.0693	24	0.0653	26	0.0562	19
0.0342	12	0.0765	21	0.0693	19	0.0566	26

TABLE III  
WEAK BUS RANKING

WASI Value	Bus No.	Rank
0.0136	20	1
0.0187	8	2
0.0448	29	3
0.0503	27	4
0.0562	28	5

TABLE III  
OPTIMIZED COMPENSATION RESULTS WITH GA AND BFOA

Compensation Specifications	Case 1 (Constant Q-Load)		Case 2 (Constant pf-Load)	
	GA	BFOA	GA	BFOA
1 <sup>st</sup> Location	Bus No. 28	Bus No. 24	Bus No. 27	Bus No. 15
1 <sup>st</sup> Amount	43.35%	43.78%	33.55%	17.82%
2 <sup>nd</sup> Location	Bus No. 20	Bus No. 15	Bus No. 18	Bus No. 27
2 <sup>nd</sup> Amount	31.57%	08.68%	12.63%	40.05%
Obj. Function Value	0.7106	0.5058	0.7273	0.7196
Constraint	48.52	28.72	49.31	47.63
QQ	2.1402	2.3162	2.3078	2.2428

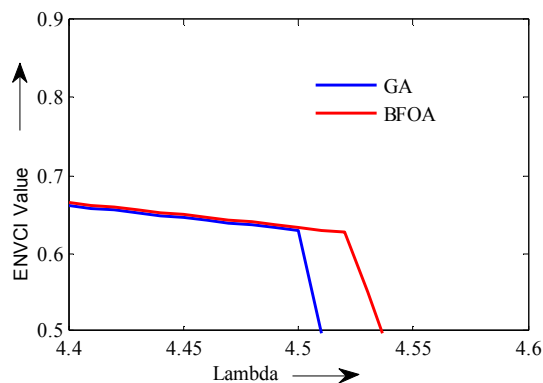

Fig. 2 Convergence characteristics for the constant reactive power with increased active power

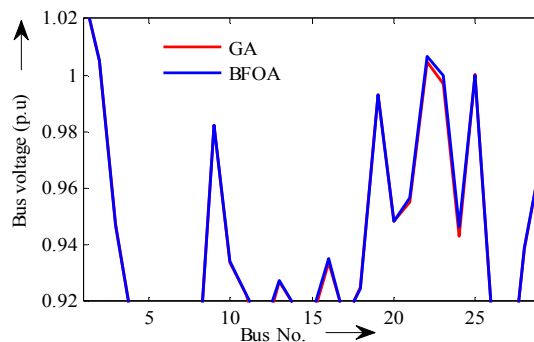

Fig. 3 Bus voltage profiles obtained with constant reactive power

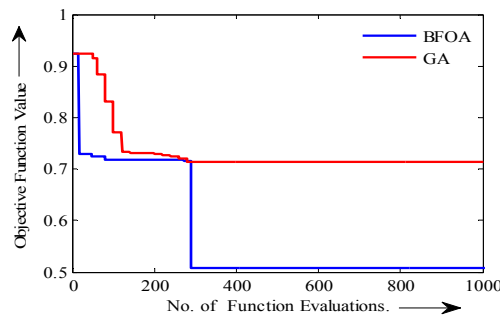

Fig. 4 Load margin for constant reactive power

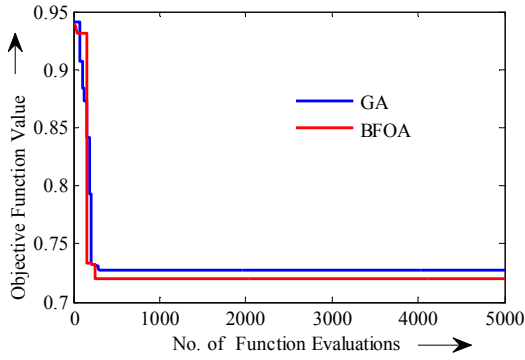

Fig. 5 Convergence characteristics for constant power factor

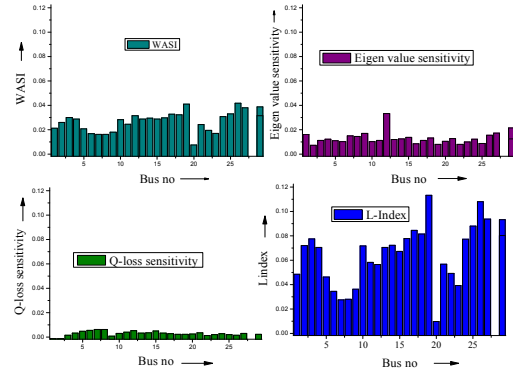

Fig. 9 Comparisons of indices

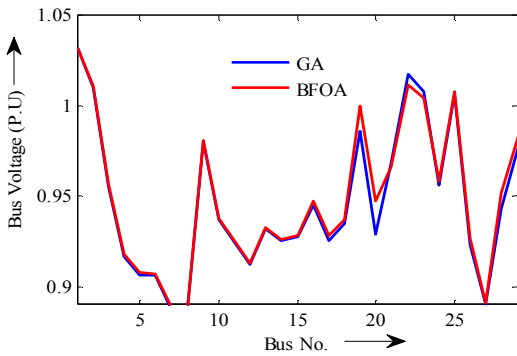

Fig. 6 Voltage profiles for constant power factor

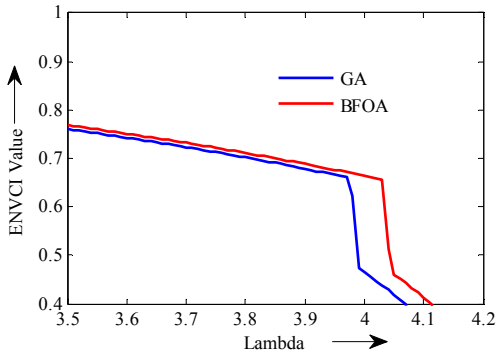

Fig. 7 Load margin for constant power factor

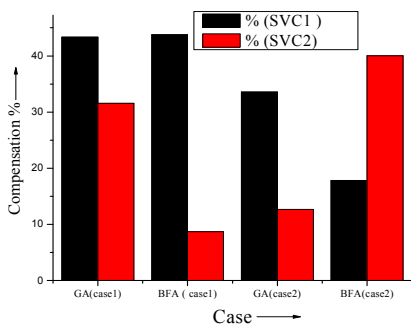

Fig. 8 Compensation (%) in two cases with GA and BFOA

## VI. CONCLUSIONS

In this work two effective locations and sizes of reactive power compensation was evaluated to improve the steady state SSVSL of 39-Bus New England system. The SSVSL is determined from an equivalent network based system model and it can be utilized for online implementation. The problem was formulated as a non linear optimization problem with a suitably designed objective function, which takes into account real power loss minimization in the system as well. The objective function is optimized by using GA and BFOA. Results show the supremacy of BFOA over GA handling the desired constraints. To reduce the number of control variables, initially weak buses in the system are identified which helps in reducing the computational time.

## REFERENCES

- [1] T. V. Cutsem, and C. Vournas, "Voltage Stability of Electric Power Systems", Norwell, M. A. Kuwer, 1998.
- [2] Zhihong Feng, Venkataramana Ajarapu, and Dominic J. Maratukulam, "A Comprehensive Approach for Preventive and Corrective Control to Mitigate Voltage Collapse", *IEEE Trans. Power Systems*, vol. 15, no. 2, May 2000, pp. 791-797.
- [3] Fernando L. Alvarado, Jianping Meng, Christopher L. De Marco, and Wellington S. Mota, "Stability Analysis of Interconnected Power Systems Coupled with Market Dynamics", *IEEE Trans. Power Systems*, vol. 16, no. 4, Nov. 2001 pp. 695-701.
- [4] M. V. Reddy, Yemula Pradeep, V. S. K. Murthy Balijepalli, S.A. Khaparde, and C. V. Dobarra, "Improvement of Voltage Stability Based on Static and Dynamic Criteria", in *Proceedings of 16th National Power Systems Conference*, 15th-17th Dec, 2010, pp.715
- [5] Kundur P, *Power System Stability and Control*, McGraw-Hill, 1994
- [6] Shraddha Udgir, Sarika Varshney, and Laxmi Srivastava, "Optimal Placement and Sizing of SVC for Voltage Security Enhancement", *International Journal of Computer Applications*, vol 32, no.6, October 2011, pp. 44-51.
- [7] Zhihong Feng, Venkataramana Ajarapu, and Dominic J. Maratukulam, "A Comprehensive Approach for Preventive and Corrective Control to Mitigate Voltage Collapse", *IEEE Trans. Power Systems*, vol. 15, no. 2, May 2000, pp.791-797.
- [8] M. Nanba, Y. Huang, T. Kai and S. Iwamoto, "Studies on VIPI based control methods for improving voltage stability", *Electrical Power & Energy Systems*, vol. 20, no. 2, 1998, pp. 141-146.
- [9] D. Thukaram, and Abraham Lomi, "Selection of static VAR compensator location and size for system voltage stability improvement," *Electric Power Systems Research*, vol. 54, 2000, pp. 139-150.
- [10] Wei Yan, Juan Yu, David C. Yu, and Kalu Bhattarai, "A New Optimal Reactive Power Flow Model in Rectangular Form and its Solution by

- Predictor Corrector Primal Dual Interior Point Method”, *IEEE Trans. Power Systems*, vol. 21, no. 1, Feb. 2006, pp. 61-67.
- [11] Kenji Iba, “Reactive Power Optimization by Genetic Algorithm”, *IEEE Trans. Power Systems*, vol. 9, no. 2, May 1994, pp. 685-691.
- [12] M. Kowsalya, K. K. Ray and D. P. Kothari, “Loss Optimization for Voltage Stability Enhancement Incorporating UPFC Using Particle Swarm Optimization”, *Journal of Electrical Engineering & Technology*, vol. 4, 2009, pp.492- 498.
- [13] M. Tripathy, and S. Mishra, “Bacteria Foraging based solution to optimize both real power loss and voltage stability limit”, *IEEE Trans. Power Systems*, vol. 22, no. 1, Feb. 2007, pp. 240-248.
- [14] K. M. Passino, “Biomimicry of bacterial foraging for distributed optimization and control”, *IEEE Control System*, June-2002, pp.52-67.



**Santi Behera** received B.Tech degree in Electrical Engg. from College of Engineering and Technology, Bhubaneswar, India, in 1995, and worked as Guest Faculty in UCE, Burla. She completed M.Tech in 2000 from UCE (Now VSSUT), Burla. She has joined VSSUT as a Lecturer in 2001 and now continuing as Asst. Professor (Power Engineering) in the same University. She is doing her PhD in power system stability in NIT, Rourkela. Her field of interest is application of artificial intelligence in power system operation.



**M. Tripathy** received the B.E. degree from N.I.T. (Formerly Regional Engineering College), Rourkela, India, in 1991, and worked in Industry for five years before completing M.E. from VSSUT (Formerly University College of Engineering), Burla in the year 2001. He completed Ph.D. from Indian Institute of Technology, Delhi, India in the year 2009. He has been a faculty in the Department of Electrical Engineering at VSSUT, Burla in different capacities as Lecturer during 2006-2010 and as a Reader since 2010. His field of interest is application of intelligent techniques to power system operation and control and wind integrated power systems.



**J. K. Satapathy** (Member of IEEE) was born in 1954. Prof. Satapathy topped his batch in 1976 in BSc (Engg.) with 85.8 per cent marks. He then completed his MSc (Engg.) in 1981 with specialization in Electric Power. In 1988, he got his PhD in Electrical Engineering from the University of Bradford, UK. He has also worked as guest and invited faculty for foreign universities. He joined NIT Rourkela in 1989 as a faculty and also promoted to the post of Professor in Electrical Engineering till 2010. He has joined as the vice-chancellor of the Biju Patnaik University of Technology (BPUT), Rourkela in 2010 and continuing till date. For presenting research papers and academic works, Prof. Satapathy has visited the UK, USA, Singapore, Japan and Australia. His fields of specialization include power systems, power electronics and drives, harmonic interaction in power systems, digital protection, digital signal processing, digital channel equalisation and system identification