

Optimal Allocation of FACTS Devices for ATC Enhancement Using Bees Algorithm

R.Mohamad Idris, A.Khairuddin, and M.W.Mustafa

Abstract—In this paper, a novel method using Bees Algorithm is proposed to determine the optimal allocation of FACTS devices for maximizing the Available Transfer Capability (ATC) of power transactions between source and sink areas in the deregulated power system. The algorithm simultaneously searches the FACTS location, FACTS parameters and FACTS types. Two types of FACTS are simulated in this study namely Thyristor Controlled Series Compensator (TCSC) and Static Var Compensator (SVC). A Repeated Power Flow with FACTS devices including ATC is used to evaluate the feasible ATC value within real and reactive power generation limits, line thermal limits, voltage limits and FACTS operation limits. An IEEE30 bus system is used to demonstrate the effectiveness of the algorithm as an optimization tool to enhance ATC. A Genetic Algorithm technique is used for validation purposes. The results clearly indicate that the introduction of FACTS devices in a right combination of location and parameters could enhance ATC and Bees Algorithm can be efficiently used for this kind of nonlinear integer optimization.

Keywords—ATC, Bees Algorithm, TCSC, SVC

I. INTRODUCTION

IN recent years, power system operation faces new challenges due to deregulation and restructuring of the electricity markets. The old system known as monopoly based are substituted by a competitive marketplace. Hence the new structures of power system become more complex. These new structures have to deal with problem raised by the difficulties in building new transmission lines and the significant increase in power transactions associated to competitive electricity markets. Thus a large interconnected system has been built in order to be able to obtain a high operational efficiency and network security. In this situation, one of the possible solutions to improve the system operation is the use of flexible ac transmission technologies (FACTS).

The implementation of the FACTS devices extends the possibility that current through a line can be controlled at a reasonable cost, enabling large potential of increasing the

capacity of existing lines, and use of one of the FACTS devices to enable corresponding power to flow through such lines under normal and contingency conditions. Several studies [1]-[3] have found that FACTS technology not only provides solutions for efficiently increasing transmission system capacity but also increases ATC, relieve congestion, improve reliability and enhances operation and control. However, it is hard to determine the optimal allocation and parameters of FACTS devices due to the complicated combinatorial optimization. Thus, attention is paid in this current work to study a technique to optimally allocate the devices to enhance ATC.

The task of calculating ATC is one of main concerns in power system operation and planning. ATC is determined as a function of increase in power transfers between different systems through prescribed interfaces. In this research, the ATC is calculated using Repetitive Power Flow (RPF) and the effectiveness of the devices to enhance ATC is investigated using sample 3 bus system and IEEE30 bus test systems.

The problem formulation in this research is a nonlinear mixed integer which requires a complex optimization tool to solve the allocation problem. For this purpose, a new algorithm called Bees algorithm is proposed to optimally allocate the devices in the system effectively in order to achieve the objective function.

This paper is divided into several sections. Section II elaborates the related works regarding conventional methods in allocating FACTS devices. Section III presents mathematical model of the FACTS Devices. Section III describes the problem formulation while Section IV performs the background theory and the procedures of Bees algorithm to allocate FACTS devices. The simulation results are presented and discussed briefly in Section VI. Section VII concludes the paper.

II. RELATED WORKS

A. Optimal Allocation of FACTS Devices

Many studies have been made on the optimal allocation of FACTS devices for static performances. The conventional methods on the optimal allocation of FACTS that are based on the population-based search algorithm (GA, PSO, ES, EP), concepts of artificial intelligence (Tabu Search-TS), and physical environmental process (Simulated Annealing-SA) can be classified as metaheuristics method.

(i) Metaheuristics Method

R.Mohamad Idris is with the Electrical Engineering Department, University Teknologi Malaysia, Skudai, Johor, Malaysia (corresponding author to provide phone: 607-5535801; fax: 607-5566 272 ; e-mail: rasyidah@fke.utm.my).

A.Khairuddin, is with Electrical Engineering Department, University Teknologi Malaysia, Skudai, Johor, Malaysia (corresponding author to provide phone: 607-5535369; fax: 607-556-6272; e-mail: azhar@fke.utm.my).

M.W.Mustafa is with Electrical Engineering Department, University Teknologi Malaysia, Skudai, Johor, Malaysia (corresponding author to provide phone: 607-5535368; fax: 607-556-6272; e-mail: wazir@fke.utm.my).

There are several metaheuristic methods that have been used for optimal allocation of FACTS devices. Among them are, Simulated Annealing (SA) [8], Tabu Search (TS) [8], Genetic Algorithm (GA) [4-13], Evolutionary Programming (EP) [14], Evolutionary Strategies (ES)[15] and recently many researchers focus on Particle Swarm optimization (PSO) [16,17].

SA is analogies to the heat bath in a way that a parameter called temperature is introduced to shrink the search space. The method is time consuming to evaluate a solution even though it has a function to escape from a local minimum with probability. GA in the other hand, are general-purpose search algorithms based upon the principles of evolution observed in nature. Genetic algorithms combine selection, crossover, and mutation operators with the goal of finding the best solution to a problem. Genetic algorithms search for this optimal solution until a specified termination criterion is met. It gives better results in small –scale problems, but it does not work so well in large scale systems. It is hard to evaluate appropriate parameters in large scale problems.

TS is based on deterministic search that uses adaptive memory called tabu list to escape from a local minimum. Compared to SA and GA, TS performs faster to find out better solution for given iteration. This algorithm is the transition type algorithm that stores better solution during the search process instead of the convergence type like SA and GA. However, the drawbacks of TS are, (i) it is not easy to evaluate the candidates in the neighborhoods of TS when the problem size is larger and (ii) the large scale problem requires variety of search process where it requires multi point search space.

EP and ES are the computational optimization methods which use the mechanic of evolution to find the global optimal solution of complex optimization. They work by evolving a population candidate toward the global solution through the use of mutation and selection scheme. The only difference between both methods is in recombination and mutation type.

In [4], GA have been used for allocation of SVC to achieve optimal power flow without any constraints violation and thus to increase the utilization of the lowest cost generation in power system. In [5], GA have been used to optimized multi-type of FACTS; TCSC, SVC and UPFC to improve the power system security. The cost function of FACTS and power losses are considered in this algorithm. In [12], Shaheen et al, proposed GA to optimally allocate UPFC for effectively controlling power flow and regulating bus voltage in electrical power system, resulting in an increased transfer capability, low system losses, and improved stability.

In [10], *Ippolito et al*, proposed methodology based on GA to identify the optimal number and location of UPFC in an assigned power system network for maximizing system capabilities, social welfare, and to satisfy contractual requirements in an open market. On the hand, in [11], Multi-Objective GA (MOGA) was proposed by *Radu et al* to optimally allocate TCSC and SVC to maximize the power system security and minimize the total investment cost of FACTS. In [13], *L.J Cai* proposed GA to optimally allocate

multi-type of FACTS; TCSC, SVC, TCPS and UPFC. The proposed method could find the parameters, type and rated value of facts in order to minimize the overall system cost function: generation cost and FACTS investment cost. Nevertheless, none of the papers mentioned above has investigated the allocation of FACTS to enhance ATC. Moreover, none of them show the robustness of the system in the large scale problems.

In [14], Evolutionary Programming was used to determine the optimal allocation of FACTS for maximizing TTC between sources and sink area. Four types of FACTS are included in the studies; TCSC, UPFC, TCPS and SVC. The inequality constraints are power generation limit, voltage limit, line flow limit and facts operation limit. In [15], only three types of FACTS; TCSC, SVC and TCPS were used to perform the effectiveness of ES. Three important aspects of FACTS to be considered throughout the optimization were the types of FACTS controller used, rated value and its location. The algorithm demonstrates the effectiveness of FACTS to improve system loadability. Yet in [14, 15], no consideration has been given in comparing the proposed method with other optimization methods to show the robustness of the proposed methods.

So Far, only *Gerbex et al* [8] has presented the effectiveness of TS in optimally allocating FACTS devices. FACTS are located in the system to enhance system security where three parameters of FACTS being considered; location, type and size of FACTS. Nevertheless, none has considered this method in enhancing ATC.

PSO has shown a great promise in power system optimization problems [16-17]. The PSO mimics the behavior of individuals in a swarm to maximize the survival of species. In PSO, each individual decides based on its own experiences as well as other individuals' experiences [17]. The algorithm searches a space by adjusting the trajectories of moving points in a multidimensional space. PSO, GA and EP are all work in the same way, updating the position of individuals by applying some kinds of operators according to the fitness, so that the individuals of the population can be expected to move towards better solution area. However, unlike GA and EP, each individual in PSO flies in search space with a velocity which is dynamically adjusted according to its own flying experience and its companions flying experiences. Furthermore, in PSO the selection operator is not performed. All particles in PSO are kept as members of the population through the course of run. The velocity of the particles is updated according to its own previous best position and the previous best positions of its companions. PSO is the only evolutionary algorithm that does not implement survival of the fittest. The main merits of PSO are its fast convergence speed and it can be realized simply for less parameters need adjusting.

In [16], PSO technique is used to find optimal location of FACTS to achieve maximum system loadability with minimum cost of installations of FACTS. The combinations of multi-type of FACTS were considered with line thermal limit and bus voltage limit as their inequality constraints. While in [17] only STATCOM has been used to perform the

effectiveness of PSO in allocating the devices. In this paper, the STATCOM is placed to improve voltage profile, minimize power system total losses and maximize system loadability with respect to the size of it. Yet in [16-17] no consideration has been taken in maximizing ATC. Furthermore, no comparison has been made in showing the robustness of the method with other existing methods. None has shown so far the used of TCPS in improving the system loadability using PSO.

As a compared to other methods, Bees Algorithms is a new term in optimization world. The Bees Algorithm [18] is a population-based search algorithm first developed in 2006. It mimics the food foraging behaviour of swarms of honey bees. In its basic version, the algorithm performs a kind of neighbourhood search combined with global search and can be used for both combinatorial optimisation and functional optimisation.

III. FACTS MODEL

A. FACTS Devices

Two types of FACTS have been used in this study namely; Static Var Compensator (SVC) and Thyristor Control Series Compensator (TCSC). The block diagrams of the devices are shown in Figure 1.

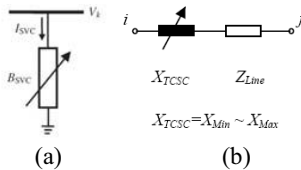

Fig.1: Block diagram of the (a) SVC (b) TCSC

B. Mathematical Model of FACTS Devices

1) SVC

The SVC is a shunt connected static var generator or absorber. The SVC can be used to control the reactive compensation of a system. B_{SVC} represents the controllable susceptance of SVC. It can be operated as inductive or capacitive compensation. In this study, it is modeled as an ideal reactive power injection at bus i , at where it is connected. The working range of SVC is between -100 MVar and 100 MVar [13].

2) TCSC

The TCSC changes the line reactance. It can be inductive or capacitive compensation respectively by modifying the line reactance. The reactance of TCSC is adjusted directly based on the reactance of the transmission line.

$$X_{ij} = X_{line} + X_{TCSC} = r_{TCSC} \cdot X_{line}$$

Where X_{line} is the reactance of the transmission line, X_{TCSC} represents the reactance contribute by TCSC and r_{TCSC} represents the degree of compensation of TCSC. The working range of TCSC ($X_{MIN} \sim X_{MAX}$) is set between -0.7 X_{line} and 0.2 X_{line} [13].

IV. PROBLEM FORMULATION

The main objectives of this work is to determine the optimal location and the optimal parameter setting of the FACTS device in the power network to maximize the available power that can be transferred from a specific set of generators in a source area to loads in sink area, subject to real and reactive power generation limits, voltage limits, line thermal limits and FACTS devices operation limits.

The RPF with FACTS devices is used to evaluate the feasible ATC value of the power transactions. RPF is based on generalized search method, where successive power flow solution is performed until it reaches the maximum transfer capability. The RPF enables transfers by increasing complex load in the sink area and injected real power generation in the source area in incremental steps until any violation incurred.

Mathematically, the calculation of TTC with TCSC or SVC is installed in the network can be defined as:

$$\text{Max } F(x) = O_{ATC} \quad (1)$$

Subject to:

$$E(f,g) = 0 \quad (2)$$

$$P_{Gi}^{\min} \leq P_{Gi} \leq P_{Gi}^{\max} \quad (3)$$

$$Q_{Gi}^{\min} \leq Q_{Gi} \leq Q_{Gi}^{\max} \quad (4)$$

$$V_i^{\min} \leq V_i \leq V_i^{\max} \quad (5)$$

$$S_j \leq S_j^{\max} \quad (6)$$

$$X_{TCSC}^{\min} \leq X_i \leq X_{TCSC}^{\max} \quad (7)$$

$$Q_{SVC}^{\min} \leq Q_{SVC} \leq Q_{SVC}^{\max} \quad (8)$$

Where,

O_{ATC} : ATC maximized function

$E(f,g)$: conventional power flow equation

P_{Gi}, Q_{Gi} : real and reactive power generation at bus i

f : the variables of FACTS devices

g : operating state of the power system

V_i^{\min}, V_i^{\max} : lower and upper limit of voltage magnitude at bus i

S_i^{\min}, S_i^{\max} : thermal limit of line i

$Q_{SVC}^{\min}, Q_{SVC}^{\max}$: reactive power limit

$X_{TCSC}^{\min}, X_{TCSC}^{\max}$: TCSC line reactance limit

For calculating TTC and ATC, the injected P_{Gi} at source area, and P_{Di} and Q_{Di} at sink area are increased in function of λ in which;

$$P_{Gi} = P_{Gi}^0 (1 + \lambda K_{Gi}) \quad (9)$$

$$P_{Di} = P_{Di}^0 (1 + \lambda K_{Di}) \quad (10)$$

$$Q_{Di} = Q_{Di}^0 (1 + \lambda K_{Di}) \quad (11)$$

Where $P_{Gi}^0, P_{Di}^0, Q_{Di}^0$ are the base case injection at bus i and K_{Gi}, K_{Di} are the constant used to specify the rate of changes in load as λ varies. In order to maintain a zero balance, the incremental power losses resulting from increases in transfer power are allocated by a given formula. At PV buses, the reactive power is maintain at the base case value. However, in sink area, the reactive power demand (Q_{Di}) is incremented accordingly to real power in order to keep a constant value of power factor.

The rate of λ change from $\lambda=0$ corresponds to no transfer (base case) to $\lambda=\lambda_{max}$ corresponds to the largest value of transfer power that causes no limit violations. $P_{Di}(\lambda_{max})$ is the

sum of load in sink area when $\lambda=\lambda_{\max}$ while P_{Di}^0 refers to the sum of load when $\lambda=0$. Therefore the sum of real power loads in sink area at the maximum power transaction in (normal or contingency case) represents the TTC value.

$$TTC = \sum_{i=1}^{ND_SNK} P_{Di}(\lambda_{\max}) - \sum_{i=1}^{ND_SNK} P_{Di}^0 \quad (12)$$

V. PROPOSED METHODOLOGY

A. Overview of the Bees Algorithm

Bees Algorithm is a novel optimization method developed by D.T.Pham in 2006 [18,19]. It is a kind of Swarm-based optimisation algorithms (SOAs) that mimic nature's methods to drive the search towards the optimal solution. This algorithm is inspired by honey bees' foraging behavior. In nature, bees are well known as social insects with well organized colonies. Their behaviors such as foraging, mating and nest site location have been used by researchers to solve many difficult combinatorial optimization and functional optimization problems. The Bees Algorithm has proved to give a more robust performance than other intelligent optimization methods for a range of complex problems.

B. Natural World of Bees

A colony of honey bees can fly on itself in multiple directions simultaneously to exploit a large number of food sources. In principle, flower patches with plentiful amounts of nectar or pollen that can be collected with less effort should be visited by more bees, whereas patches with less nectar or pollen should receive fewer bees [18].

In a colony, the foraging process starts by sending out scout bees to search for potential flower patches. The scout bees move from one patch to another randomly. During the harvesting season, a colony continues its exploration, keeping a percentage of the population as scout bees [18]. Those scout bees that found a patch deposit their nectar or pollen when they return to the hive and go to the "dance floor" to perform a dance called as the "waggle dance" [19].

This dance contains three pieces of information regarding a flower patch: its distance from the hive, the direction in which it will be found, and its quality rating (or fitness) [18]. This dance is necessary for colony communication, and the information helps the colony to send its bees to flower patches precisely, without using guides or maps.

The information provided from the dance enables the colony to evaluate the relative merit of different patches according to both the quality of the food they provide and the amount of energy needed to harvest it.

The dancer (scout bees) goes back to the flower patch with follower bees that were waiting inside the hive, after the waggle dance. More follower bees are sent to more promising patches. This allows the colony to gather food in fast and efficiently. The bees monitor its food level during harvesting from a patch to decide upon the next waggle dance when they return to the hive. More bees will be recruited to that source if the patch is still good enough as a food source. This information will be advertised in the waggle dance.

C. Description of Bees Algorithm

This section summarizes the main steps in BA to optimally allocate the FACTS devices to enhance ATC. The flowchart of the algorithm is shown in its simplest form in Figure 2. This flowchart represents the foraging behavior of honey bee for food.

This algorithm requires a number of parameters to be set, namely, number of scout bees (n), number of sites selected for neighbourhood search (out of n visited sites) (m), number of top-rated (elite) sites among m selected sites (e), number of bees recruited for the best e sites (nep), number of bees recruited for the other ($m-e$) selected sites (nsp), and the stopping criterion.

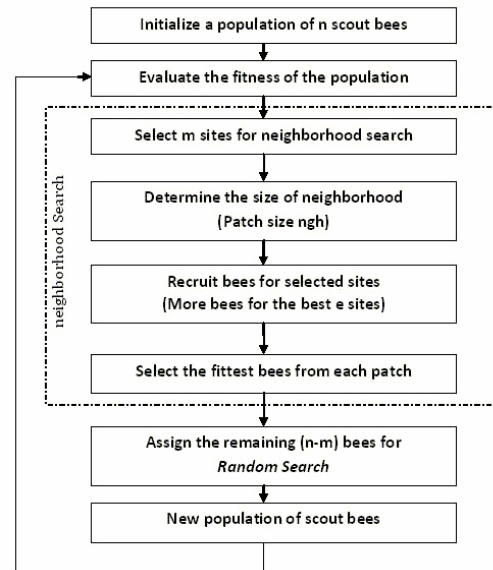

Fig. 2: Flowchart of Bees Algorithm

Step 1: The algorithm starts with an initial population of n scout bees. The initial population is generated from the following parameters;

n_{FACTS} : the number of FACTS devices to be simulated

n_{type} : FACTS types

$n_{Location}$: the possible location for FACTS devices

$n_{individual}$: the number of individual in a population.

The number of individual in a population is calculated using the following equations, where:

$$n_{individual} = 3 \times n_{FACTS} \times n_{Location}$$

Step 2: the fitness computation process is carried out for each site visited by a bee by calculating the ATC.

Step 3: repeat (step 4-8) until stopping criteria is not met. Else terminate.

Step 4: bees that have the highest fitnesses are chosen as "selected bees" (m sites) and sites visited by them are chosen for neighbourhood search.

Step 5: It is required to determine the size of neighborhood search done by the bees in the "selected sites".

Step 6 and 7: the algorithm conducts searches around the selected sites based on size determined in the step 4. More bees are assigned to search in the vicinity of the best e sites. Selection of the best sites can be made directly according to

the fitnesses related to them. In other word, the fitness values are used to determine the probability of the sites being selected. Searches in the neighbourhood of the best e sites which represent the most promising solutions are made more detailed by recruiting more bees for the best e sites than for the other selected sites [18]. Together with scouting, this differential recruitment is a key operation of the Bees Algorithm [18].

Step 8: The remaining bees ($n-m$) are sent for *random search* to find other potential sites.

Step 9: Randomly initialized a new population.

Step 10: Find the global best point.

D. Genetic Algorithm

A Genetic Algorithm (GA) is based on the mechanism of natural selection. It is a powerful numerical optimization algorithm to reach an approximate global maximum of a complex multivariable function over a wide search space. It always produces high quality solution because it is independent of the choice of initial configuration of population. Many researches [4-13] suggested that, the implementation of GA is quite easy and the computational is relatively simple. However, it can be noticed that GA has possibility to converge prematurely to a suboptimal solution.

In GA, the solution to a problem is called a chromosome. A chromosome is made up of a collection of genes which are simply the parameters to be optimized. A genetic algorithm creates an initial population (a collection of chromosomes), evaluates this population, then evolves the population through multiple generations using the genetic operators such as selection, crossover and mutation in the search for a good solution for the problem at hand.

The use of GA for FACTS allocation has been well explained in [4-13] and it is not repeated here. A Matpower 3.2[20] is used to solve the power flow calculation in order to calculate the ATC.

VI. CASE STUDIES AND RESULTS

The practice of the proposed method for optimal allocation of FACTS devices in a large system can be illustrated at beginning with a small (three bus) system shown in Figure 3.0. The ATC between Bus 1 (source) and Bus 2 (sink) is evaluated using RPF method. The system parameters and inequality constraints data are included in the appendix. Table I shows the GA and BA parameters used for simulation purposes. Table II show the results of ATC before and after the allocation of FACTS devices. Two types of FACTS devices being installed in the system to study the effectiveness of the devices in enhancing ATC. To verify the validity of the results of the proposed algorithm, a Genetic Algorithm method is prepared.

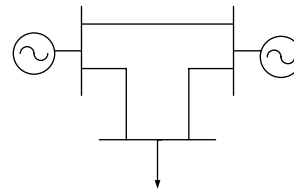

Fig. 3: Three bus system

TABLE I
PARAMETERS SET FOR GA AND BA FOR 3 BUS SYSTEM

GA	Population size	90
	Crossover rate, μ_c	0.6
	Mutation rate, μ_m	0.01
	Number of generation	100
BA	Number of scout bees, n	9
	Number of sites selected for neighbourhood search, m	6
	Number of best "elite" sites out of m selected sites, e	3
	Number of bees recruited for best e sites, n_{ep}	30
	Number of bees recruited for the other ($m-e$) selected sites, n_{sp}	15
	Number of iterations, R	25

A. Case1: ATC enhancement using TCSC

The results show that the proposed technique could allocate effectively the TCSC to enhance ATC. The ATC is increased from 211.98 MW to 233.98MW using BA, while using GA the ATC is enhanced to 231.96 MW with higher rated value of TCSC.

B. Case 2: ATC enhancement using SVC

The results shows the BA could allocate SVC much faster than GA for the nearly same results. BA converges in 25 iterations while GA takes 100 generation to converge.

It can be seen from the Table II, the Bees Algorithm was able to find solutions close to the optimum and performed slightly better than the GA. The results also show that SVC could enhance ATC much higher than TCSC. The ATC is increased from 211.98 to 231.96 using GA, while BA could search better value which is 233.98MW for the same location. From both of the cases, clearly shows that BA could reach the nearly same results as GA with approximately 4 times faster than GA. GA takes 100 generation to converges for the optimum solution while BA only takes 25 iteration to converge. Therefore, BA could reach the optimum solution in a very reasonable time and faster than GA.

To illustrate the applicability of the proposed method to allocate the FACTS devices in large scale system, a modified IEEE30 bus system is used. Figure 4.0 shows the sample test system. Bus and line data can be found in [21]. The system is divided into three areas with two generators in each area. The limits of FACTS devices are the same as for the previous case. Again, to validate the results from the proposed method, a GA is used.

TABLE II
RESULTS FOR SAMPLE 3 BUS SYSTEM

ATC without FACTS		Allocation Technique	ATC with FACTS Devices				
ATC (MW)	Limit Condition		Facts Type	Size (rated value)	Location	ATC (MW)	Limit Condition
211.98	Line 1-2	GA	TCSC	-0.664% X_{line}	Line 2-3	231.96	Line 2-3
			SVC	99.98MVar	Line 2-3	262.23	Line 1-2
		BA	TCSC	-0.727% X_{line}	Line 2-3	233.98	Line 2-3
			SVC	99.99MVar	Line 2-3	262.75	Line 1-2

TABLE III
RESULTS FOR IEEE 30BUS SYSTEM

Transfer		ATC without FACTS		Allocation Technique	ATC with FACTS Devices				
From area	To area	ATC (MW)	Limit Condition		Facts Type	Size (rated value)	Location	ATC (MW)	Limit Condition
1	2	50.56	PG ₁	GA	SVC	35.74MVAR	LINE 12-15	51.31	PG ₁
					SVC	59.74MVAR	LINE 9-10		
1	3	47.57	PG ₂₂	GA	SVC	29.68MVAR	LINE 8-28	50.24	PG ₁
					SVC	34.98MVAR	LINE 10-22		
2	1	8.07	PG ₂₃	GA	TCSC	-50.29% X_{line}	LINE 6-9	8.65	PG ₂₃
					SVC	38.3MVAR	LINE 8-28		
2	3	7.96	PG ₂₃	GA	TCSC	-47.10% X_{line}	LINE 9-10	8.49	PG ₂₃
					SVC	30.84MVAR	LINE 8-28		
3	1	24.78	PG ₂₇	GA	TCSC	-44.99% X_{line}	LINE 28-27	25.93	PG ₂₇
					SVC	41.82MVAR	LINE 8-28		
3	2	24.31	PG ₂₇	GA	TCSC	-53.67% X_{line}	LINE 27-28	25.59	PG ₂₇
					SVC	44.94MVAR	LINE 8-28		
3	2	24.31	PG ₂₇	BA	TCSC	-53.94% X_{line}	LINE 27-28	25.60	PG ₂₇
					SVC	43.86MVAR	LINE 8-28		

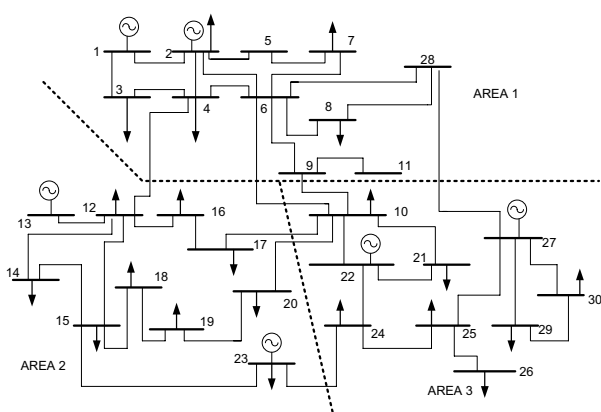

Fig. 4: Diagram of IEEE30 bus system

Two FACTS devices, TCSC and SVC are installed simultaneously in the system in order to enhance ATC. The proposed algorithm and GA could allocate the devices in certain combination of types, rated value and location. The results of the simulation are shown in Table II. Six cases are studied where the power is transferred from 1 to 2, 1 to 3, 2 to 1, 2 to 3, 3 to 1 and 3 to 2.

Using the RPF method without FACTS devices, the ATC to transfer the power from Area 1 to area 2 is 50.56MW and the limiting condition as expected is the generation upper limit at bus 1, PG1, if further transfers take place. When FACT Devices are installed using GA, the ATC to transfer power from Area 1 to Area 2 is increased 51.31MW and the limiting condition is the upper limit of the same generator, PG1. Using GA, two SVCs need to be placed at line 12-15 with 35.74MVAR and at line 9 to 10 with 59.74MVAR respectively. However, using BA, the ATC is increased to 51.33MW. The combination changes to one TCSC with rated

value of $-0.674\% X_{line}$ at location 6 to 9 and one SVC with size of 74.24MVAR at location 10 to 20.

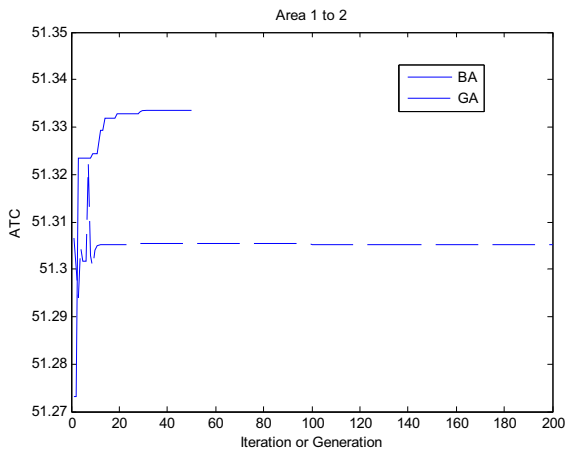

Fig. 5 : The convergences characteristics of the fitness of the BA and GA

It clearly shown that BA could effectively allocate the devices as GA does. Moreover BA could reach the optimum solution 4 times faster than GA for nearly the same results. For all of the cases, BA could find better location to install the devices to enhance ATC slightly better than GA. Figure 5 shows the comparison of rapid convergences characteristics of the proposed method and GA. For other transfer between different control areas, with and without FACTS devices, test results indicate that optimally placed FACTS devices can significantly enhance ATC of the system as shown in Table II.

VII. CONCLUSION

This paper has presented a new optimization algorithm to optimally allocate FACTS devices to enhance ATC. The simulation results tremendously prove that the proposed algorithm has remarkable robustness, in maximizing the ATC. Furthermore, the result also shows the effectiveness of the new approach in simultaneously optimized the FACTS location, rated values and FACTS types. It is a practical method for the allocation of FACTS devices in large power system.

The Bees algorithm converged to the maximum without becoming trapped at local optima. The algorithm generally outperformed the GA techniques that were compared with it in terms of speed of optimization and accuracy of the results obtained. The main advantage of BA is that it does not require external parameters such as cross over rate and mutation rate etc, as in case of genetic algorithms these are hard to determine in prior. The other advantage is that the global search ability in the algorithm is implemented by introducing neighborhood source production mechanism which is a similar to mutation process.

However, one of the drawbacks of the algorithm is the number of tunable parameters used. Nevertheless, it is possible to set the parameter values by conducting a small number of trials.

As far as the authors are concerned, this is the first application of bees algorithm in power system application regarding FACTS devices. Ideas presented in this paper can be applied to many other power system problems also. In future the authors would like to report further related studies by including the generation and FACTS operational costin the computation of ATC.

APPENDIX

APPENDIX I

PARAMETERS SET FOR GA AND BA FOR IEEE30 BUS SYSTEM

GA	Population size	820
	Crossover rate, μ_c	0.6
	Mutation rate, μ_m	0.01
	Number of generation	200
BA	Number of scout bees, n	246
	Number of sites selected for neighbourhood search, m	164
	Number of best "elite" sites out of m selected sites, e	82
	Number of bees recruited for best e sites, nep	30
	Number of bees recruited for the other ($m-e$) selected sites, nsp	15
	Number of iterations, R	50

ACKNOWLEDGMENT

The authors would like to thank Universiti Teknologi Malaysia for the financial support for the research. They are also grateful for the Dean of Faculty of Electrical Engineering for his support given to the present project .

REFERENCES

- [1] G. D. Galiana et al, "Assessment and control of the impact of FACTS devices on power system performance " *IEEE Trans on Power System*, Vol. 11, No 4, pp. 1931-1936, Nov. 1996.
- [2] K. S. Verma, S. N. Singh, H. O. Gupta, "Facts Devices Location for Enhancement of TTC", *Power Engineering Society Winter Meeting, IEEE*, Volume 2 , pp 522 – 527, 28 Jan.-1 Feb. 2001
- [3] S.N.Singh et al, "Optimal location of FACTS devices for congestion management", *Electric Pow.Syst. Research*.58(2001),pp71-79.Summary Plus| Full text + Links| PDF(118K)|View Record in Scopus| cited by in Scopus(27)
- [4] El Metwally, M.M.; El Emary, A.A.; El Bendary, F.M.; Mosaad, M.I., "Optimal allocation of FACTS devices in power system using genetic algorithms", *Power System Conference, 2008. MEPCON 2008. 12th International Middle-East*, 12-15 March 2008 Page(s):1 – 4
- [5] Baghaee, H.R.; Jannati, M.; Vahidi, B.; Hosseini, S.H.; Jazebi, S., "Optimal Multi-type FACTS Allocation Using Genetic Algorithm to Improve Power System Security", *Power System Conference, 2008. MEPCON 2008. 12th International Middle-East 12-15 March 2008* Page(s):162 – 166
- [6] W.Feng, G.Shrestha, Allocation of TCSC devices to Optimize Total Transmission Capacity in A Competitive Power Market, *In Proceedings of 2001 Winter Meeting of The IEEE Power Engineering Society*, 28 Jan-1 Feb.2001. Columbus.OH.USA:IEEE
- [7] S.Gerbex, R.Cherkaoui and A.J. Germond, "Optimal Location of Multiple Type of Facts Devices in a Power System by Means of Genetic Algorithms", *IEEE Trans. Power Sys.*, 2001 Vol 16, pages537-544.
- [8] S.Gerbex, R.Cherkaoui and A.J. Germond, "Optimal Location of FACTS Devices to Enhance Power System Security", *IEEE Bologna Power Tech Conference*, June 23-26, 2003, Bologna Italy.
- [9] S.R.Najafi, M.Abedi, S.H.Hosseini, " A Novel Approach to Optimal Allocation of SVC using Genetic Algorithms and Continuation Power Flow", *International Power and Energy Conference PECon 2006*, Nov. 28-29, 2006, Putrajaya, Malaysia

- [10] Ippolito, Lucio, La Cortiglia, Antonio; Petrocelli, Michele, "Optimal allocation of FACTS devices by using multi-objective optimal power flow and genetic algorithms", *International Journal of Emerging Electric Power Systems*, v 7, n 2, 2006, p 1-19
- [11] D. Radu, Y. Besanger, "A multi-objective genetic algorithm approach to optimal allocation of multi-type FACTS devices for power systems security", *2006 IEEE Power Engineering Society General Meeting, PES, 2006 IEEE Power Engineering Society General Meeting, PES*, 2006, p 1709202
- [12] H.I.Shaheen, G.I.Rashed,S.J. Cheng, "Optimal location and parameters setting of unified power flow controller based on evolutionary optimization techniques", *2007 IEEE Power Engineering Society General Meeting, PES, 2007 IEEE Power Engineering Society General Meeting, PES*, 2007, p 4275463
- [13] L.J. Cai, I. Erlich, "Optimal Choice and Allocation of FACTS devices using Genetic Algorithms," *Proc. on Twelfth Intelligent Systems Application to Power Systems Conference*, pp. 1-6, 2003.
- [14] W. Ongskul, P. Jirapong, "Optimal allocation of FACTS devices to enhance total transfer capability using evolutionary programming," *IEEE International Symposium on Circuits and Systems*, Vol..5, pp.4175-4178, 23-26 May, 2005
- [15] M.Santiago-Luna, J.R.Cedeno-Maldonado, "Optimal placement of FACTS controller in power system via Evolution Strategies", *IEEE PES Transmission and Distribution Conference and Exposition Latin America, Venezuela, 2006*.
- [16] M. Saravanan, etal, "Application of PSO technique for optimal location of FACTS devices considering system loadability and cost of installation," *Power Engineering Conference*, Vol. 2 pp.716 – 721, 29 Nov.2 Dec.2005.
- [17] E.Nasr Azadani, S.H.Hosseinian, M.Janati, P.Hasanor, "Optimal placement of Multiple STATCOM", *Power System Conference, 2008. MEPCON 2008. 12th International Middle-East*, 12-15 March 2008 Page(s):523-528
- [18] D T Pham, A Ghanbarzadeh, E Koc, S Otri, S Rahim and M Zaidi (2006) The Bees Algorithm, A Novel Tool for Complex Optimisation problems. *Proc 2nd Int Virtual Conf on Intelligent Production Machines and Systems (IPROMS 2006)* Oxford:Elsevier 454-459
- [19] D T Pham, E Koc, J Y Lee and J Phruksanat (2007) Using the Bees Algorithm to schedule jobs.
- [20] R.D. Zimmermann and D.Gan, "Matpower a Matlab® power system simulation package, User's Manual",Version 3.2, 2004.
- [21] http://www.eng.nsf.gov/iucr/directory/iucr_ee.htm