

One Typical Jacket Platform's Reactions in Front of Sea Water Level Variations

M. A. Lotfollahi Yaghin, R. Rezaei

Abstract—Demanding structural safety under various loading conditions, has focused attention on their variation and structural elements behavior due to these variations. Jacket structures are designed for a specific water level (LAT). One of the important issues about these kinds of structures is the water level rise. For example, the level of water in the Caspian Sea has risen by 2.5m in the last fifteen years and is continuing to rise. In this paper, the structural behavior of one typical shallow or medium water jacket platform (a four-leg steel jacket platform in 55m water depth) under water level rise has been studied. The time history of Von Mises stress and nodal displacement has chosen for evaluating structural behavior. The results show that dependent on previous water depth and structural elements position; different structural elements have different behavior due to water level rise.

Keywords—Jacket offshore platform, Time- history, Von Mises, Water level rise, Utilization Ratio.

I. INTRODUCTION

THE principal criterion in the design of an offshore structure, as in the case of any other structure, is to ensure that the structure safely performs its intended functions during the design service life. A design based on rational approach guarantees that the structure performs its intended functions for the whole of design life. In certain situations, the structural design and assessment practices are based on component level whereas in certain other situations, a global level approach is necessitated. The safety requirements of offshore structure are generally assessed at component levels, following design codes. In general terms, if the safety requirements at component level are not satisfied, it implies that the structure needs strengthening in order to meet the additional demands. However, taking into account the design procedures and the structural redundancy available in following standard design practices, it can be taken that in spite of failure of some of components; the structure can undergo member load redistribution and thus avoid failure.

Maintenance of structural integrity of critical components is an important issue in many fields of engineering.

The objective is to ensure economical and safe operation of the facility that employs the structure. Offshore structures are intended to perform in hostile/aggressive marine environment. An essential step to maintain the structural integrity is to make

an initial prediction about the safety of the structure over its life and to plan inspections based on it [1].

The most commonly used offshore platforms in the Gulf of Mexico, Nigeria, California shorelines and the Persian Gulf are template type platforms made of steel, and used for oil/gas exploration and production [2], [3]. These offshore structures must function safely for design lifetimes of twenty-five years or more and are subject to very harsh marine environments. Some important design considerations are peak loads created by hurricane wind and waves, fatigue loads generated by waves over the platform lifetime and the motion of the platform.

The Caspian Sea is the largest single lake in the world. It is a remnant of an extremely large sea (Tethys) which in previous times covered the total area of Iran, Turkey, south-eastern Russia and the Mediterranean Sea. The level of water in the Caspian Sea has risen by 2.5m in the last fifteen years and is continuing to rise. Therefore, offshore structures, which have been installed in this area, have to be evaluated in front of water level rise, because one of the parameters in design of offshore structures is water depth value at installation place. Obviously, any variation in water depth will have significant effect on structural serviceability.

II. STRUCTURAL LOADING

A. Wave Loading

In-service loading of Jackets is mainly due to wave and/or wind action; these are dynamic in nature. More generally, dynamic loading is all loading that has an appreciable variation with time. For many design purposes, it is adequate to consider variable loads in terms of an equivalent static load. The validity of such an approach depends on two main factors. The first factor is the form of the structure and the second is the nature of the load.

The design wave approach is based on this methodology and is applied by defining a wave, of large height and period range, whose probability of occurrence is such that it represents the maximum wave that the structure will encounter within the return period. This approach is only realistic from the viewpoint of designing against static structural failure due to a large wave, and does not permit fatigue damage to be considered within the design. The design wave approach is not satisfactory for smaller waves with excitation frequencies that can lead to structural resonance.

A number of wave theories such as Airy, Stokes, Stream Function, Cnoidal and Solitary Wave Theory, enable a suitable wave theory to be applied for the estimation of wave load. The most suitable wave theory is dependent upon wave

M. A. Lotfollahi- Yaghin is with University of Tabriz, Tabriz, Iran (Phone: 0098-411-3341241; fax: 0098-411-3344287; e-mail: a_lotfollahi@yahoo.com).

R. Rezaei is post graduated from University of Tabriz, Tabriz, Iran (e-mail: Ro.Rezaei@gmail.com).

height, the wave period and the water depth. The most applicable wave theory may be determined from Fig. 1, which is taken from API-RP2A (American Petroleum Institute, Recommended Practice for Planning, Designing and Constructing Fixed Offshore Platforms).

The appropriate wave theory can be determined by water depth, wavelength and wave period. Stoke wave theories are valid for $(d/L > 0.039)$, and Cnoidal or Solitary wave theories for shallow sea of $(d/L > 0.04)$. After selecting the approximate wave theory, the wave force can be calculated by the Morrison Equation (1).

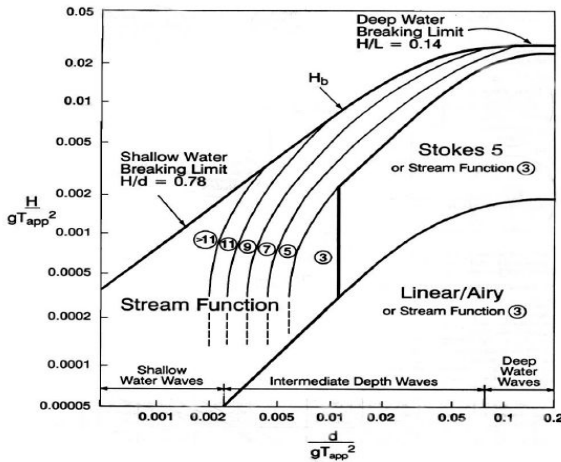

Fig. 1 Applicability of wave theories

To calculate wave load we assume the water to be on average 55m deep, significant wave height and wave period respectively of $H_s = 2.5m$ and $T_z = 6.5sec$.

Because the ratio of horizontal dimension (D) to wavelength (L) is smaller than 0.05, we can calculate the wave load with Morrison's Formula.

Wave load depends on the form of the structure (here jacket platform), the form of the current, Inertia force due to wave particle velocity, the roughness of the surface and Drag force depending on Reynold's number.

The wave force, dF, on a slender cylindrical element with diameter D and length ds is according to Morrison theory given by:

$$dF = \left\{ \rho \frac{\pi}{4} D^2 C_M a_n + \frac{1}{2} \rho C_D D v_n |v_n| \right\} ds \quad (1)$$

where ρ is density of water, C_M is the mass coefficient and C_D is the drag coefficient, a_n is water particle acceleration and v_n is the water particle velocity including any current (wave velocity and current are added vectorally). The acceleration and velocity are evaluated normal to the pipe longitudinal axis. The drag term is quadratic. The sign term implies that the force changes direction when the velocity changes direction.

The total wave force has been obtained by integrating (1) along the member axis.

A. Current Loading

Because the actual current is composed of the various sums of currents coming from multi-directions, it is common to measure the current speeds at several depths of the region [4].

In this study, one hypothetic current, with a return period of one year, is used to modeling the current load. This current varies with depth. Table I shows the current variation with depth:

TABLE I
CURRENT PROFILE

Depth (%)	Current Velocity(m/s)
0	0.9
10	0.8
20	0.8
30	0.7
40	0.7
50	0.6
60	0.6
70	0.5
80	0.5
90	0.4
Sea bed	0.4

III. VON MISES STRESS

An elastic body that is subjected to a system of loads in 3 dimensions, a complex 3 dimensional system of stresses is developed (as you might imagine). That is, at any point within the body, there are stresses acting in different directions, and the direction and magnitude of stresses changes from point to point. The Von Mises criterion is a formula for calculating whether the stress combination at a given point will cause failure.

There are three "Principal Stresses" that can be calculated at any point, acting in the x, y, and z directions. (The x, y and z directions are the "principal axes" for the point and their orientation changes from point to point, but that is a technical issue.)

Von Mises found that, even though none of the principal stresses exceeds the yield stress of the material, it is possible for yielding to result from the combination of stresses. The Von Mises criterion is a formula for combining these 3 stresses into an equivalent stress, which is then compared to the yield stress of the material. The yield stress is a known property of the material, and is usually considered to be the failure stress.

The equivalent stress is often called the "Von Mises Stress" as a shorthand description. It is not really a stress, but a number that is used as an index. If the "Von Mises Stress" exceeds the yield stress, then the material is considered to be at the failure condition.

The von Mises theory is simply one of several failure theories used to determine the applied stress in a member. It combines principle stresses, from Mohr's Circle (bending & torsion), into an equivalent applied stress which is compared to the allowable stress of the material. In some sources, von Mises is also called the Distortion-Energy Theory. In this study von Mises stress is used to evaluate structural members'

serviceability due to change in loading condition due to water level rise. For this purpose after getting the time history of von Mises stress, its RMS value was calculated for different depth and various structural elements.

IV. STRUCTURAL ELEMENTS UTILIZATION RATIO

The objective of structural design is to ensure that the stresses resulting from maximum loading on a structure are adequately below the specific limit. This condition requires the use of the ultimate limit state in an analysis. The ultimate limit state refers to a failure due to the loss of capacity caused by the maximum environmental loading. Typically, two types of ultimate limit states may be utilized for jacket platforms. Ultimate limit state is a good method to assessing serviceability of structural members. Although ultimate limit state or utilization factor has been used for reliability analysis, it can be used for evaluating structural behavior, because it uses combination of different types of stresses in structural elements.

The first ultimate limit state is based on a global response of the platform and the global failure caused by the overturning moment or shear force. This type of ultimate limit state has been applied in the research projects of Karunakaran [5], Jensen et al. [6] and Van de Graaf et al.[7]. In this method, it is not possible to investigate the failure of an individual element or joint due to the extreme environmental load. However, failure of an individual element or joint may reduce the resistance of the structure significantly.

The second ultimate limit state function refers to the loss of capacity of a structural element or joint in accordance with the formulation specified in the codes such as API RP 2A-WSD [8], API RP 2A- LRFD [9] or NORSOK [10]. This approach has already been applied for jacket platforms by Shetty [11] and Dalane [12], and for a jack-up platform by Daghigh [13].

In the present research study, the utilization ratio has been derived based on the second approach. Details have been presented in the following section. At first, the concept of a usage factor or a utilization ratio is discussed.

Failure is defined for each individual member of the structure by a failure function describing a limit state. A member fails if a limit state is reached. The limit state or failure function used for the truss members of the example jacket is the condition that the axial member force is equal to its elastic resistance. Failure of the system can be defined in terms of failures of its members [14]. The AISC formula given below was used for the capacity of compression members [15]:

$$F_a = \frac{[1 - \frac{(Kl/r)^2}{2C_c^2}]F_y}{5/3 + \frac{3(Kl/r)}{8C_c} - \frac{(Kl/r)^3}{8C_c^3}} \text{ for } Kl/r < C_c \quad (2)$$

$$F_a = \frac{12\pi^2 E}{23(Kl/r)^2} \text{ for } Kl/r \geq C_c \quad (3)$$

$$C_c = (\frac{2\pi^2 E}{F_y})^{1/2} \quad (4)$$

$$F_b = 0.75F_y \text{ for } \frac{D}{t} \leq \frac{10340}{F_y} \quad (5)$$

$$F_b = [0.84 - 1.74 \frac{F_y D}{Et}] F_y \text{ for } \frac{10340}{F_y} < \frac{D}{t} \leq \frac{20680}{F_y} \quad (6)$$

$$F_b = [0.72 - 0.58 \frac{F_y D}{Et}] F_y \text{ for } \frac{20680}{F_y} < \frac{D}{t} \leq 300 \quad (7)$$

E = Young's Modulus of elasticity, (MPa).

K = effective length factor, (Table II).

l = unbraced length, (m).

r = radius of gyration, (m).

F_a = design axial (compression or tension) stress (Pa).

F_b = design flexural stress (Pa).

D = pipe outside diameter (m).

t = pipe wall thickness (m).

F_y = Yield stress (Pa).

The ultimate limit state function is then introduced based on the design code for offshore structures. Several formulations are given in the design code to specify different types of losing capacity due to the interaction of several types of loading configurations. These formulations, which are also known as failure modes or criteria, are usually expressed as a normalized function of the stresses in the members. They should not exceed a specific value i.e. one. The value of this function is generally referred to as the "utilization ratio" or "usage factor", U, and a code failure occur if it exceeds this value. The axial stress in the structural elements is not always in the same stress state due to the cyclic action of wave loads and may change from compression into tension. Then for evaluating the behavior of structural elements, using utilization factor instead of axial stress or bending stress separately is a good opinion. An example of a utilization ratio for buckling of a tubular member in combination of compression and bending stresses is presented in API RP2A-WSD [8] as follows:

$$U_1 = \frac{f_a}{F_a} + \frac{C_m \sqrt{f_{bx}^2 + f_{by}^2}}{\left(1 - \frac{f_a}{F_e}\right) F_b} \quad (8)$$

$$U_2 = \frac{f_a}{0.6F_y} + \frac{\sqrt{f_{bx}^2 + f_{by}^2}}{F_b} \quad (9)$$

where f_a and f_{bx} and f_{by} are the axial compressive and maximum bending stresses in the elements and F_a , F_b and F_e are the nominal axial compressive, bending and Euler buckling strengths respectively and are given by API [8]. These parameters are dependent on diameters, lengths, thicknesses,

elastic section modules, module of elasticity, etc and can finally be related to a yielding stress. U_1 and U_2 are two different criteria to calculate stress combination value in various elements of jacket structure based on API.

V. STRUCTURAL MODELING

A. Assumptions

The structural model has been made as simple as could be justified. A model of the structure should include all principal members of the structure. These assumptions lead to a space model representation of the structure consisting of 56 elements and 28 nodes. The foundation is rigid. The structure was designed according to the API-RP2A-WSD guidelines using X-braces and diagonal braces. For studying water level variations' effects on structural elements' behavior absolutely, it is assumed that the clearance of the jacket's deck is high enough and after water level rise, the deck is safe like before.

In this study one jacket structure has been modeled using finite element model. For studying effects of water level variation on structural behavior, the water level changed and each model studied separately. All of the structural characteristics among these models are the same; just the water depth has changed. In this paper, three different models have been studied. Fig. 2 shows these three models and three different design water depths. For each model, the water level rise has been applied and structural reaction to the new condition has been evaluated separately. The principal aim of this study is to assess the effect of initial water depth on structural behavior after water level rise.

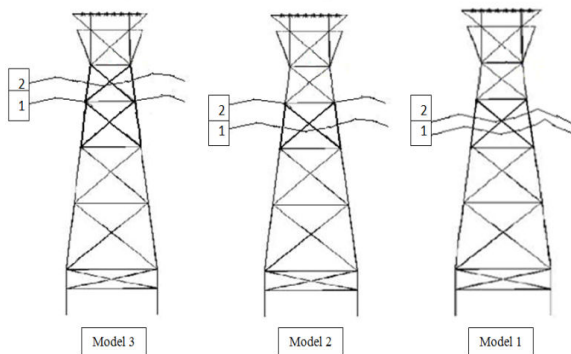

Fig. 2 Three different models used in this study

The API recommended k-factors used to design the structure are given in Table II. Based on testing experience, more realistic values of k's were recommended by engineers at Exxon for calculating the mean resistance of the jacket members.

Note that the k-factor used for X-braces implies that the compression members are fully supported with respect to buckling out of plane by the intersecting tension member[16].

Member type	Design k ,L
x-brace	0.9, L/2
k-brace	0.8, L
Diagonal brace	0.8, L
Leg	1.0, L
Horizontal leg to leg brace	0.7, L

B. Finite Element Model

In this paper, the finite element method (ANSYS) is used for modeling of the structure. The 4-leg steel jacket is numerically modeled with the fixed boundary condition at the sea bottom. Any analysis of offshore platforms must also include the equipment weights and a maximum deck live loading (distributed area loading), dead loads in addition to the environmental loads.

Element PIPE59 in the software ANSYS [17] is used to solve the problem. The element PIPE59 is similar to beam element but more powerful, with the function of buoyancy, waves and current loads calculation. Fig. 3 shows the mechanical model of element PIPE59[18]. The deck weight is modeled using concentrated mass elements MASS21. This is a point element having up to six degrees of freedom: translations in the nodal x, y, and z directions and rotations about the nodal x, y, and z axes. Characteristics of jacket structures are given in Table III. Fig. 4 shows the finite element model used for the time- history response prediction.

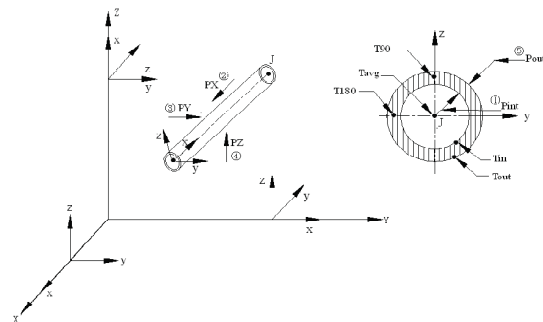

Fig. 3 Mechanical model of element PIPE59

TABLE III
MEMBERS DIMENSION OF JACKET STRUCTURE

member	Deck legs	Jacket legs	Horizontal and vertical braces	In plane horizontal braces
diameter(m)	D=1.6	D=1.6	D=1.5	D=1.2
thickness(m)	t=0.018	t=0.018	t=0.016	t=0.014

VI. RESULTS AND DISCUSSION

A. Assessment of Deck's Nodal-Displacement

In this study for evaluating the effects of sea water level variations on time history response, initially the deck displacement of jacket has been analyzed. Since all of the nodes, which are located at deck level, reveal the same behavior due to water level rise, one of these nodes is selected and the results of time history analysis are illustrated.

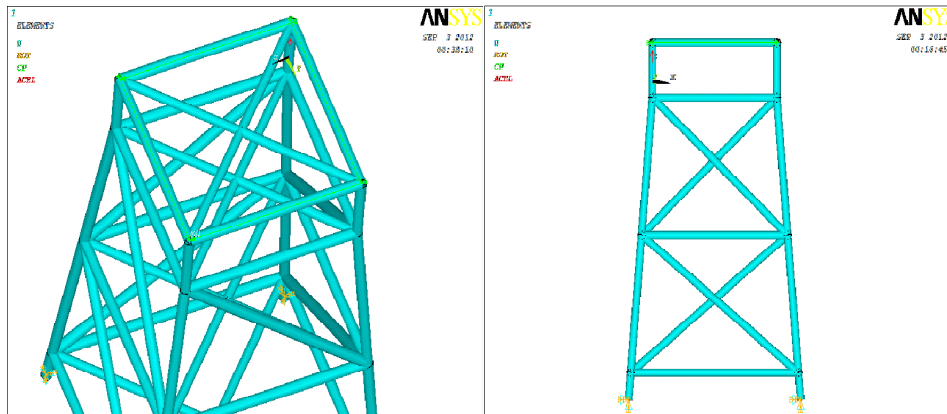

Fig. 4 Finite element model of jacket structure

According to Figs. 5 to 7, nodal displacements' time histories reveal a great deal of oscillation due to water level rise. These figures illustrate when the water level reaches structural joints, where the structural elements meet, there is time shifting among maxima and minima of time history responses for two different water depths. It may be because of hitting the elements and subsequently the joints at that location with the peaks of wave profile. When the water level is located on leg elements before and after water level rise, there is not any noticeable, time shifting or difference between time history responses for two situations. The effects of water level rise on displacement's time history response are more considerable for water level increasing from 55m to 57.5m. Although with increasing the water depth, the displacement's value decrease quantitatively, these kinds of oscillations can be dangerous at these joints since these joints are hot spots of the structure and transmit horizontal and inclined elements forces to the legs of the structure. According to these figures, the effects of water level rise on time history responses of displacement are more significant for z-direction. Fig. 8; illustrates these variations for one node at deck level in z-direction simultaneously. The difference among the time histories of displacements for different water depths is more obvious from this figure. As this figure shows, increasing the sea water level has considerable effects on deck displacement especially for structures with high operation water depth [19]. At first, it is obvious that with increase in operational water depth, deck displacement have decreased. For depth 55m, fluctuations are more than other depths and this is because of locating the water level on jacket horizontal level, where there is intersection between horizontal elements and jacket legs. This shows that these joints are hot spots and when water level reaches there, the structure will be in a critical situation and safety of structure should be evaluated. At this level, there is some phase delay in comparison with other depths. According to characteristics of incident wave for this structure, deck response is similar to incident wave, with same frequency, only the amplitude or phase of the response is different but this is not correct for depth 55m. At depth 55m there is some disturbs in the structural response and response fluctuations are more than other depths.

B. Evaluating Von- Mises Stress and Utilization Ratio of Jacket's Structural Elements

A Von-Mises failure criterion is adopted to investigate the time-history response of jacket structural elements due to water level rise. In order to study the effect of design water level on structural elements responses after water level rise, four models with different design water levels are made and Von-Mises stress is considered. These models have same structural characteristics but different water depths.

For studying the variations of Von-Mises stress in jacket members, we studied the time history of Von-Mises stress of whole members of jacket structure, including horizontal braces, X-braces and portal members.

It was expected that because of water level rise, the stress in structural elements would increase. But, the results show different behaviors. For further analysis, at first the RMS value (root mean square) of time histories of Von-Mises stress is calculated. Then, the RMS values of time history responses for the elements, which are located at the same level, are simultaneously represented in one graph, as Figs. 9 to 12 reveal. These figures include the RMS value of different elements at the same elevation in the jacket structure and their variation with water level rise.

According to Figs. 9 to 12, different elements have different behaviors due to water level rise. Some of structural elements experience increase in stress value and some others show decrease. However, there are some elements that strictly predicting their behaviors due to water level rise is difficult. These elements show increasing RMS values for some depths variations and decreasing for others. The investigation of the results show that depth variation from 55m to 57.5m is more critical because the responses' rate of changes are more higher and stress variation in this span is important. For this reason, this study has mostly focused on this span of water level variation and its effects are investigated.

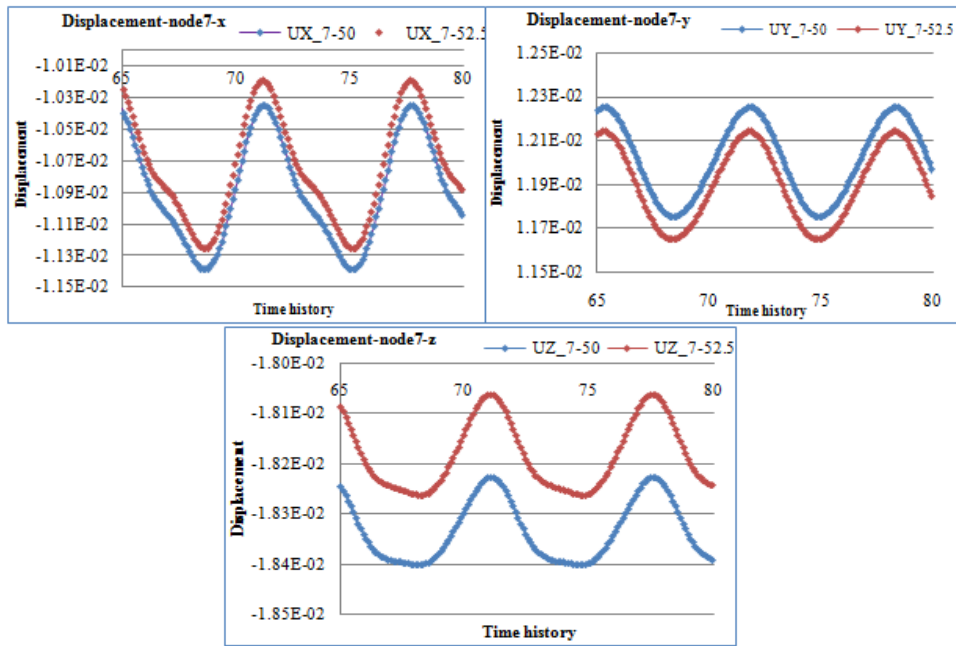

Fig. 5 Time history of nodal-displacement at the deck level for depth 50&52.5m (node No.7)

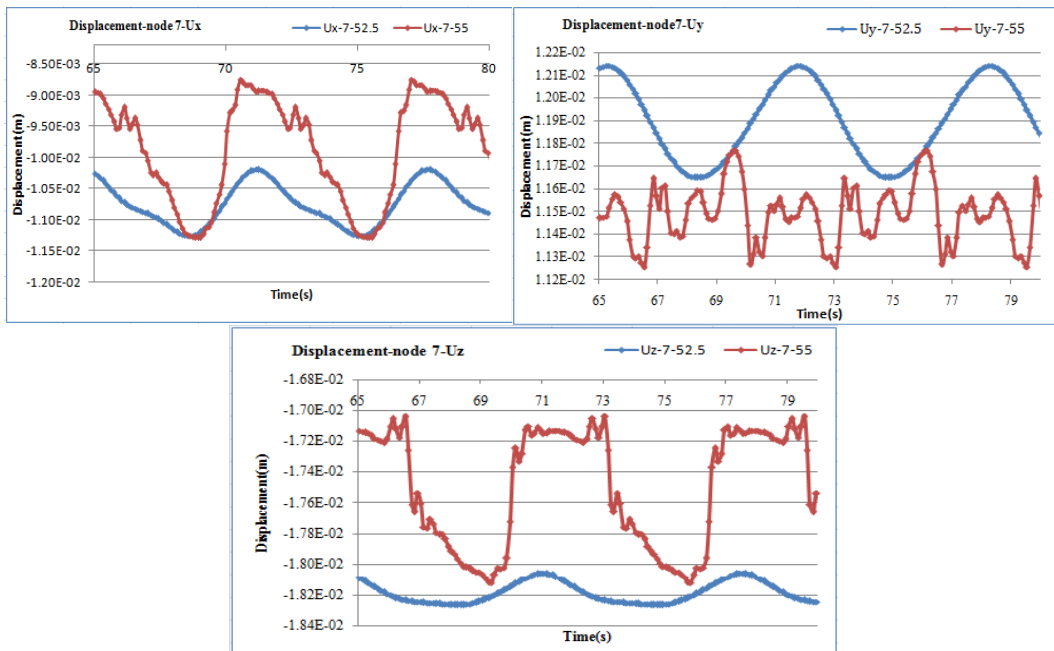

Fig. 6 Time history of nodal-displacement at the deck level for depth 52.5&55m (node No.7)

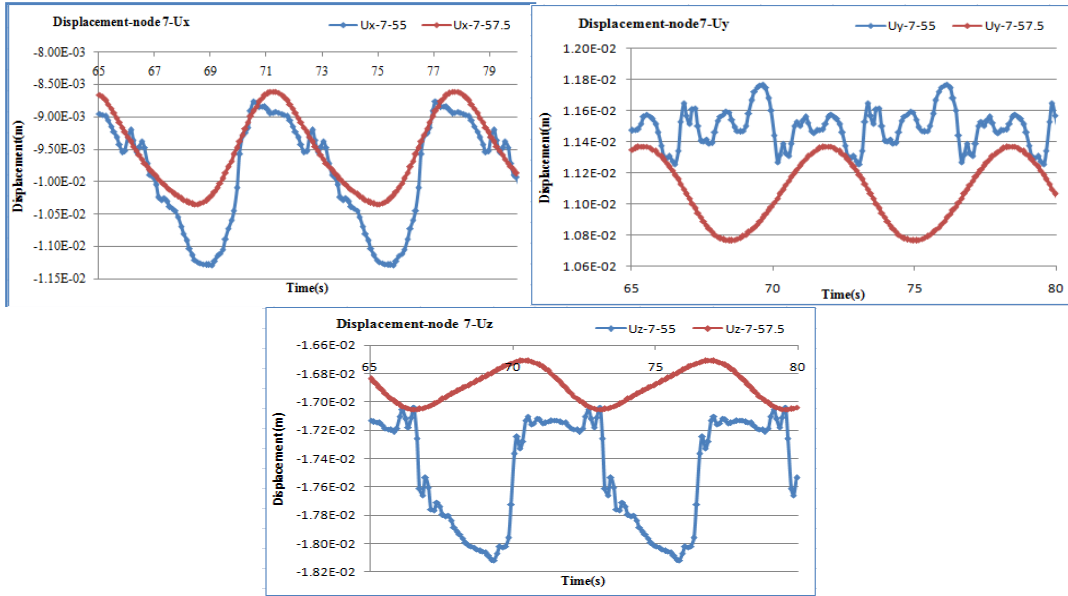

Fig. 7 Time history of nodal-displacement at the deck level for depth 55&57.5m (node No.7)

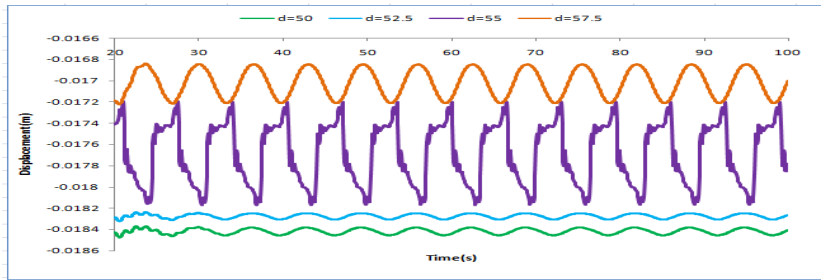

Fig. 8 Time history variation due to water level rise in nodal displacement for nodes located on deck level

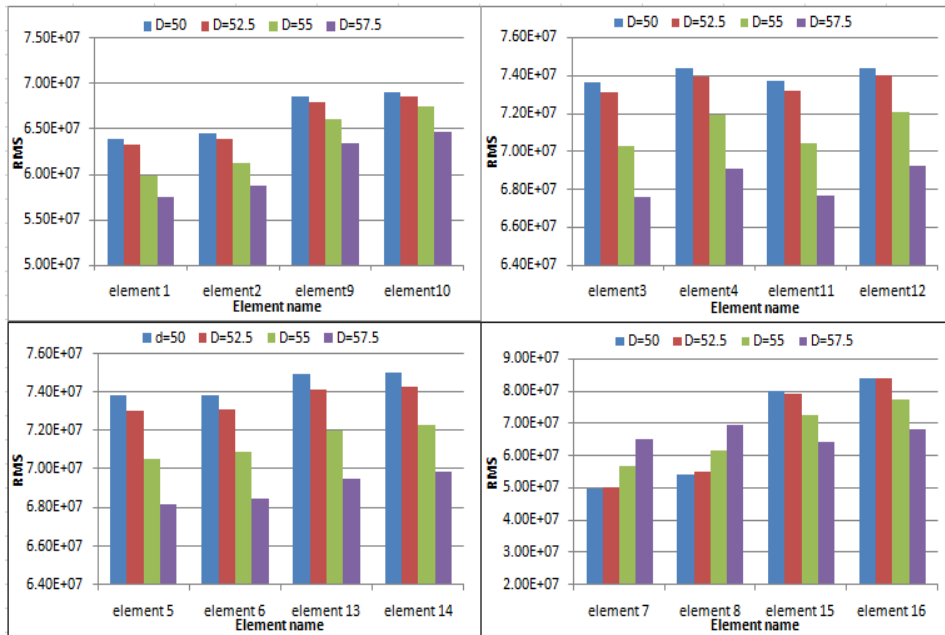

Fig. 9 The RMS value of time history of Von-Mises stress for legs

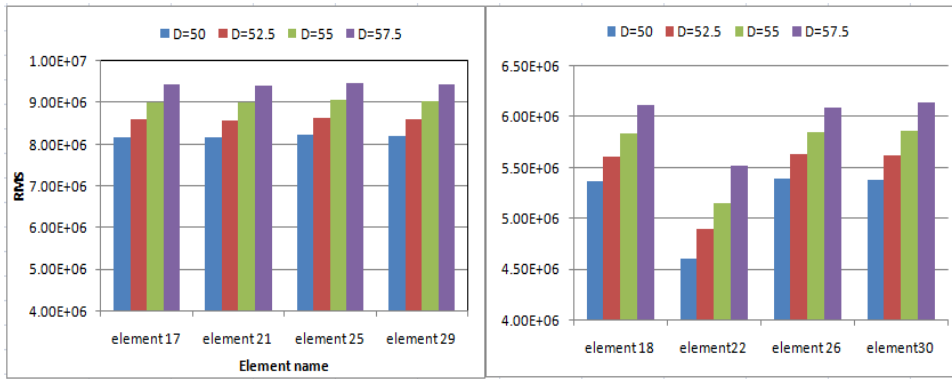

Fig. 10 The RMS value of stress for horizontal braces

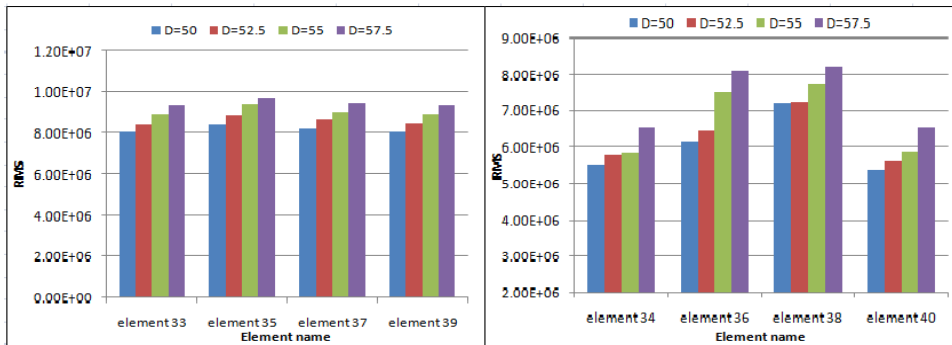

Fig. 11 The RMS value of Von-Mises stress for diagonal braces

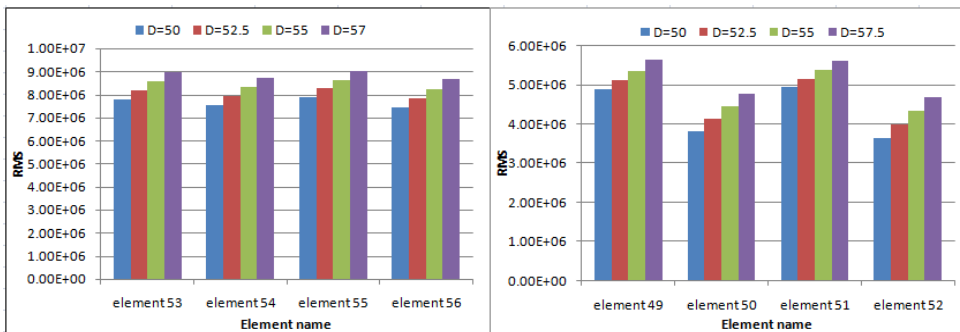

Fig. 12 The RMS value of Von-Mises stress for in-plane braces

In order to evaluating structural elements behaviors more precisely, incremental analysis is considered. In this part, water depth varies incrementally and at each depth increment, time histories of whole elements utilization ratios are evaluated. Figs. 13 to 16 illustrate the utilization ratios of structural elements for various water depths at node i and node j of the structural elements.

As these figures reveal, elements at different depths have different behaviors. It was expected that with water level rise the axial stress and bending stress and consequently the utilization ratios of structural elements would be increased. However, according to the results, the reactions of structural elements to water level rise are different, not only, for different elements at different locations, but also for one element at various water depths, these differences are obvious.

It means that for one element with water level rise, it is wrong to predict mere increase or mere decrease. The whole of structural elements have random behaviors in respect to sea water level rise. These figures show that for all of the structural elements, as water level reaches to around 56m, structural elements responses have strong fluctuations and it is difficult to identify their increase or decrease with respect to water level rise, and it is possible to see both of them at consecutive water level rises. By reaching the water depth to about 56m, the majority of elements will have the same behavior. All of them show linear decrease or increase in utilization ratios with respect to water level rise. For example, in plane braces after around 56m experience linear increase and this is the same for node i and node j of the elements. On

the other hand, for jacket legs, this variation is a slight linear decrease for node i and node j.

According to these results, for different structures there are different critical depths. For these depths, it is possible some of the structural elements experience stresses above what they

designed to tolerate, and this will be a disaster for principal structures like jacket structures. In order to reveal different elements behaviors due to water level rise, Figs. 17 and 18 show the utilization ratios variations for all of the structural elements at node I and j for different water depths.

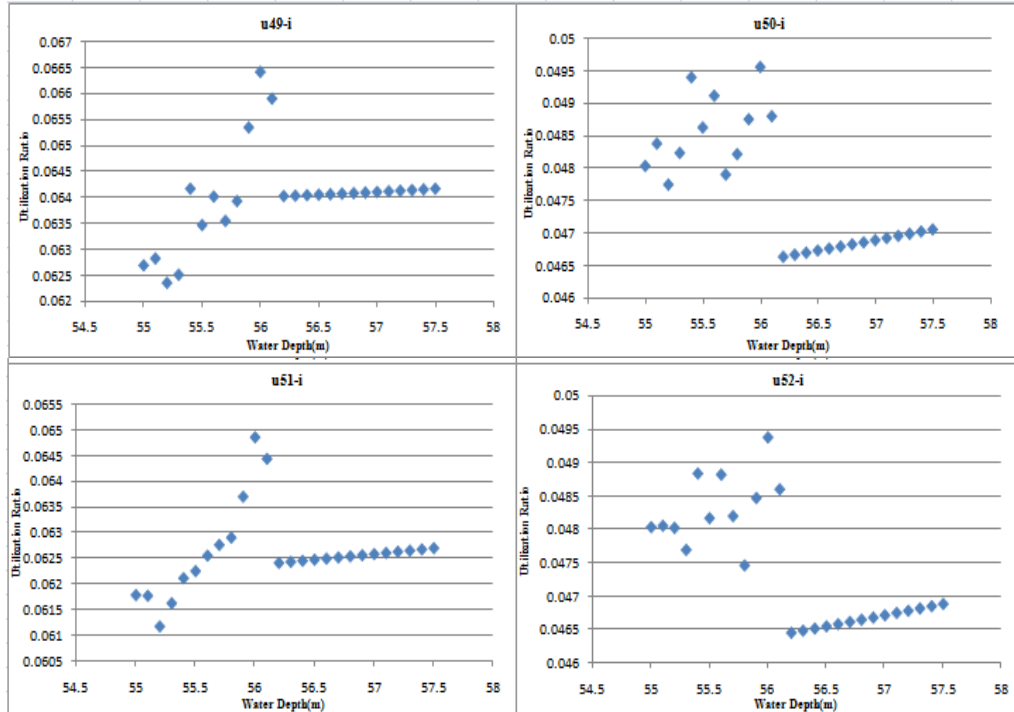

Fig. 13 The Ut-ratio of in plane braces at different levels (node-i)

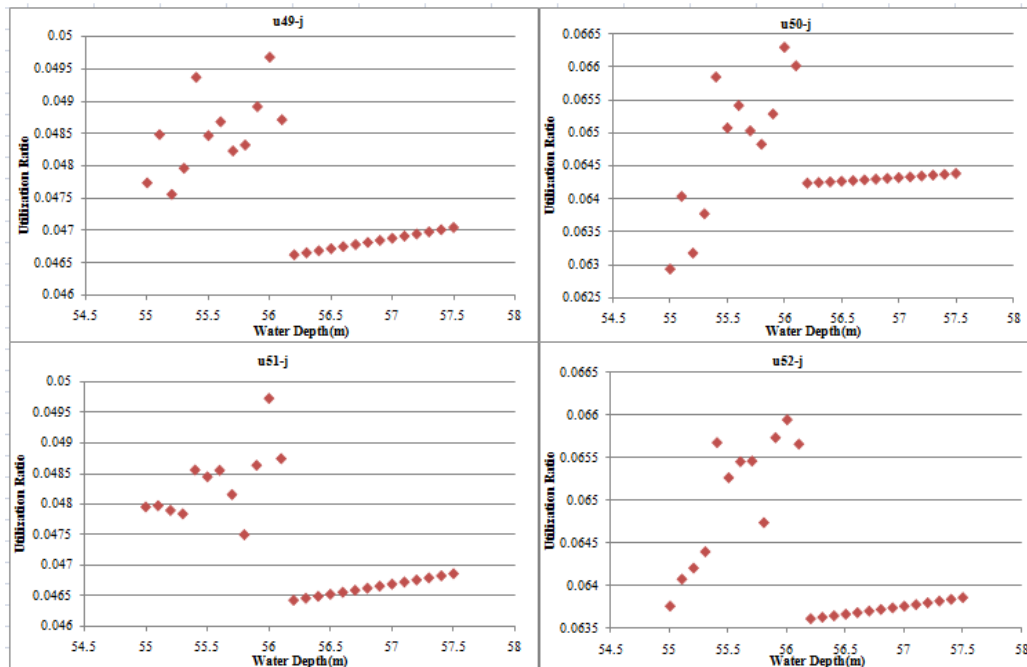

Fig. 14 The Ut-ratio of in plane braces at different levels (node-j)

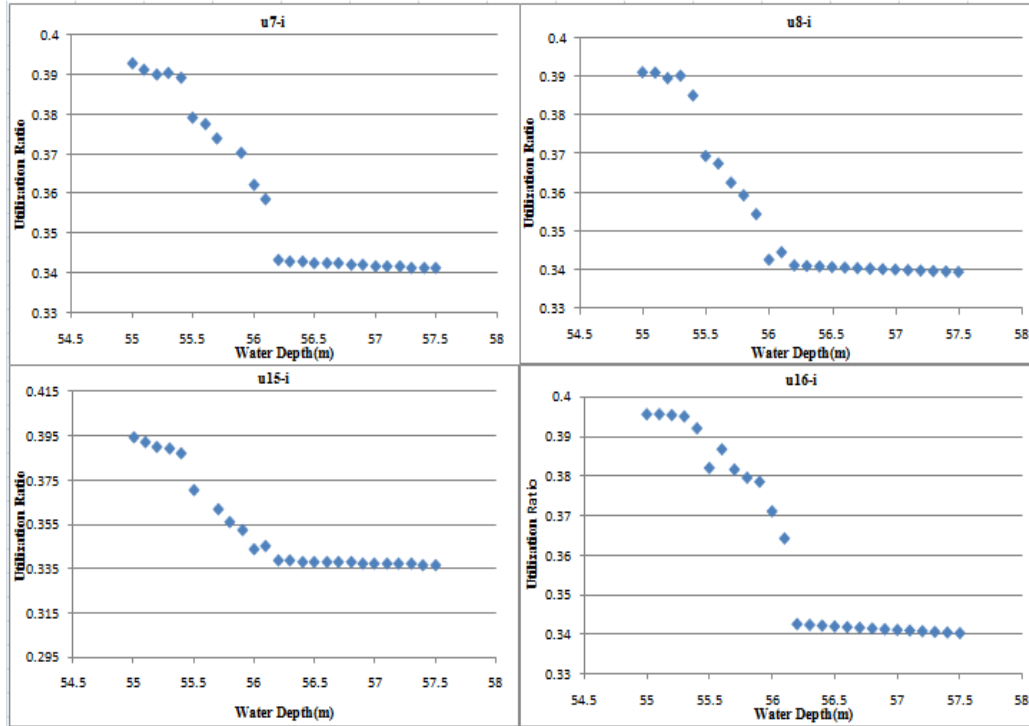

Fig. 15 The Ut-ratio of jacket legs at different levels (node-i)

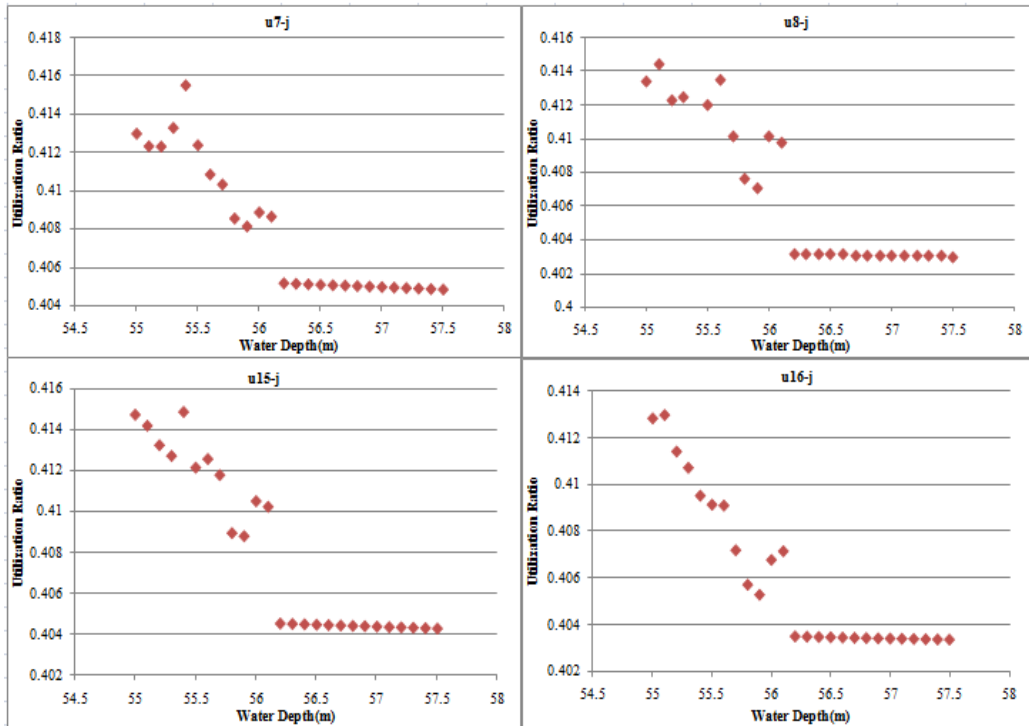

Fig. 16 The Ut-ratio of jacket legs at different levels (node-j)

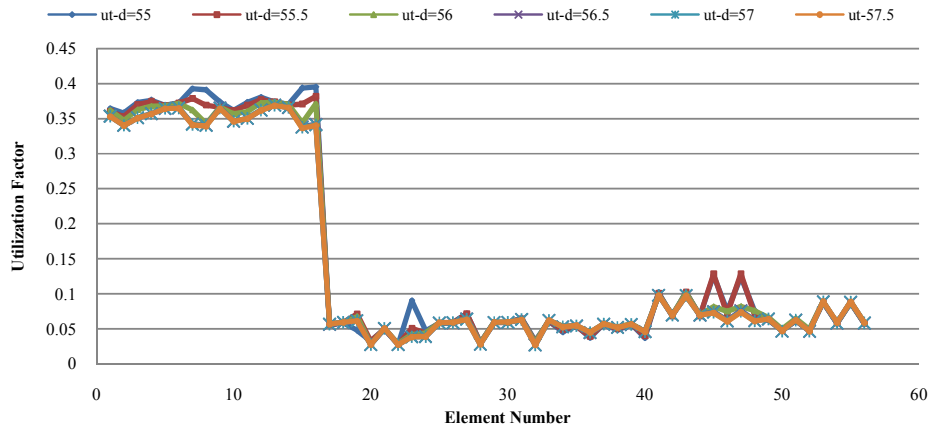

Fig. 17 The Ut-ratio variations for all of the jacket elements at different water depths (node-i)

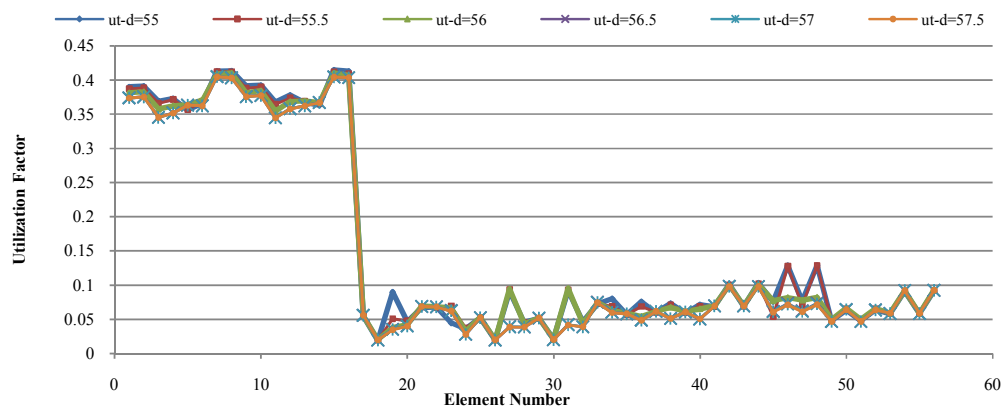

Fig. 18 The Ut-ratio variation for all of the jacket elements at different water depths (node-j)

VII. CONCLUSION

Jacket structures have been designed for a specific water level (LAT). One of the important issues about these structures is the water level rise. In this paper the main goal was to evaluate the structural elements responses due to water level rise. At first, the time history of the deck displacement has been investigated because this is an important factor for evaluating structural safety and serviceability. It was revealed that by increasing the jacket's design water depth, the time history response will show oscillation and the time shifting would happen between peaks of two different responses of the structural element in two different water depths. The second step in order to investigate the structural response of the jacket platform was to evaluate variations of Von-Mises stress. This investigation was based on the idea that the structural elements' Von-Mises stresses and utilization ratios would be increased by ascending the design water depth of the structure. However, the results were not in agreement with the expectations. Depending on the location of one structural element in the jacket structure and for one specific span of water level rise, its response will be different. For example, horizontal braces, leg elements and vertical braces have

different behaviors for the same water level rise. On the other hand, the variation of one specific element's response due to water level rise, itself, is completely different. In some cases, the structural element's response shows increase in the Von-Mises stress and utilization ratio and in other cases it shows decrease. The results of the RMS variations of Von-Mises stress show that some elements will tolerate about 50 percent increases in RMS's values. On the other hand, about 30 percent decrease will happen for some other elements. If the structure is designed for its marginal conditions, this increase can cause some disasters for its serviceability. Because of these random and unpredictable variations in structural elements responses, identifying their safety level after water level rise is very important and structure's reliability after the water level rise might be evaluated.

REFERENCES

- [1] G. Ersdal,(2005), "Assessment of existing offshore structures for life extension," Ph.D. thesis, Stavanger, Norway.
- [2] K. Sadeghi.,(1989), *Design and Analysis of Marine Structures*. tehran: Khajeh Nasiruddin Toosi University of Technology.
- [3] K. Sadeghi.,(2001), *Coasts, Ports and Offshore Structures Engineering*. tehran: Power and Water University of Technology.

- [4] C. Y. Son, *et al.*,(2008), "A Study on the Sensitivity of Dynamic Behavior of Jacket Type Offshore Structure".
- [5] D. Karunakaran.,(1993), "Nonlinear dynamic response and reliability analysis of drag-dominated offshore platforms," Ph.D. thesis, Trondheim, Norway.
- [6] J. J. Jesen, *et al.*,(1991), "Reliability of Jack-up Platforms against Overturning," *Marine Structures*, vol. 4, pp. 203-229.
- [7] J. W. Van de Graaf, *et al.*,(1993), "Failure Probability of Jack-up under Environmental Loading in the central North Sea," presented at the 4th International conference on The Jack-up Platform, Design, Construction and Operation, The City University London.
- [8] API RP 2A-WSD.,(2000)," Recommended Practice for Planning, Designing and Constructing Fixed Offshore Platforms—Working Stress Design," ed. Washington, D.C., USA: twenty first edition, American Petroleum Institute.
- [9] API RP 2A-LRFD.,(1993), "Recommended Practice for Planning, Designing and Constructing Fixed Offshore Platforms – Load and Resistance Factor Design," ed. Washington DC, USA: First Edition, American Petroleum Institute.
- [10] Norsok., (1998), Design of Steel Structures (Rev.1 ed.).
- [11] N. Shetty.,(1992), "System reliability of fixed offshore structures under fatigue deterioration," Ph.D. Thesis, Department of Civil Engineering, Imperial College of Science, Technology and Medicine, London.
- [12] J. I. Dalane.,(1993), "System Reliability in Design and Maintenance of Fixed Offshore Structures," Ph. D. Thesis, Department of Marine Structures, The Norwegian Institute of Technology, Trondheim, Norway.
- [13] M. Daghghi.,(1997), "Structural System Reliability Analysis of Jack-up Platforms under Extreme Environmental Conditions," Ph.D. Thesis, Delft University of Technology.
- [14] H. Nordal, *et al.*,(1987), "A Structural System Reliability Case Study of an Eight-leg Steel Jacket Offshore Production Platform," *The Society of Naval Architects and Marine Engineers*, pp. 193-216.
- [15] AISC.,(2010) " Specification for the design, fabrication and erection of structural steel for buildings. American Institute of Steel Construction," ed. Chicago, Illinois 60601-1802: American Institute of Steel Construction, Inc.
- [16] H. Nordal, *et al.*, "A Structural System Reliability Case Study of an Eight-leg Steel Jacket Offshore Production Platform," *The Society of Naval Architects and Marine Engineers*, pp. 193-216, 1987.
- [17] Ansys(2009).User's manual, revision 12.0, Swanson Analysis System, USA.
- [18] S. Zhang, *et al.*,(2011), "Dynamic analysis of a steel floating pipeline on sea," *Procedia Engineering*, vol. 12, pp. 60-65.
- [19] A. F. Bower.,(2009), ed. Rhode Island, USA: CRC Press 2009.

M.A Lotfollahi-Yaghin (First author)the Professor of Offshore Structural Engineering at the University of Tabriz, Iran, has a BSc degree in civil engineering from Isfahan University of Technology, Iran, an MSc degree in structural engineering from the University of Tabriz, and a PhD degree in offshore structural engineering from Herriot-Watt University, UK.

Professor Lotfollahi-Yaghin is the author of more than 60 technical papers and reports, and two books on finite element analysis and dynamics of offshore structures.