

Network Reconfiguration for Load Balancing in Distribution System with Distributed Generation and Capacitor Placement

T. Lantharthong, N. Rugthaicharoencheep

Abstract—This paper presents an efficient algorithm for optimization of radial distribution systems by a network reconfiguration to balance feeder loads and eliminate overload conditions. The system load-balancing index is used to determine the loading conditions of the system and maximum system loading capacity. The index value has to be minimum in the optimal network reconfiguration of load balancing. A method based on Tabu search algorithm, The Tabu search algorithm is employed to search for the optimal network reconfiguration. The basic idea behind the search is a move from a current solution to its neighborhood by effectively utilizing a memory to provide an efficient search for optimality. It presents low computational effort and is able to find good quality configurations. Simulation results for a radial 69-bus system with distributed generations and capacitors placement. The study results show that the optimal on/off patterns of the switches can be identified to give the best network reconfiguration involving balancing of feeder loads while respecting all the constraints.

Keywords—Network reconfiguration, Distributed generation Capacitor placement, Load balancing, Optimization technique

I. INTRODUCTION

THE electric power distribution systems consist of group of interconnected radial circuits and have a number of constraints like radial configuration, all loads served, coordinated operation of over current protective devices, and voltage drop within limits etc. Each feeder in the distribution system has a different mixture of commercial, residential and industrial type loads, with daily load variations. There are several operational schemes in electrical distribution systems; one of them is “distribution network reconfiguration”. There are some normally closed and normally opened switches (sectionalizing and the switches) in a distribution feeder [1], [2].

Network reconfiguration is very important for operating the distribution system. Generally, power distribution network reconfiguration provides services to as many customers as possible following fault coding and during planned outage for maintenance purposes with system loss minimization and load Balancing of the network [3].

Thong Lantharthong is with the Department of Electrical Engineering, Faculty of Engineering, Rajamangala University of Technology Phra Nakhon, Bangkok, 10800, Thailand. (phone: 662 913-2424; fax: 662 913-2424; e-mail: thong.l@rmutp.ac.th).

Nattachote Rugthaicharoencheep is with the Department of Electrical Engineering, Faculty of Engineering, Rajamangala University of Technology Phra Nakhon, Bangkok, 10800, Thailand. (phone: 662 913-2424 ext. 150; fax: 662 913-2424 ext. 151; e-mail: nattachote@ieee.org).

Network reconfiguration problem is a complex non-linear combinatorial problem due to non-differential status of switches and the normally open tie switches, determined to satisfy system requirement. From optimization point of view, the reconfiguration method have been used for loss reduction using different techniques on the other hand from service restoration point of view, the reconfiguration allows to relocate loads by using an appropriate sequence of switching operations with operating constraints taken into account [4].

Network reconfiguration of an electrical distribution system is an operation to alter the topological structure of distribution system by changing status (open/closed) of sectionalizing and tie switches. By transferring loads from the heavily loaded feeders to the relatively lightly loaded feeders, the network reconfiguration can balance feeder loads and eliminate overload conditions [5]. The system load-balancing index (LBI) is used to determine the loading conditions of the system and maximum system loading capacity. The index value has to be minimum in the optimal network reconfiguration of load balancing.

For load balancing, the loads are required to be rescheduled more efficiently by modifying the radial structure of the distribution feeders. There are many existing methods for determining feeder configuration. A Neural Network based method with mapping capability to identify various network configurations corresponding to different load levels was proposed in [6]. An experts system using heuristic rules to shrink the search space for reducing the computation time was presented in [7]. Kashem et al. [8] proposed an algorithm called “distance measurement technique” (DMT) that found a loop first and then a switching operation was determined in that loop to improve load balancing. Aoki et al. [9] formulated the load balancing and service restoration problems by considering the capacity and voltage constraints as a mixed integer nonlinear optimization problem and converted the problem into a series of continuous quadratic programming sub problems. Baran and Wu [10] formulated the problem of loss minimization and load balancing as an integer programming problem. H. D. Chiang et al. [11] proposed a constrained multi objective and non differentiable optimization problem with equality and inequality constraints for both loss reduction and load balancing. G. Peponis et al. [12] developed an improved switch-exchange method for load balancing problem, using switch exchange operations. Mukwanga [13] proposed a new load-balancing index and applied it to the network for load balancing. In [14] presented a new load balancing and unbalanced algorithm in distribution system for loss reduction.

Increasing trend of load growth in distribution systems and the necessity for constructing new power plants as its consequence, tendency toward applying clean energies and independence from fossil fuels, have caused distributed generation (DG) to draw attention to a great extent. Distributed generation (DG) is small-scale power generation that is usually connected to or embedded in the distribution system.

The benefits of DG are numerous and the reasons for implementing DGs are an energy efficiency or rational use of energy, deregulation or competition policy, diversification of energy sources, availability of modular generating plant, ease of finding sites for smaller generators, shorter construction times and lower capital costs of smaller plants and proximity of the generation plant to heavy loads, which reduces transmission costs [15]. Among advantages of DGs one can mention improvement in power quality and reliability and reduction of loss, meanwhile using DGs leads to complexity in operation, control and protection of distribution systems [16]. Injection of DGs currents to a distribution network results in losing radial configuration and consequently losing the existing coordination among protection devices.

The application of shunt capacitors in distribution systems has always been an important subject to distribution engineers. The general capacitor placement problem consists of determining the number, location, type, size and control settings at different load levels of the capacitors to be installed. Capacitors are widely installed in distribution systems for reactive power compensation to improve the efficiency of power distribution via power and energy loss reduction, to improve service quality via voltage regulation and to achieve deferral of construction, if possible, via system capacity release [17]. Capacitor placement in distribution feeder is the well known efficient method for improving overall power delivery in an electric distribution system. The power loss in distribution system is determined as function of square of branch current which consists of real and reactive component.

This paper emphasizes the advantage of network reconfiguration to the distribution system in the presence of DG units and capacitors placement for load balancing and bus voltage improvement. The application of Tabu Search is applied to determine the optimal on/off patterns of the switches to minimize the load balancing index subject to system constraints. The effectiveness of the methodology is demonstrated by a practical distribution system consisting of 69 buses.

II. POWER FLOW EQUATIONS

Power flow in a radial distribution network can be described by a set of recursive equations called dist flow branch equations that use the real power, reactive power and voltage at the sending end of a branch to express the same quantities at the receiving end of the branch [3]. Considering the single-line diagram depicted in Fig. 1

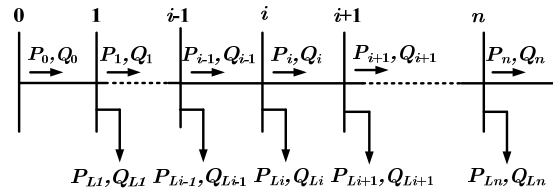

Fig. 1 Single-diagram of main feeder

$$P_{i+1} = P_i - P_{L(i+1)} - R_{i,i+1} \left[\frac{(P_i^2 + Q_i^2)}{|V_i|^2} \right] \quad (1)$$

$$Q_{i+1} = Q_i - Q_{L(i+1)} - X_{i,i+1} \left[\frac{(P_i^2 + Q_i^2)}{|V_i|^2} \right] \quad (2)$$

$$|V_{i+1}|^2 = V_i^2 - 2(R_{i,i+1}P_i + X_{i,i+1}Q_i) + (R_{i,i}^2 + X_{i,i+1}^2) \left[\frac{(P_i^2 + Q_i^2)}{|V_i|^2} \right] \quad (3)$$

The power loss of the line section connecting between buses i and $i+1$ may be computed as

$$P_{Loss}(i, i+1) = R_{i,i+1} \left[\frac{(P_i^2 + Q_i^2)}{|V_i|^2} \right] \quad (4)$$

where P_i, Q_i = active and reactive power at bus i

V_i = voltage of bus i

$R_{i,i+1}$ = resistance of line section between buses i and $i+1$

$X_{i,i+1}$ = reactance of line section between buses i and $i+1$

III. TABU SEARCH

A. Background

Tabu search is a meta-heuristic that guides a local heuristic search strategy to explore the solution space beyond local optimality. Tabu search was developed by Glover and has been used to solve a wide range of hard optimization problems, such as resource planning, telecommunications, financial analysis, scheduling, space planning, and energy distribution [18].

The basic idea behind the search is a move from a current solution to its neighborhood by effectively utilizing a memory to provide an efficient search for optimality. The memory is called "Tabu list", which stores attributes of solutions. In the search process, the solutions are in the Tabu list cannot be a candidate of the next iteration. As a result, it helps inhibit choosing the same solution many times and avoid being trapped into cycling of the solutions [19].

The quality of a move in solution space is assessed by aspiration criteria that provide a mechanism for overriding the Tabu list shown in Figure 2. Aspiration criteria are analogous to a fitness function of the genetic algorithm and the Boltzman function in the simulated annealing.

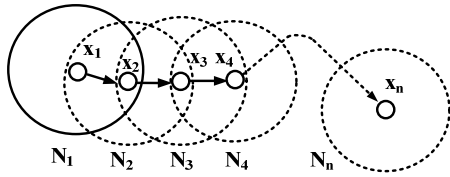

Fig. 2 Mechanism of Tabu list

B. Neighborhood

In the search process, a move to the best solution in the neighborhood, although its quality is worse than the current solution, is allowed. This strategy helps escape from local optimal and explore wider in the search space. A Tabu list includes recently selected solutions that are forbidden to prevent cycling. If the move is present in the Tabu list, it is accepted only if it has a better aspiration level than the minimal level so far. Fig. 3 [20] shows the main concept of a search direction in Tabu search.

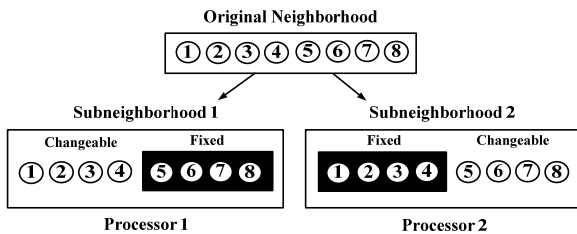

Fig. 3 Search direction of Tabu search

IV. PROBLEM FORMULATION

Loading balance index (LBI) represents the degree of loading among feeders. The objective of this optimization problem can be expressed by the minimization of the load balancing index (LBI) as in equation (5) [12]:

$$\text{Min LBI} = \sum_{k \in B} L_k \left(\frac{|I_{k,t}|}{I_k^{\text{max}}} \right)^2 \tag{5}$$

- where B = set of net work branches forming loops
- L_k = length of branch k
- $I_{k,t}$ = current capability of branch k for feeder reconfiguration pattern t
- I_k^{max} = maximum current capability of branch k

The objective function in (5) is subject to the following constraints.

- 1) Power flow equations.
- 2) The voltage magnitude at each bus must be maintained within its limits expressed as follows:

$$V_{\text{min}} \leq |V_i| \leq V_{\text{max}} \tag{6}$$

- 3) Feeder capability limits:

$$|I_k| \leq I_{k,\text{max}} : k \in \{1, 2, 3, \dots, J\} \tag{7}$$

- 4) Radial configuration format.
- 5) No load-point interruption.

where V_i = voltage at bus i

$V_{\text{min}}, V_{\text{max}}$ = minimum and maximum voltage

I_k = current flow in branch k

$I_{k,\text{max}}$ = maximum current capability of branch k

A flowchart for solving the problem is shown in Figure 4.

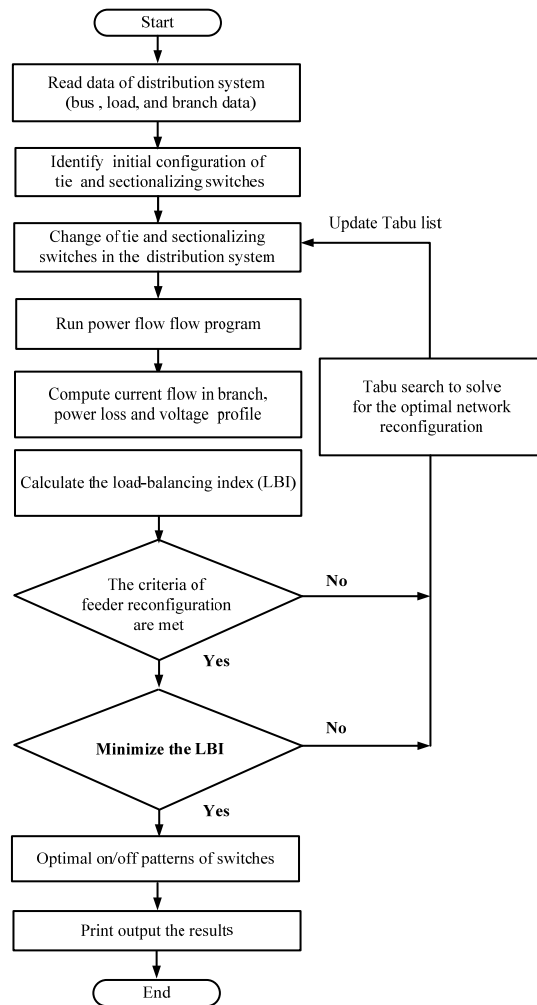

Fig. 4 Flowchart of network reconfiguration for load balancing

V. CASE STUDY

The test system for the case study is a 12.66 kV radial distribution system with 69 buses, 7 laterals and 5 tie-lines (looping branches), with distributed generation and capacitor placements as shown in Figure 5. The current carrying capacity of branch No.1-9 is 400 A, No. 46-49 and No. 52-64

are 300 A and the other remaining branches including the tie lines are 200 A. Each branch in the system has a sectionalizing switch for reconfiguration purpose. The load data are given in appendix Table AI and branch data in Table AII [21].

DGs are 4 small power producers who can provide only firm active power to the system by their DG units. The producers are located at buses 14, 35, 36, and 53 with capacities of 300, 200, 100, and 400 kW, respectively.

Capacitor located at buses 24, 45, 49, and 61 with capacities of 100, 200, 300, and 400 kVAr, respectively.

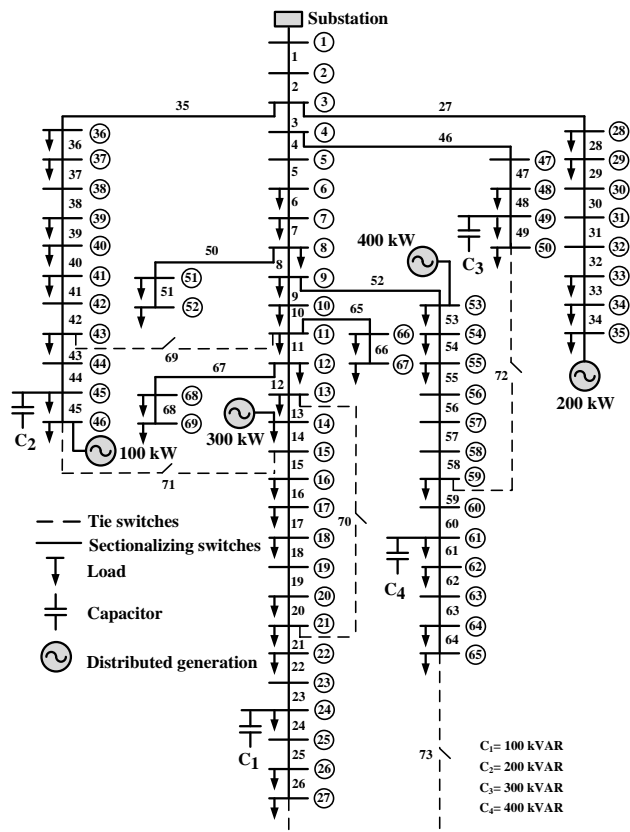

Fig. 5 Test system of 69-bus radial distribution with distributed generation and capacitor placements

The initial statuses of all the sectionalizing switches (switches No. 1-68) are closed while all the tie-switches (switch No. 69-73) open. The total loads for this test system are 3,801.89 kW and 2,694.10 kVAr. The feeder configuration algorithm, based on Tabu search is used to search the most appropriation topology of the system. The minimum and maximum voltages are set at 0.95 and 1.05 p.u. The maximum iteration for the Tabu search algorithm is 100.

The five cases are examined for network reconfiguration for load balancing in distribution system with distributed generation and capacitor placement in Table I.

TABLE I
CASE STUDY FOR LOAD BALANCING IN DISTRIBUTION SYSTEM

Case	Network Reconfiguration	DGs Placement	Capacitor Placement
1	-	-	-

2	✓	-	-
3	✓	✓	-
4	✓	-	✓
5	✓	✓	✓

The test results for the five cases are summarized in Table II and Table III. In case 1, the system power loss and the LBI are highest, and the minimum bus voltage in the system violates the lower limit of 0.95 per unit. It is confirmed from case 3 that the distributed generation help reduce the system loss from 224.68 kW to 84.38 kW The minimum load balancing index (LBI) is 1.442 and power loss is 77.604 kW seen in case 5, where there are changes in branch currents after the reconfiguration. In cases 2 and 5, all bus voltages satisfy the 0.95 p.u-voltage constraint.

TABLE II
RESULTS FOR CASE STUDY 1, 2 AND 3

	Case 1	Case 2	Case 3
Sectionalizing switches to be open	-	13, 20, 58, 63	14, 20, 52, 61
Tie switches to be closed	-	70, 71, 72, 73	70, 71, 72, 73
Load balancing index (LBI)	2.949	2.197	1.685
Minimum voltage (p.u.)	0.909	0.948	0.955
Total power loss (kW)	224.68	105.65	84.38

TABLE III
RESULTS FOR CASE STUDY 4 AND 5

	Case 4	Case 5
Sectionalizing switches to be open	14, 20, 52, 61	14, 20, 53, 62
Tie switches to be closed	70, 71, 72, 73	70, 71, 72, 73
Load balancing index (LBI)	1.796	1.442
Minimum voltage (p.u.)	0.956	0.955
Total power loss (kW)	108.94	77.604

VI. CONCLUSION

In this paper, an efficient joint strategy for network reconfiguration in distribution systems with distributed generation and capacitor placements. The application of Tabu Search is applied to determine the optimal on/off patterns of the switches to minimize the load balancing index subject to system constraints. Load balancing are important complement to network and feeder reconfiguration. Test results indicate that the method can identify the most effective network reconfiguration for improvement in load balancing. It is found that the optimal or near optimal configuration for load balancing also loss reduction and improves the voltage profile of the network while satisfying all the constraints. Simulations for a test system as well as a realistic system demonstrated the potential of use of the proposed technique that can be an useful tool for distribution systems planning and operation.

APPENDIX I
LOAD DATA OF 69-BUS DISTRIBUTION SYSTEM

Bus Number	P _L (kW)	Q _L (kVAr)	Bus Number	P _L (kW)	Q _L (kVAr)
6	2.60	2.20	37	26.00	18.55
7	40.40	30.00	39	24.00	17.00
8	75.00	54.00	40	24.00	17.00
9	30.00	22.00	41	1.20	1.00
10	28.00	19.00	43	6.00	4.30
11	145.00	104.00	45	39.22	26.30

APPENDIX I (Continued)

Bus Number	P _L (kW)	Q _L (kVAr)	Bus Number	P _L (kW)	Q _L (kVAr)
12	145.00	104.00	46	39.22	26.30
13	8.00	5.00	48	79.00	56.40
14	8.00	5.50	49	384.70	274.50
16	45.50	30.00	50	384.70	274.50
17	60.00	35.00	51	40.50	28.30
18	60.00	35.00	52	3.60	2.70
20	1.00	0.60	53	4.35	3.50
21	114.00	81.00	54	26.40	19.00
22	5.00	3.50	55	24.00	17.20
24	28.00	20.00	59	100.00	72.00
26	14.00	10.00	61	1244.00	888.00
27	14.00	10.00	62	32.00	23.00
28	26.00	18.60	64	227.00	162.00
29	26.00	18.60	65	59.00	42.00
33	14.00	10.00	66	18.00	13.00
34	19.50	14.00	67	18.00	13.00
35	6.00	4.00	68	28.00	20.00
36	26.00	18.55	69	28.00	20.00

APPENDIX II
BRANCH DATA OF 69-BUS DISTRIBUTION SYSTEM

Branch Number	Sending end bus	Receiving end bus	R (Ω)	X (Ω)
1	1	2	0.0005	0.0012
2	2	3	0.0005	0.0012
3	3	4	0.0015	0.0036
4	4	5	0.0251	0.0294
5	5	6	0.3660	0.1864
6	6	7	0.3811	0.1941
7	7	8	0.0922	0.0470
8	8	9	0.0493	0.0251
9	9	10	0.8190	0.2707
10	10	11	0.1872	0.0619
11	11	12	0.7114	0.2351
12	12	13	1.0300	0.3400
13	13	14	1.0440	0.3450
14	14	15	1.0580	0.3496
15	15	16	0.1966	0.0650
16	16	17	0.3744	0.1238
17	17	18	0.0047	0.0016
18	18	19	0.3276	0.1083
19	19	20	0.2106	0.0690
20	20	21	0.3416	0.1129
21	21	22	0.0140	0.0046
22	22	23	0.1591	0.0526
23	23	24	0.3463	0.1145
24	24	25	0.7488	0.2475
25	25	26	0.3089	0.1021
26	26	27	0.1732	0.0572
27	3	28	0.0044	0.0108
28	28	29	0.0640	0.1565
29	29	30	0.3978	0.1315
30	30	31	0.0702	0.0232
31	31	32	0.3510	0.1160
32	32	33	0.8390	0.2816
33	33	34	1.7080	0.5646
34	34	35	1.4740	0.4873
35	3	36	0.0044	0.0108
36	36	37	0.0640	0.1565
37	37	38	0.1053	0.1230
38	38	39	0.0304	0.0355
39	39	40	0.0018	0.0021
40	40	41	0.7283	0.8509
41	41	42	0.3100	0.3623
42	42	43	0.0410	0.0478
43	43	44	0.0092	0.0116
44	44	45	0.1089	0.1373
45	45	46	0.0009	0.0012
46	4	47	0.0034	0.0084
47	47	48	0.0851	0.2083

APPENDIX II (Continued)

Branch Number	Sending end bus	Receiving end bus	R (Ω)	X (Ω)
48	48	49	0.2898	0.7091
49	49	50	0.0822	0.2011
50	8	51	0.0928	0.0473
51	51	52	0.3319	0.1114
52	9	53	0.1740	0.0886
53	53	54	0.2030	0.1034
54	54	55	0.2842	0.1447
55	55	56	0.2813	0.1433
56	56	57	1.5900	0.5337
57	57	58	0.7837	0.2630
58	58	59	0.3042	0.1006
59	59	60	0.3861	0.1172
60	60	61	0.5075	0.2585
61	61	62	0.0974	0.0496
62	62	63	0.1450	0.0738
63	63	64	0.7105	0.3619
64	64	65	1.0410	0.5302
65	11	66	0.2012	0.0611
66	66	67	0.0047	0.0014
67	12	68	0.7394	0.2444
68	68	69	0.0047	0.0016
Tie line				
69	11	43	0.5000	0.5000
70	13	21	0.5000	0.5000
71	15	46	1.0000	0.5000
72	50	59	2.0000	1.0000
73	27	65	1.0000	0.5000

ACKNOWLEDGMENT

The authors would like to express his gratitude to Rajamangala University of Technology Phra Nakhon, Thailand for support.

REFERENCES

- [1] D. Das, "A fuzzy multiobjective approach for network reconfiguration of distribution systems," *IEEE Trans. Power Delivery*, vol. 21, no. 1, pp. 1401-1407, Jan. 2006.
- [2] P. Ravibabu, K. Venkatesh, and C. S. Kumar, "Implementation of genetic algorithm for optimal network reconfiguration in distribution systems for load balancing," in *Proc Conf. Computation Technology in Electrical and Electronics Engineering*, Novosibirsk, 2008, pp.124-128.
- [3] C. T. Su, and C. S. Lee, "Network reconfiguration of distribution systems using improved mixed-integer hybrid differential evolution," *IEEE Trans. Power Delivery*, vol. 18, no. 3, pp. 1022-1027, July 2003.
- [4] Y. K. Wu, and et al., "Study of Reconfiguration for the distribution system with distributed generators," *IEEE Trans. Power Delivery*, vol. 25, no. 3, pp. 1678-1685, July 2010.
- [5] E. Carpaneto, G. Chicco, and J. S. Akilimali, "Branch current decomposition method for loss allocation in radial distribution systems with distributed generation," *IEEE Trans. Power Systems*, vol. 21, no. 3, pp. 1170-1179, Aug. 2006.
- [6] H. Kim, Y. ko, and K. H. Jung, "Artificial neural network based feeder reconfiguration for loss reduction in distribution systems," *IEEE Trans Power Delivery*, vol. 8, no. 3, pp. 1356-1366, July 1993.
- [7] T. Taylor, and D. Lubkeman, "Implementation of heuristic search strategies for distribution feeder reconfiguration," *IEEE Trans Power Delivery*, vol. 5, no. 1, pp.239-246, Jan. 1990.
- [8] M. A. Kashem, V. Ganapathy, and G. B. Jasmon, "Network reconfiguration for load balancing in distribution networks," *IEE Proc.-Gener. Transm. Distrib.*, vol. 146, no. 6, pp. 563-567, Nov. 1999.
- [9] K. Aoki, and et al., "An efficient algorithm for load balancing of transformers and feeders," *IEEE Trans. Power Delivery*, vol. 3, no. 4, pp. 1865-1872, Oct. 1988.
- [10] M. E. Baran, and F. F. Wu, "Network reconfiguration in distribution systems for loss reduction and load balancing," *IEEE Trans. Power Delivery*, vol. 4, no. 2, pp. 1401-1407, Apr. 1989.
- [11] H. D. Chiang, and R.J Jumeau, "Optimal network reconfigurations in distribution systems: Part 1: A new formulation and a solution

- methodology," *IEEE Trans. Power Delivery*, vol. 5, no. 4, pp. 1902-1909, Nov. 1990.
- [12] G. Pepionis, and M. Papadopoulos, "Reconfiguration of radial distribution networks: application of heuristic methods on large-scale networks," *IEE Proc., Gener., Transm. Distrib.*, vol. 142, no. 6, pp. 631 – 638, Nov. 1995.
- [13] Mukwanga and et al., "Reconfiguration and load balancing in the LV and MV distribution networks for optimal performance," *IEEE Trans. on Power Delivery*, vol. 22, no. 4, pp. 2534-1407, Oct. 2007.
- [14] G. K. V. Raju, and P.R. Bijwe, "Efficient reconfiguration of balanced and unbalanced distribution systems for loss minimization," *IEE Proc.-Gener. Transm. Distrib.*, vol. 2, no. 1, pp. 7-12, Jan. 2008.
- [15] H. A. Gil, and G. Joos, "Models for quantifying the economic benefits of distributed generation," *IEEE Trans. Power Systems*, vol. 23, no 2, pp. 327-335, May 2008.
- [16] G. Levitin, and et al., "Optimal capacitor allocation in distribution systems using a genetic algorithm and a fast energy loss computation technique," *IEEE Trans. on Power Delivery*, vol. 15, no 2, pp. 623-628, Oct. 2000.
- [17] V. H. M. Quezada, J. R. Abbad, and T. G. S. Roman, "Assessment of energy distribution losses for increasing penetration of distributed generation," *IEEE Trans. Power Systems*, vol. 21, no. 2, pp. 533-540, May 2006.
- [18] B. Dengiz, and C. Alabas, "Simulation optimization using tabu search," in *Conf. Winter Simulation*, 2000, pp. 805-810.
- [19] F. Glover, "Tabu search-part 1," *ORSA J. Computing*, vol. 1, no.3, 1989.
- [20] H. Mori, and Y. Ogita, "Parallel tabu search for capacitor placement in radial distribution system," in *Conf. Power Engineering Society Winter Meeting*, 2002, pp 2334-2339.
- [21] J. S. Savier, and D. Das, "Impact of network reconfiguration on loss allocation of radial distribution systems," *IEEE Trans. Power Delivery*, vol. 22, no. 4, pp. 2473-2480, Oct. 2007.

Thong Lantharthong received his M.Eng in Electrical Engineering from Rajamangala University of Technology Thanyaburi, Thailand in 2010. He is currently a lecturer at the Department of Electrical Engineering, Faculty of Engineering, Rajamangala University of Technology Phra Nakhon (RMUTP), Bangkok, Thailand. His research interests include, power system planning, optimization technique, and renewable energy.

Nattachote Rugthaicharoencheep (M'10) received his Ph.D. in Electrical Engineering from King Mongkut's University of Technology North Bangkok (KMUTNB), Thailand in 2010. He is currently a lecturer at the Department of Electrical Engineering, Faculty of Engineering Rajamangala University of Technology Phra Nakhon (RMUTP), Bangkok, Thailand. His research interests include power system operation, optimization technique, and distributed generation.