

# Multiple Peaks Tracking Algorithm using Particle Swarm Optimization Incorporated with Artificial Neural Network

Mei Shan Ngan, Chee Wei Tan

**Abstract**—Due to the non-linear characteristics of photovoltaic (PV) array, PV systems typically are equipped with the capability of maximum power point tracking (MPPT) feature. Moreover, in the case of PV array under partially shaded conditions, hotspot problem will occur which could damage the PV cells. Partial shading causes multiple peaks in the P-V characteristic curves. This paper presents a hybrid algorithm of Particle Swarm Optimization (PSO) and Artificial Neural Network (ANN) MPPT algorithm for the detection of global peak among the multiple peaks in order to extract the true maximum energy from PV panel. The PV system consists of PV array, dc-dc boost converter controlled by the proposed MPPT algorithm and a resistive load. The system was simulated using MATLAB/Simulink package. The simulation results show that the proposed algorithm performs well to detect the true global peak power. The results of the simulations are analyzed and discussed.

**Keywords**—Photovoltaic (PV), Partial Shading, Maximum Power Point Tracking (MPPT), Particle Swarm Optimization (PSO) and Artificial Neural Network (ANN)

## I. INTRODUCTION

PHOTOVOLTAIC (PV) energy is one of the most promising alternative energy due to the advantages such as it is clean, inexhaustible, free to harvest and little maintenance fees [1]. However, there are two factors that limit the implementation of PV systems, which include the high installation cost and the low efficiency in energy conversion. The recent PV array conversion efficiency is only in the range of 9-17 % [1-2]. In other words, there are more than 80% of solar energy are not converted into useful electrical energy but loss in the environment. Therefore, a maximum power point tracking (MPPT) converter is an essential part of PV power generation systems. MPPT converters are used to extract the maximum available power from PV array in order to maximize the utilization efficiency of PV array [1, 3]. PV energy is a non-linear source, it is very much depends on the state of load and weather such as PV cell temperature and solar irradiance variations [4]. It can be noticed that PV output voltage is greatly governed by temperature change while PV output current is directly proportionate to the solar irradiance change as shown in Fig.1 and Fig. 2. Typically, a DC-DC converter is inserted between the PV generator and the load for control purpose. The duty-cycle of the DC-DC converter is

controlled by a MPPT algorithm using pulse width modulation technique [4].

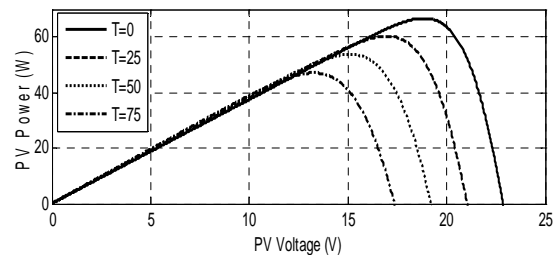

Fig. 1 P-V characteristics of a typical PV module under a series of temperatures

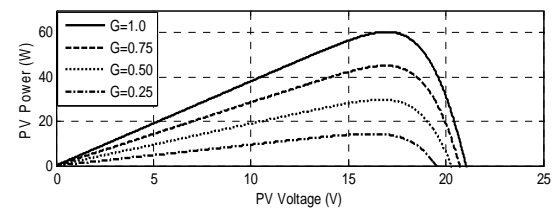

Fig. 2 P-V characteristics of a typical PV module under a series of solar irradiances

There have been extensive research been done to design suitable MPPT algorithms to extract the maximum power from the PV array. However, most of those focused on peak power tracking under uniform and full illumination [5-6]. The preferred MPPT algorithms include Perturb and Observe (P&O), Incremental Conductance (Inc.Cond), off-line control method and *etc.* The P&O algorithm perturbs the PV array's terminal voltage periodically, and then it compares the PV output power with that of the previous cycle of perturbation [7]. The Inc.Cond algorithm compares the instantaneous conductance to the incremental conductance in order to search the maximum power point (MPP) [8]. Meanwhile, the off-line MPPT methods such as the Open-Circuit PV Voltage and the Short-Circuit PV Current methods are based on the linear relationship between the output voltage ( $V_{MPP}$ ) and output current ( $I_{MPP}$ ) of the PV array at MPP, with the PV array's open-circuit voltage ( $V_{OC}$ ) and the short-circuit current ( $I_{SC}$ ) as in [5-6]. Other existing algorithms include the artificial intelligent methods such as Fuzzy Logic method, Neural Network method and some other hybrid methods. These algorithms are used to track the MPP effectively so that the PV system can deliver the maximum solar energy yield to the load. When PV array operates under non-uniform conditions

Mei Shan Ngan is a master student in Department of Energy Conversion, Faculty of Electrical Engineering, Universiti Teknologi Malaysia.

Chee Wei Tan is a lecturer, PhD holder in Department of Energy Conversion, Faculty of Electrical Engineering, Universiti Teknologi Malaysia. Tel: +607-5535768, Fax: +607-5566272 (email: cheewei@fke.utm.my)

(under partially shaded conditions), the P-V characteristic and the output power curve could yield different characteristic from the one with uniform insolation [9]. Besides that, the output power will drop significantly and hence the efficiency of the PV system is limited [3, 9]. Therefore, the key issue in this paper is to propose a MPPT algorithm to counteract the power loss problem of PV array under partially shaded conditions. In this paper, PV array under partial shaded conditions will be further discussed. The MPPT method, which is a hybrid method of Particle Swarm Optimization and Artificial Neural Network algorithms will be described. The simulation results are analyzed and discussions are made. Finally, conclusions are drawn based on the simulation of the proposed MPPT method.

## II. PV ARRAYS UNDER PARTIAL SHADED CONDITIONS

In PV system, PV modules are connected in series and parallel to obtain the desired voltage level [10-12]. However, of all the PV arrays, not every module receives the same amount of solar energy (striking of photons on the PV module) at all time. There are times where some part of the PV arrays might be shaded by heavy cloud, trees, or nearby buildings [9, 13]. The shaded PV cells absorb a large amount of electric power generated by other PV cells that receive high illumination and convert it into heat. This situation is called the hot-spot problem, which may damage the PV cells with low illumination [11-12, 14]. In order to relieve the stress on the shaded PV cells, bypass diodes are normally connected in parallel with each PV modules. The inserted bypass diodes may cause multiple peaks are established in the P-V characteristic curves under partial shaded conditions as shown Fig. 3 [9, 14-16].

In this work, a P-V characteristic curve is simulated using six PV models that were connected in series, as shown in Fig. 4. Each PV module is modeled based on the specifications of PV module P1310X990 which the specification is tabulated in Table 1. In the simulation model, the solar irradiances act as the inputs of the PV models and in which it is varied to emulate partially shaded condition.

In general, most of the conventional MPPT algorithms as mentioned previously do not have the capability to detect the global peak (the true maximum among the multiple local peaks) effectively which will lead to considerable power loss [9, 12, 16]. Therefore, the conventional MPPT algorithms should be further modified or new MPPT algorithms should be proposed to solve the hot-spot problem when PV system is under partially shaded conditions.

Reference [3] proposed a method based on Incremental Conductance method with step size variation. The algorithm changed the voltage reference by the linear function proposed, the operating point is searched in the same manner of the conventional Inc.Cond. Authors in references [17-18] proposed PSO technique to control several PV arrays with one pair of voltage and current sensors. They mentioned that this multi-dimensional search-based technique is able to detect the global MPP and also compared some other MPPT techniques with PSO technique. In literature [19], the authors proposed DIRECT search method to detect the global MPP. This method applied two main ideas which are the area dividing strategies and the

potentially optimal intervals (POI) technique. Engin Karatepe *et al.* [20] proposed a voltage based power compensation method to reduce the power loss due to partial shading, they described that this method guaranteed obtaining global MPP in any partial shaded conditions. Hiren Patel and Vivek Agarwal [21] proposed a new MPPT algorithm that worked in conjunction with a dc-dc converter to track the global MPP; in which a feed-forward control scheme for operating the dc-dc converter is proposed where the reference voltage is compared with the tracking algorithm to shift the operation toward MPP.

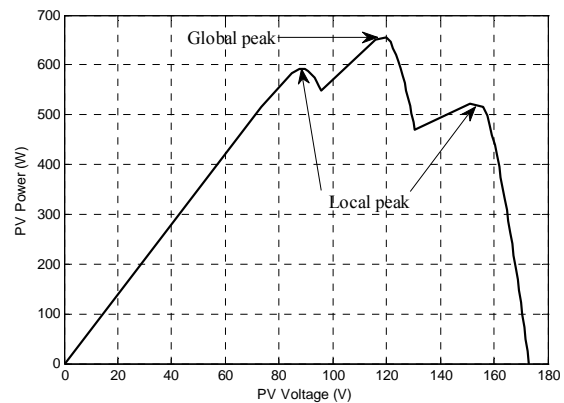

Fig. 3 P-V characteristic curve of six PV modules connected in series under partial shaded condition featuring multiple peaks

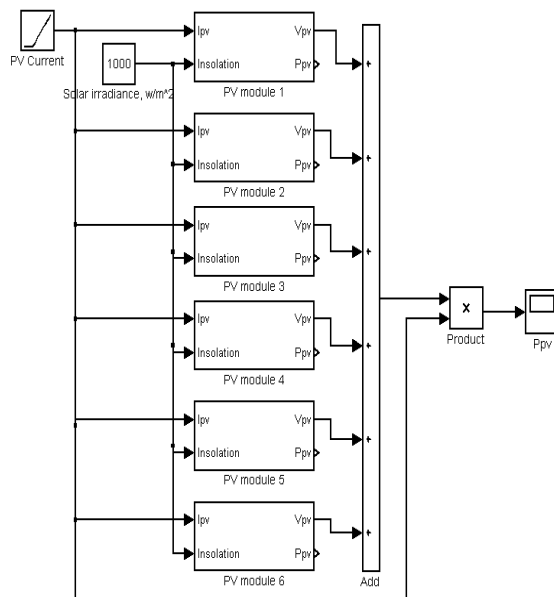

Fig. 4 Simulation model of six PV models connected in series implemented in Simulink

TABLE I  
THE SPECIFICATIONS OF PV MODULE P1310x990

At temperature	25 °C
Open circuit voltage, $V_{OC}$	29 V
Short circuit current, $I_{SC}$	7.2 A
Voltage at maximum power, $V_{MPP}$	22.5 V
Current at maximum power, $I_{MPP}$	6.7 A
Maximum power, MPP	150 W

### III. PROPOSED METHOD

#### A. Particle Swarm Optimization Algorithm

In this paper, a hybrid method of Particle Swarm Optimization (PSO) algorithm trained by Artificial Neural Network (ANN) is proposed. The PSO algorithm is used to detect the output current of PV array at MPP, whereby some of the parameters of PSO algorithm are trained by ANN when there is a change of solar irradiance.

Particle swarm optimization (PSO) was introduced by James Kennedy and Russell C. Eberhart in 1995 [22-23]. It is a population based stochastic optimization technique used to determine the required parameters by maximizing the objective function in a given search space. It is a simple and an effective technique which can be applied to multi-variable function optimization with multiple local points. The typical application in some basic areas include function optimization, neural network training and several important engineering applications [22, 24].

PSO has two primary operators, which are the velocity update and the position update. The PSO uses several particles or agents to search for the maximum or minimum values of an objective functions [17-18, 25]. Each of the agent moves in a given searchspace with a velocity,  $v_i^k$ . Then, a new velocity value for each agent is calculated based on the current velocity, the previous best position and the global best position, for each iteration [24]. Later, the new position is updated by using the previous position and the new velocity value. The velocity and position of the agents will be updated according to equations as follow [17-18].

$$v_i^{k+1} = wv_i^k + c_1r_1(p_{besti} - s_i^k) + c_2r_2(g_{best} - s_i^k) \quad (1)$$

$$s_i^{k+1} = s_i^k + v_i^{k+1} \quad (2)$$

where

- $v_i^k$  = current velocity vector
- $v_i^{k+1}$  = modified velocity vector
- $s_i^k$  = current position vector
- $s_i^{k+1}$  = modified position vector
- $w$  = inertia weight
- $p_{besti}$  = best position found by particle  $i$
- $g_{best}$  = best position found by particle group
- $c_1$  = cognitive coefficient
- $c_2$  = social coefficient
- $r_1$  = random parameter, [0,1]
- $r_2$  = random parameter, [0,1]

#### B. Artificial Neural Network Algorithm

Artificial neural network (ANN) is a type of network that sees the nodes as 'artificial neurons'. Neurons receive signals

through synapses on the dendrites tree. When the signals received exceed a certain threshold, the neurons are activated and transmitted along the axon to other neurons. Hence, an artificial system with comparable computational capacity will display human like intelligent behavior [26-27]. ANN algorithm has been widely used in physics, computer science, mathematics, image processing, economics, telecommunications *etc.*[28-29]. ANN consists of inputs which are multiplied by weights, it is then computed by a mathematical function which determines the activation of the neuron, while the output of the artificial neuron is computed by another function [26]. There are three layers in ANN, which include the input layer, hidden layer and output layer. The mathematical function is a transfer function for hidden layer and output layer. Those transfer functions include *tansig* function (inverse tangent sigmoidal function), *logsig* function (logarithm sigmoidal function) and *purelin* function (linear function)[26, 30]. The process of adjusting the weights is called learning or training. The weights are adapted through a continuing process of simulation. There are two types of learning process, namely supervised learning and unsupervised learning [26, 30]. In a supervised learning, a training sample where the examples of inputs and outputs that we want the network to compute, the errors are computed so that the actual output of the neural network is close enough to the training data. Meanwhile, the weights under unsupervised learning are adjusted through the use of neurobiological principles such as Hebbian learning and competitive learning [30]. This process will not be discussed further due to its complexity and constraint of space. A multi-layer perceptron (MLP) consists of three layers (input, hidden and output layers), which applied feed-forward back-propagation algorithm [30]. The artificial neurons send their signals forward, and the errors are propagated backwards. The errors are reduced by the back-propagation algorithm, until the ANN learns the training data.

#### C. Hybrid of PSO and ANN Algorithms

Table II tabulates the design specifications of the ANN algorithm in MATLAB/Simulink used in this simulation. It shows the functions utilized for the ANN algorithm, the inputs parameter and the outputs generated by the algorithm. There were 50 epochs, which were the total number of operations needed to train the data.

Fig. 5 shows the flow chart of the hybrid PSO and ANN algorithms which applied to control the switching of the dc-dc converter. During the initialization process, number of particles is set, the position and the velocity of the particles are initialized randomly or by given certain values.

In this work, three particles ( $M=3$ ) was used. The positions of the particle were referred as the initial values of PV current ( $I_c$ ), which was produced by the ANN algorithm. The initial velocities of all particles were set to zero. There are three parameters of PSO algorithm needed to be determined, namely the weight inertia ( $w$ ), cognitive coefficient ( $c_1$ ) and the social coefficient ( $c_2$ ). The values of the parameters were determined by try and error method, and they were set as 0.5, 1.2 and 1.6, respectively.

TABLE II  
THE DESIGN SPECIFICATIONS OF ANN ALGORITHM

Title	Specifications
Network type	Feed-forward neural network
Number of layers	3 layers (10 nodes in hidden layer)
Transfer function	(i) Tangent sigmoid ( <i>tansig</i> ) function in hidden layer (ii) Linear ( <i>purelin</i> ) function for output layer
Training function	Gradient descent with momentum back-propagation function
Number of inputs	3 inputs (corresponding PV currents for varied solar irradiances)
Number of outputs	2 outputs (deltaP and initial PV current)
Number of epochs	50

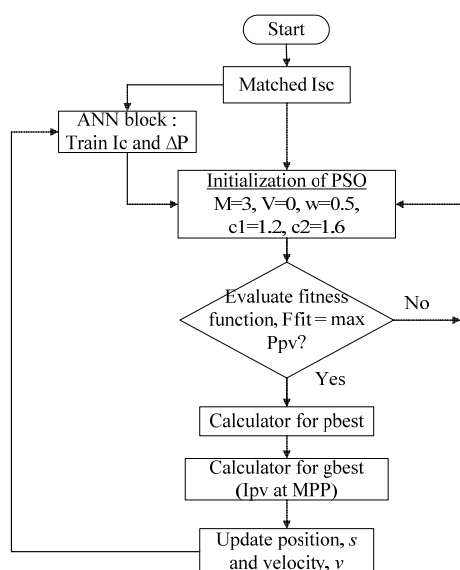

Fig. 5 Flow chart of hybrid PSO and ANN algorithm

The fitness function for each agent was evaluated. The maximum or minimum value of the fitness function was determined depends the optimization criteria. In this case, the PV power generated is the fitness function that should be maximized, while the output current of the PV system is the variable that changes throughout the time in order to measure the power,  $P(s)$ . The best position found (the PV current at MPP) by particle,  $p_{best}$  was determined follow by the best position found by particle group,  $g_{best}$ . Next, the velocity and the position were updated. The fitness function was evaluated based on the new velocity and the new position. The process was iterated in a number of times, or until a minimum error, or a maximum values was achieved. In practice, the PV system is in real-time operation, the fitness function will change due to the rapid change of the environmental conditions as the PV voltage and current changes too. The particles should be reinitialized to search the new MPP whenever the following condition is satisfied.

$$|P(s_{i+1}) - P(s_i)| / P(s_i) > \Delta P \quad (3)$$

The ANN algorithm was trained to obtain the values of  $\Delta P$  and the initial values of PV current when there was a change in the solar irradiance. There were 100 samples of data for the values of  $\Delta P$  and  $I_c$  corresponding to different combinations of solar irradiance change, which were trained by the ANN algorithm. Each of the values of  $\Delta P$  and  $I_c$  was obtained by trial and error to achieve the maximum power when there is a change of solar irradiance. Table 3 presents the five samples of data used in the ANN algorithm, where the  $I_{sc}$  is the short circuit current of PV module.

TABLE III  
FIVE SAMPLES THAT TRAINED BY THE ANN ALGORITHMS

Solar irradiance, $(G_1, G_2, G_3)$ $W/m^2$ ,	Power Change, $\Delta P$ , (dimensionless)	Initial PV current, $I_c$ (A)
1000, 900, 500	0.166	$0.85I_{sc}, 0.86I_{sc}, 0.87I_{sc}$
1000, 800, 300	0.266	$0.75I_{sc}, 0.76I_{sc}, 0.77I_{sc}$
1000, 500, 200	0.522	$0.94I_{sc}, 0.95I_{sc}, 0.96I_{sc}$
1000, 700, 400	0.411	$0.93I_{sc}, 0.94I_{sc}, 0.95I_{sc}$
1000, 600, 300	0.495	$0.93I_{sc}, 0.94I_{sc}, 0.95I_{sc}$

#### IV. SIMULATION

Figure 6 shows the simulation blocks that was built in the MATLAB/Simulink. It consists of a PV array, a boost (step-up) converter, a resistive load, a hybrid ANN-PSO algorithm and a PID controller.

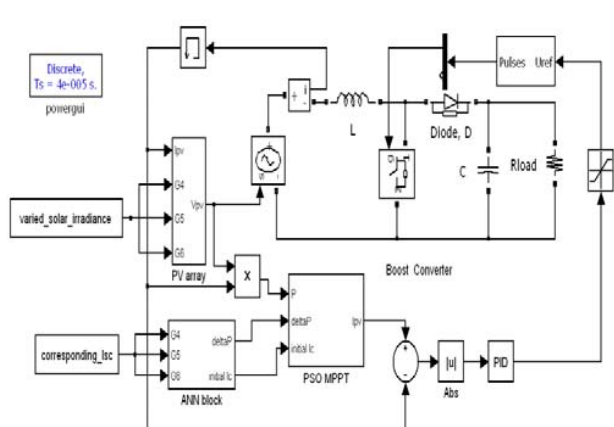

Fig. 6 The simulation blocks of the proposed multiple peaks tracking converter in MATLAB/Simulink

The PV array consists of six PV modules which were connected in series as shown Fig. 4. The PV module was modeled by using the single diode equations with by-pass diodes connected across the PV cells according to the specifications of PV module P1310x990 as shown in Table 1. The solar irradiances of the first three PV modules were fixed at  $1000 W/m^2$ . While the solar irradiances of the other three PV modules were varied for testing purpose, which the PV array under partially shaded conditions was investigated in this work. Hence, the varied solar irradiances of the three PV modules were the inputs of PV array, while the PV current was another input of the PV array. The PV array generates PV voltage,  $V_{PV}$  which acts as the controlled voltage source of the boost converter. The boost converter consists of an inductor,  $L$  of 30 mH, a capacitor,  $C$  of 3  $\mu F$ , an ideal switch and a power diode. The converter was connected to a resistive load,  $R_{load}$  of

25  $\Omega$ . The ideal switch was controlled by a pulse-width modulation (PWM) block with switching frequency,  $f_s$  of 30 kHz. The MPPT algorithm used was the hybrid of ANN and PSO algorithm.

The ANN block consists of three inputs and two outputs: the inputs were the varied solar irradiances of three PV modules, while the outputs were the difference of power generated by previous and current iteration,  $\Delta P$ , and the initial values of PV current. The outputs of the ANN block were fetched into the inputs of PSO block, the PV power generated by PV array was another input of PSO block. The PSO algorithm generated reference PV current,  $I_{PSO}$ , which was then compared to the PV current generated by PV array,  $I_{PV}$ . The difference of the reference current and the PV current generated were then enhanced by the PID controller, which was then normalized in the range of zero to one by the saturation block. This value was fetched into the PWM generator to control the switching of the ideal switch. Meanwhile, the PID constants are determined by trial and error. The discrete sample time of the simulations was 1  $\mu$ s, while the simulation time was set at 0.01 s.

## V. RESULTS AND DISCUSSIONS

Two set of simulations were performed using the simulation blocks that built in MATLAB/Simulink. The first simulation was to generate the characteristic curves of PV array under partially shaded conditions, whereby the PV array is not connected to boost converter and MPPT algorithms. For the second simulation, five cases of PV array under partially shaded condition were tested as according to configuration tabulated in Table 5. The corresponding maximum power generated by the PV array under different combinations of solar irradiance patterns are listed in Table 4.

TABLE IV  
THE SOLAR IRRADIANCE PATTERNS FOR G1 TO G6

Case	G1 to G3 (W/m <sup>2</sup> )	G4 (W/m <sup>2</sup> )	G5 (W/m <sup>2</sup> )	G6 (W/m <sup>2</sup> )	Maximum power, $P_{max}$ (W)
1	1000	1000	1000	1000	904.5
2	1000	900	900	400	704.5
3	1000	900	800	400	652.6
4	1000	700	700	400	572.6
5	1000	700	500	400	461.1

The P-V characteristics of the PV array under partially shaded conditions are shown in Fig. 7. All PV modules were exposed under full illumination for Case 1, hence, there was only one MPP generated at 904.5 W. Three PV modules were exposed under full illumination for Case 2, 3, 4 and 5, while another three PV modules were partially shaded. The P-V characteristic curves show that three peaks were established for Case 2 and 4 because the PV array was partially shaded by two different solar irradiance values. Meanwhile, four peaks were shown for Case 3 and 5 where the PV array was partially shaded by three different values of solar irradiance.

The simulations of PV array with hybrid PSO and ANN algorithm were carried out by testing the PV array with step change of solar irradiance. There were four cases for the step change simulations, which is stated in Table 5. Each case was

simulated for a duration of 0.015 s, where the time interval for each solar irradiance step change is 0.003 s.

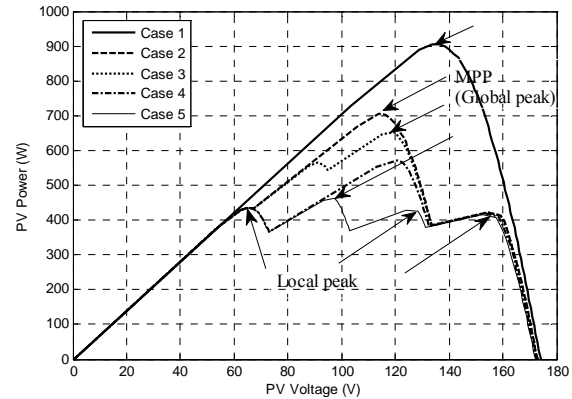

Fig. 7 The P-V characteristics of the PV array under different illumination according to the configuration stated in Table IV

TABLE V  
THE STEP CHANGE OF SOLAR IRRADIANCE FOR THE SECOND SIMULATION

Case	G4 (W/m <sup>2</sup> )	G5 (W/m <sup>2</sup> )	G6 (W/m <sup>2</sup> )
1	[1000 1000 600]	[1000 900 400]	[1000 500 200]
2	[800 1000 1000]	[400 900 1000]	[200 500 1000]
3	[800 1000 1000]	[700 1000 900]	[500 1000 500]
4	[1000 1000 600]	[900 1000 400]	[500 1000 200]

The waveforms of the PV power against the simulation time were plotted for all cases according to solar irradiance patterns in Table 5 are shown in Fig. 8. All the waveforms show different step change of solar irradiance. It can be noticed that the maximum power generated for each step change was not constant and not smooth, the ripples are always there to disturb the maximum power generated. This problem might be due to the unsuitable LC values selected for the boost converter. Even though, the boost converter is used to boost up the output voltage of the system, nevertheless the LC components are also used to filter out the ripples and noise for the system at the same time. Therefore, the design of the boost converter should be take into consideration in order for the PV system to work well with the MPPT algorithms.

Table 6 shows a more detail explanation about the waveform shown in Fig. 8. It compares the maximum power,  $P_{max}$  generated by a single PV array with the MPPT power generated when the PV array is connected to the MPPT algorithm under partially shaded condition. The values of the  $P_{max}$  generated were obtained by plotting the P-V characteristic curves as generated by PV array in Fig. 4 when solar irradiance is varied according to Table 5. The values of maximum power generated with implemented MPPT algorithm,  $P_{MPPT}$  generated were obtained from the waveforms in Fig. 8. The values are the approximation values from the waveforms. The comparison values of power generated were further analyzed by its tracking efficiency according to (4) as below.

$$\text{Tracking efficiency, } E = \frac{P_{mppt}}{P_{max}} \times 100\% \quad (4)$$

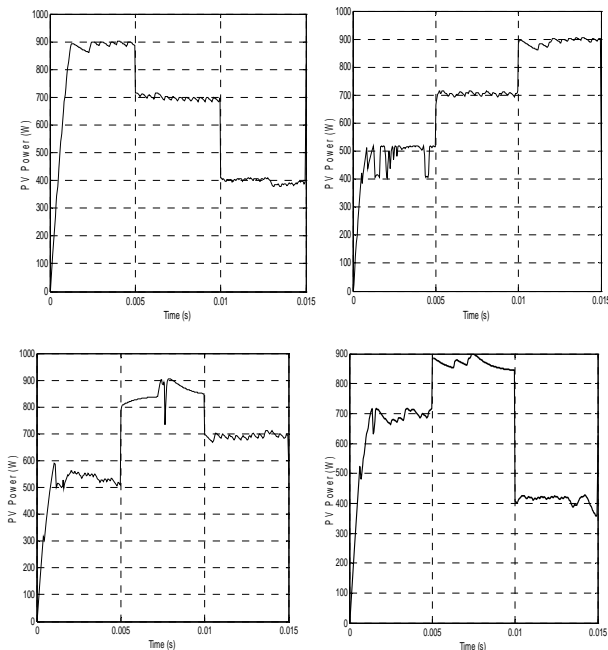

Fig. 8 The simulated waveforms of the PV power according to solar irradiance patterns stated in Table V

It can be noticed that the tracking efficiency of the hybrid PSO and ANN algorithm for each case is in the range of 91.8 % to 99.5 %.

TABLE VI  
THE COMPARISON OF MAXIMUM POWER AND MPPT POWER GENERATED FOR EACH CASE

Case	Maximum power, $P_{max}$ (W)	MPPT power, $P_{MPPT}$ (W)	Tracking efficiency, $E$ (%)
1	904.5, 715.7, 435.7	900, 700, 400	99.5, 97.8, 91.8
2	516.8, 715.7, 904.5	500, 710, 900	96.7, 99.2, 99.5
3	580.9, 904.5, 715.7	550, 880, 700	94.8, 97.3, 97.8
4	715.7, 904.5, 435.7	700, 880, 420	97.8, 97.3, 96.4

The simulation results indicated that the hybrid PSO and ANN algorithms are capable to detect the maximum power point when the PV array is under partially shaded conditions. Although the values of MPP detected are slightly different with the expected maximum powers, yet the tracking efficiency of the hybrid algorithms can reach as high as 99 %, which means that the proposed algorithm can perform well for the PV array under partially shaded conditions.

The simulations of the hybrid algorithms are time consuming because the ANN algorithm needs to learn through one hundred samples to conclude for the suitable outputs corresponding to different combinations of solar irradiance. Hence, the long simulation time is the only obvious disadvantage in this work.

In brief, the PV characteristic curves show multiple peaks of power point when the PV array was partially shaded. The proposed hybrid algorithm is capable of detecting the MPP nicely when there is a step change of solar irradiance. However, the design of the whole PV system should be further improved to obtain a better result.

## VI. CONCLUSIONS

The conventional MPPTs are incapable to detect the global peak among all the peaks the P-V characteristic curve under partial shaded conditions because once the algorithm meets a peak, it stuck within the peak and cannot rise to detect the rest of the peaks. Hence, those algorithms cannot assist the PV system to extract the maximum available PV power. By using the hybrid PSO and ANN algorithm, where the ANN was used to generate suitable values of  $\Delta P$  and initial value of PV current to the PSO algorithm when there is a change of solar irradiance. The PSO algorithm then generate the PV current at MPP for the corresponding change of solar irradiance. Therefore, the PV system can always produce maximum power due to the PV current at MPP is detected by the algorithm even under partially shaded condition. Therefore, the hotspot problem of the PV panel can be eliminated while the optimum PV energy is harvested. The proposed algorithm should be compared with other MPPT algorithms in future research so that the weakness of the algorithm might be further improved.

## REFERENCES

- [1] O. Santos, J.L., et al., A maximum power point tracker for PV systems using a high performance boost converter. *Solar Energy*, 2006. 80(7): p. 772-778.
- [2] Acciari, G., D. Graci, and A. La Scala, Higher PV Module Efficiency by a Novel CBS Bypass. *Power Electronics, IEEE Transactions on*, 2011. 26(5): p. 1333-1336.
- [3] Young-Hyok, J., et al., A Real Maximum Power Point Tracking Method for Mismatching Compensation in PV Array Under Partially Shaded Conditions. *Power Electronics, IEEE Transactions on*, 2011. 26(4): p. 1001-1009.
- [4] Ben Salah, C. and M. Ouali, Comparison of fuzzy logic and neural network in maximum power point tracker for PV systems. *Electric Power Systems Research*, 2011. 81(1): p. 43-50.
- [5] ESRAM, T. and P.L. Chapman, Comparison of Photovoltaic Array Maximum Power Point Tracking Techniques. *Energy Conversion, IEEE Transactions on*, 2007. 22(2): p. 439-449.
- [6] Salas, V., et al., Review of the maximum power point tracking algorithms for stand-alone photovoltaic systems. *Solar Energy Materials and Solar Cells*, 2006. 90(11): p. 1555-1578.
- [7] Femia, N., et al., Optimization of perturb and observe maximum power point tracking method. *Power Electronics, IEEE Transactions on*, 2005. 20(4): p. 963-973.
- [8] Fangrui, L., et al., A Variable Step Size INC MPPT Method for PV Systems. *Industrial Electronics, IEEE Transactions on*, 2008. 55(7): p. 2622-2628.
- [9] Carannante, G., et al., Experimental Performance of MPPT Algorithm for Photovoltaic Sources Subject to Inhomogeneous Insolation. *Industrial Electronics, IEEE Transactions on*, 2009. 56(11): p. 4374-4380.
- [10] S. Silvestre, a.A.C., Effects of Shadowing on Photovoltaic Module Performance. *Prog. Photovolt: Res. Appl.*, 2008. 16: p. 141-149.
- [11] Ghoddami, H. and A. Yazdani, A Single-Stage Three-Phase Photovoltaic System With Enhanced Maximum Power Point Tracking Capability and Increased Power Rating. *Power Delivery, IEEE Transactions on*, 2011. 26(2): p. 1017-1029.
- [12] R.Ramaprabha, D.B.L.M., Impact of Partial Shading on Solar PV Module Containing Series Connected Cells. *International Journal of Recent Trends in Engineering*, 2009. Vol. 2(No. 7): p. 56-60.
- [13] Giraud, F. and Z.M. Salameh, Analysis of the effects of a passing cloud on a grid-interactive photovoltaic system with battery storage using neural networks. *Energy Conversion, IEEE Transactions on*, 1999. 14(4): p. 1572-1577.
- [14] Hsu, Y.-J.W.P.-C., Analytical modelling of partial shading and different orientation of photovoltaic modules. *IET Renew. Power Gener.*, 2010. Vol. 4(Iss. 3): p. 272-282.
- [15] Patel, H. and V. Agarwal, Investigations into the performance of photovoltaics-based active filter configurations and their control

- schemes under uniform and non-uniform radiation conditions. Renewable Power Generation, IET, 2010. 4(1): p. 12-22.
- [16] Agarwal, H.P.a.V., MATLAB-Based Modeling to Study the Effects of Partial Shading on PV Array Characteristics. IEEE TRANSACTIONS ON ENERGY CONVERSION, VOL. 23, NO. 1, MARCH 2008, 2008. Vol. 23(No. 1): p. 302-310.
- [17] MASAFUMI MIYATAKE, M.V., FUHITO TORIUMI, NOBUHIKO FUJII, HIDEYOSHI KO, Maximum Power Point Tracking of Multiple Photovoltaic Arrays: A PSO Approach. IEEE TRANSACTIONS ON AEROSPACE AND ELECTRONIC SYSTEMS, 2011. Vol 47(No. 1).
- [18] Phimmason, V.K., Y.; Kamejima, T.; Miyatake, M.; , Evaluation of extracted energy from PV with PSO-based MPPT against various types of solar irradiation changes 2010 International Conference on Electrical Machines and Systems (ICEMS), 2010: p. 487-492.
- [19] Low, T.L.N.a.K.-S., A Global Maximum Power Point Tracking Scheme Employing DIRECT Search Algorithm for Photovoltaic Systems IEEE TRANSACTIONS ON INDUSTRIAL ELECTRONICS, 2010. Vol. 57(No. 10): p. 3456-3467.
- [20] Engin Karatepe, T.H., Mutlu Boztepe, Metin C, olak Voltage based power compensation system for photovoltaic generation system under partially shaded insolation conditions. Energy Conversion and Management, 2008. 49: p. 2307-2316.
- [21] Agarwal, H.P.a.V., Maximum Power Point Tracking Scheme for PV Systems Operating Under Partially Shaded Conditions. IEEE TRANSACTIONS ON INDUSTRIAL ELECTRONICS, VOL. 55, NO. 4, APRIL 2008, 2008. Vol. 55(No. 4): p. 1689-1698.
- [22] Bai, Q., Analysis of Particle Swarm Optimization Algorithm. Computer and Information Science, 2010. 3(1): p. 180-184.
- [23] Wijnings, P., Training neural networks with particle swarm optimization. March 12, 2011. p. 60.
- [24] Daniel Merkle, M.M., Swarm Intelligence, in Book Chapter 14. p. 37.
- [25] Ze Cheng, H.Z., Hongzhi Yang, Research on MPPT control of PV system based on PSO algorithm. Control and Decision Conference (CCDC), 2010 Chinese, 2010: p. 887-892.
- [26] Larsen, J., Introduction to Artificial Neural Network. Book chapter, 1st ed. 1999.
- [27] Phan Quoc, D., et al. The new MPPT algorithm using ANN-based PV. in Strategic Technology (IFOST), 2010 International Forum on. 2010.
- [28] C.-C. YANG, S.O.P., J.-A. LANDRY, H.S. RAMASWAMY and A. DITOMMASO, Application of artificial neural networks in image recognition and classification of crop and weeds. Canadian Agricultural Engineering 2000. 42(3): p. 147-152.
- [29] PremChand Kumar, E.W., Cash Forecasting: An Application of Artificial Neural Networks in Finance. International Journal of Computer Science & Applications, 2006. III(1): p. 61-67.
- [30] Haykin, S., Feedforward Neural Network: An Introduction. Book chapter, p. 1-16.