

Multi-Criteria Optimization of High-Temperature Reversed Starter-Generator

Flur R. Ismagilov, Irek Kh. Khayrullin, Vyacheslav E. Vavilov, Ruslan D. Karimov, Anton S. Gorbunov, Danis R. Farrakhov

Abstract—The paper presents another structural scheme of high-temperature starter-generator with external rotor to be installed on High Pressure Shaft (HPS) of aircraft engines (AE) to implement More Electrical Engine concept. The basic materials to make this starter-generator (SG) were selected and justified. Multi-criteria optimization of the developed structural scheme was performed using a genetic algorithm and Pareto method. The optimum (in Pareto terms) active length and thickness of permanent magnets of SG were selected as a result of the optimization. Using the dimensions obtained, allowed to reduce the weight of the designed SG by 10 kg relative to a base option at constant thermal loads. Multidisciplinary computer simulation was performed on the basis of the optimum geometric dimensions, which proved performance efficiency of the design. We further plan to make a full-scale sample of SG of HPS and publish the results of its experimental research.

Keywords—High-temperature starter-generator, More electrical engine, multi-criteria optimization, permanent magnet.

I. INTRODUCTION

ONE of the main tasks of modern aircraft construction is to improve environmental performance, handleability and fuel efficiency of the AE. To solve this problem, global producers of AE, such as Rolls-Royce, United Engine Corporation and PW Canada are actively working to increase AE electrification and making More Electrical Aircraft Engine (MEE) [1], [2].

The main conceptual solution for implementation of MEE is elimination of the Auxiliary Gear-Box (AGB) between the AE shaft and the electric machine. That is, the electric machine is installed directly in AE on the HPS. This makes it possible to achieve significant economic and technical effect both for AE and for the entire aircraft. Integration of the electric machine on the HPS of AE has the following benefits:

- Greatly simplified AE maintenance [1];
- Reduces mass and dimensions AE parameters (by eliminating AGB, AE mass can be reduced by 15 – 20%) [3];
- Enhanced AE fuel efficiency [3];
- Direct electrical start of AE is provided [4]. For electric

F. R. Ismagilov is with the Electromechanics Department, Ufa State Aviation Technical University, Ufa, Russia (corresponding author; phone: +7-347-273-77-87; e-mail: ifr@ugatu.ac.ru).

I. Kh. Khayrullin, V. E. Vavilov, R. D. Karimov, A. S. Gorbunov, and D. R. Farrakhov are with the Electromechanics Department, Ufa State Aviation Technical University, Ufa, Russia (e-mail: s2_88@mail.ru, s2_88@mail.ru, ruslan-k88@yandex.ru, freizer-anton@yandex.ru, d.farrakhov@yandex.ru).

The study was performed due to the grant from the Russian Science Foundation (Project № 16–19–10005).

start of AE, the electric machine must have a SG.

Fig. 1 shows the current design of AE and SG and prospective design of AE and SG using the MEA concept.

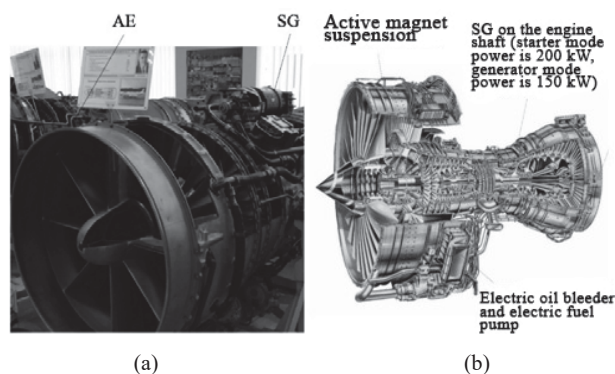

Fig. 1 Modern design of AE and SG (a) and prospective design of MEA (b)

The main difficulties in installing SG on HPS are the temperature conditions of the HPS environment, as well as a high degree of SG integration in AE, that is, when SG is installed on HPS, SG shall be operated as a single system with AE, while an emergency situation in SG becomes the cause of an emergency situation in AE. To avoid emergency situations in AE, SG shall be of improved safety. Therefore, in addition to the requirements for conventional aircraft SG, individual requirements are imposed on SG installed on HPS to ensure temperature resistance and safety. Then the general requirements applicable to SG installed on HPS can be as follows:

- Reliable operation at ambient temperatures of 300–330 °C and pressure up to 5 bar;
- Maximum efficiency (over 90%);
- Minimum weight and size parameters;
- High strength under mechanical, thermal and electromagnetic loads and overloads, operation at high vibrations;
- Self-excitation;
- The quality of electric power generated by SG in generator mode, when working as part of the generating channel must comply with the requirements of MIL STD 704IE;
- In case of an emergency in SG, the emergency situation shall be localized in it and shall not affect the processes in AE.

To make SG in accordance with the above requirements,

various researchers suggest different SG designs. University of Sheffield develops SG integrated into AE (High temperature embedded electrical machines) on the basis of inductor electrical machine [2], [5] (to the benefit of Rolls-Royce). Moreover, all scientific papers related to their development are closed by their industrial partner (including the thesis of Leon Rodrigues on this subject). This limits discussion of their achievements in this field and does not allow comparison with the technical solutions and ideas of other researchers. At the same time, it is known from the general theory of electric machines that inductor SG have high weight and size parameters, therefore their use as SG installed on HPS is probably less effective than using SG with permanent magnets.

Thales AES develops SG to be installed on HPS based on the electrical machine with high-coercivity permanent magnets [1]. SG from Thales is designed for power of 150 kW in generator mode at rotation frequency of 9,000 rev/min; in starter mode it provides a moment of 350 Nm at rotation frequency of 4,800 rev/min. SG is oil-cooled and has a back-up coil. The stator and rotor mass of this SG is 88 kg [1].

Complexity of SG oil cooling in AE, as well as considerable weight and mass parameters of this SG reduce the efficiency of its use in AE. Therefore, we have proposed a concept of using the electrical machine with permanent magnets and the external rotor and the magnetic system based on Halbach array as SG for installation on HPS [6], [7]. Halbach array is used because the rotor back is made of titanium and is part of AE. The advantage of this design is that the external rotor is cooled by outboard air. This will ensure acceptable operating temperature (up to 330 °C) for permanent magnets (such T 550 magnets with the maximum operating temperature of not more than 550 °C). The studies of the thermal state of such SG are given in papers of A. Cavagnino [8]–[11], as well as the processes of control of similar electrical machines.

II. STATEMENT OF THE RESEARCH PROBLEM

To evaluate the efficiency of the proposed technical solution, the authors calculated SG with external and internal rotor for installation on HPS. Calculations were performed using ANSYS Maxwell software package taking into account the SG ambient temperature and the decline of energy characteristics of the permanent magnets. T 550 HCPMs are used in SG of HPS. Their operating temperature is 550 °C, and the residual induction is 0.96 T [12]. Based on the data [1], the SG ambient temperature was assumed to be 300 °C. The temperature of HCPM of SG with external rotor was 330 °C (taking into account the external rotor air cooling) [8]–[11], and the temperature of HCPM with the internal rotor due to the absence of HCPM cooling was 360 °C. The winding of SG of HPS is made of heat-resistant nickel wire «ТЮЖ-700», insulation is of fiberglass impregnated with heat-resistant composition and having an additional lacquer layer, operating temperature is up to 700 °C. SG stator is made of Vacodur S+, which retains its electromagnetic properties at a temperature up to 800 °C [13]. The change in energy characteristics of

HCPM depending on the temperature in the calculations was taken into account by the known expressions [14]. To maximize SG survivability, it was assumed in the calculations that it uses two independent three-phase windings (each laid in its slot), Fig. 2. This provides a thermal and galvanic isolation of both windings and greatly increases SG reliability. As shown in [15], simultaneous failure of both independent windings of SG is an unlikely event. In calculations, the geometry was taken based on the data [1]: the outer diameter of the active part of 300 mm, the active length of 150 mm. It should be noted that SG with the external rotor design has a larger non-magnetic gap, caused by the rotor bandage with a thickness of 4 mm. Calculation results are given in Table I.

TABLE I
RESULTS OF CALCULATIONS OF HIGH-TEMPERATURE SG THAT CAN BE
INTEGRATED INTO HPS OF AE

	SG with external rotor	SG with internal rotor
Power in regenerator mode, kW	150	150
Rotor speed, rev/min	9000	9000
The number of poles	8	8
The number of phases	3x2	3x2
The number of teeth	48	48
Rated current, A	474	476
Rated voltage, V	200	200
Current density, A/mm ²	2	3,74
Linear current load, A/m	27000	67000
Rotor moment of inertia, kg*m ²	0,84	0,137
Mechanical time constant, s	2,84	0,42
Inductive resistance along d/q axes, Ohm	0,11/0,11	0,16/0,16
Magnetic induction in the air gap, T	0,45	0,3
Magnetic induction in the stator teeth, T.	1,1	1,44
Magnetic induction in the back, T	0,43	1,45
Rotor outer diameter, mm	300	186
Stator outer diameter, mm	260	300
Nonmagnetic gap, mm	3	6
Copper loss, W	525	1958
Weight of active elements of SG, kg	75	82
Relative short-circuit current	2,3	1,2

Table I shows that high-temperature SG with external rotor design as compared to SG with internal rotor has lower weight and size parameters (by 10%), has lower current density and linear current load. Their values (2.84 A/mm² and 25,000 A/m) ensure its reliable operation with self-ventilation (a heat factor of SG with external rotor is 710 A/mm² A/cm, it corresponds to aviation electrical self-ventilated machines, and SG with internal rotor has a heat factor of 2505 A/mm² A/cm, it corresponds to the limit values of electric self-ventilated machines. In this case, as seen from the results of the calculations, a disadvantage of SG with external rotor is its high inertia and high mechanical time constant. This does not allow for instant stop of the SG in emergency modes, as well as significantly increasing the time of SG to reach the rated speed in generator mode. These calculations show that for these temperature conditions and power, SG with HCPM with external rotor has higher efficiency when installed on HPS.

Calculated characteristics and dimensions of SG with

HCPM with reversed rotor, despite being better as compared with the results of Thales, are obviously not optimal. Therefore, our aim was multi-criteria optimization of dimensions of high-temperature SG with HCPM with external rotor to be installed on HPS of AE, as well as to determine the minimum weight and size parameters of SG based on the optimization results, taking into account environmental conditions and the above specifications. That is the studied electric machine must have a minimum weight at a given power (for generator mode of SG operation) and a specified torque (for motor mode), as well as minimal losses. These requirements are contradictory, thus the problem is multi-criteria, modern and is solved for the first time for SG of HPS. The urgency of this problem lies in the fact that obtaining the optimal dimensions will allow making a truly effective SG to implement More Electrical Engine (MEE), and, therefore, achieve new results for the aviation industry as a whole. In addition, the results of multi-criteria optimization will allow making SG with external rotor to be installed on HPS of AE with minimum weight, which is very important for the aerospace industry.

III. OPTIMIZATION METHOD

In solving this problem, the analytical formulation of the objective function with its subsequent derivation and study causes complexities and will lead to a significant reduction in solution accuracy. Therefore, while solving this problem, the authors have selected a method of numerical optimization based on the use of genetic algorithm (GA), which effectively proved itself in various branches of science, such as crystallography, engine-building, chemistry [16]-[18]. The advantages of GA include the opportunity to work simultaneously with several variable parameters, as well as no need to derive the objective function, and, consequently, no need to specify it in a strict analytic form. Therefore, GA are also being introduced, and show their efficiency in electrical engineering. Thus, the problem of choosing the optimal induction motor sizes from a small set of parameters using GA is solved in [19], where the optimality criterion in this case is the cost of the induction motor. The numerical optimization of induction motor sizes with incorporated permanent magnets using GA is considered in [20]. In [21], the problem of optimizing the shape of EMEC pole using GA is solved. The optimization of induction motor parameters using GA is considered in [22]. Induction motor parameters due to GA are determined in [23], where the maximum torque is the optimality criterion. The way of optimizing the electrical machine dimensions using GA, implemented in Ansoft Maxwell software package is of interest [24]. As can be seen, the problem of multi-criteria optimization of dimensions of high-temperature SG with HCPM with external rotor to be installed on HPS of AE and definition of limit minimal weight and dimensions of SG using GA was not solved, what also proves its relevancy.

Numerical optimization using GA was performed using Ansoft Maxwell software package and MATLAB algorithms. We have considered SG with permanent properties of

materials (T550 permanent magnets, «ИОЖ 700» wire, stator magnetic core of Vacodur S+) and permanent design, as shown in Fig. 2. Two independent three-phase windings were used in the considered design. The following dimensions were changed in optimization: outer and inner stator diameter, air gap, HCPM thickness and active length. All other dimensions remained permanent, as shown in Table I. The range of variant parameters was selected as follows: active length from 50 mm to 250 mm; magnet height from 6 mm to 15 mm; air gap from 1 mm to 6 mm; outer stator diameter from 258 mm to 264 mm; inner stator diameter from 0 mm to 220 mm.

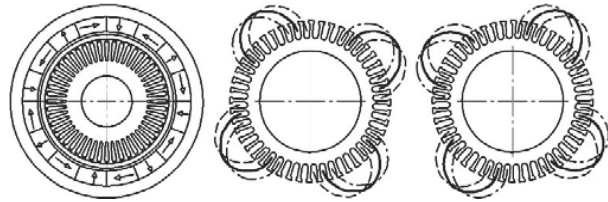

Fig. 2 The optimized SG of HPS and connection diagram of its two independent three-phase windings

In optimization of SG using GA, initial population consisted of 30 samples. Parents were selected by panmixia. Crossover was performed by roulette method. We studied three SG fitness functions (three criteria): ratio of power to total SG weight multiplied by power factor ($P \cdot pf/M \rightarrow \max$); ratio of power loss to total SG weight ($P_{loss}/M \rightarrow \min$); since the electrical machine considered is SG, it is also important for it at the minimum weight to provide maximum torque in motor mode ($m/M \rightarrow \max$). Each fitness function was considered independently. A set of optimal sizes for each criterion was obtained as a result of optimization using GA. The number of iterations for each criterion did not exceed 600, and the running time for each criterion did not exceed three hours. Then the independent sets were studied together using Pareto method.

IV. OPTIMIZATION RESULTS

A set of optimal sizes for each criterion was obtained as a result of optimization using GA. Fig. 3 shows the change in ratio of power loss to the total SG weight (P_{loss}/M) depending on iterations. Fig. 4 shows the change of ratio of power to the total SG weight multiplied by the power factor ($P \cdot pf/M$), Fig. 5 shows a change in m/M ratio. It should be noted that the calculations of starter mode were made were performed for SG at 80 °C, as starter start is performed on “cold” AE.

Analysis of the results, shown in Figs. 3–5, showed that for almost all the three criteria, the optimum is the stator outer diameter of 261.5 mm, air gap of 2.25 mm, the stator inner diameter of 60 mm. In this case active SG length and height of HCPM change: for criteria m/M , $P \cdot pf/M$, the optimum is active SG length in the range of 75-80 mm and height of HCPM of 11-12 mm, and for criterion P_{loss}/M , the optimum

is the length in the range of 190–195 mm and height of HCPM in the range of 8–9.5 mm. That is, the volume of permanent magnets changes.

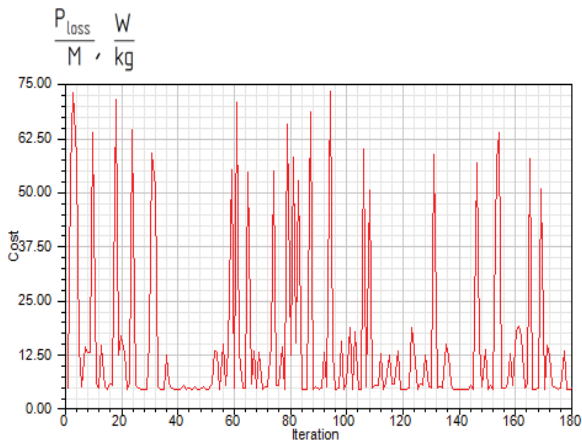

Fig. 3 Results of optimization of SG of HPS using GA for criterion $P_{loss}/M \rightarrow \min$

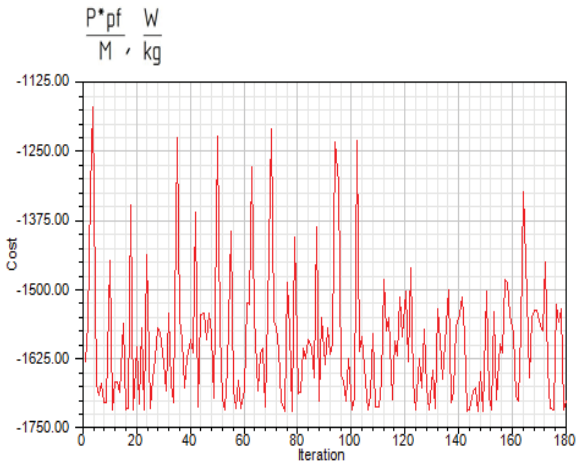

Fig. 4 Results of optimization of the height of HCPM of SG rotor using GA for criterion $P \cdot pf/M \rightarrow \max$

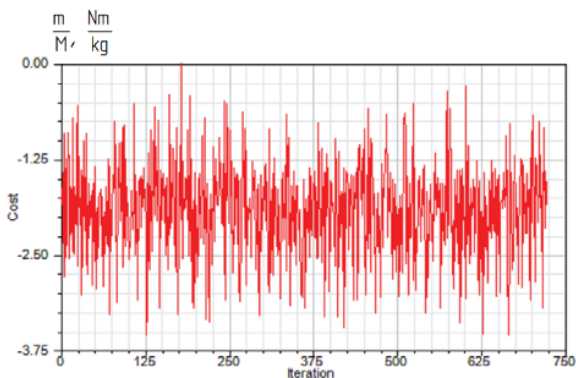

Fig. 5 Results of optimization of SG of HPS using GA for criterion $m/M \rightarrow \max$

Thus, subsequently solving the problem of multi-criteria optimization, we have considered SG not with four variable parameters, but with two of them: the active length and height of HCPM. In addition, the optimization results for criteria m/M , $P \cdot pf/M$ are virtually identical, allowing to choose only one of these criteria for multi-criteria optimization. In this case, the complete problem of multi-criteria optimization consisted in finding the optimum SG length and height of HCPM for criteria $P \cdot pf/M$ and P_{loss}/M . To solve this problem, the numerical values of the criteria studied were given in dimensionless form:

$$P_{loss}^* = \frac{P_{loss}}{M} \frac{M_{150}}{P_{loss150}}; \tag{1}$$

$$P^* = \frac{P \cdot pf}{M} \frac{M_{150}}{P_{150} \cdot pf_{150}}, \tag{2}$$

where $P_{loss150}$ – power loss at the active length of 150 mm (base case, Table I); M_{150} – SG weight at the active length of 150 mm (base case, Table I); pf_{150} – SG power factor at the active length of 150 mm (base case, Table I); P_{150} – SG full power at the length of 150 mm.

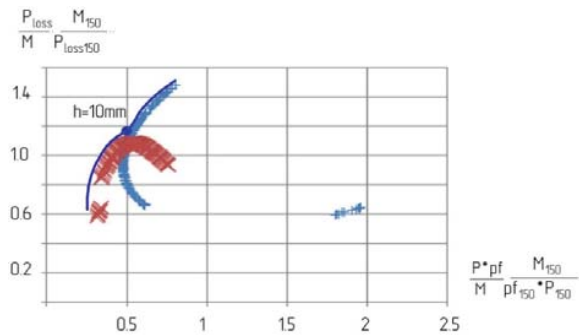

Fig. 6 Pareto front for HCPM height

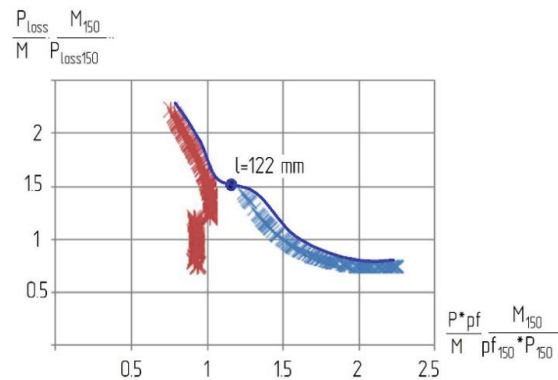

Fig. 7 Pareto front for the active SG length

Multi-criteria optimization was performed by Pareto method for each criterion; one criterion was permanent and the

other varied.

Fig. 6 shows the results of multi-criteria optimization according to Pareto for the height of SG permanent magnet, and Fig. 7 show the results for the active SG length.

The analysis of the results shows that the optimum active SG length is 122 mm and magnet height – 10 mm in terms of Pareto for the given SG of HPS with external rotor and air cooling. Thus, using a GA and the Pareto method, the optimum dimensions of the high-temperature SG to be installed on HPS of AE were determined.

To assess the efficiency of the solution, Table II gives a comparison of the original option, an option proposed by Thales and the optimized option. Thus, as a result of using a

multi-criteria optimization using GA, the high-temperature SG was calculated to be installed on HPS, weighing 17 kg less than industrially produced electrical machine, and 10 kg less than the base case. In this case the thermal loads (current density, copper loss, linear current load and heat factor) remained almost unchanged (current density – by 0.3 A/mm², while the linear current load has been reduced to 2000 A/m). That is, multi-criteria optimization using GA and the Pareto method yielded SG almost equivalent to the base case in terms of thermal and electromagnetic loads, but weighs 10 kg less than SG of the base case. This result proves the efficiency of the optimization method used, and proves feasibility of its implementation.

TABLE II
RESULTS OF CALCULATIONS OF HIGH-TEMPERATURE SG THAT CAN BE INTEGRATED INTO HPS OF AE

	SG with external rotor (optimum option)	SG with external rotor	SG with internal rotor	SG with external rotor (optimum option)
Power in regenerator mode, kW	150	150	150	150
Rotor speed, rev/min	9000	9000	9000	9000
The number of poles	8	8	8	8
The number of phases	3x2	3x2	3x2	3x2
The number of teeth	48	48	48	48
Rated current, A	440	474	476	440
Rated voltage, V	200	200	200	200
Current density, A/mm ²	2.3	2	3.74	2.3
Linear current load, A/m	25000	27000	67000	25000
Rotor moment of inertia, kg*m ²	0.84	0.84	0.137	0.84
Mechanical time constant, s	2.84	2.84	0.42	2.84
Inductive resistance along d/q axes, Ohm	0.09/0.09	0.11/0.11	0.16/0.16	0.09/0.09
Magnetic induction in the air gap, T	0.54	0.45	0.3	0.54
Magnetic induction in the stator teeth, T.	1.7	1.7	1.44	1.7
Magnetic induction in the back, T	0.45	0.43	1.45	0.45
Rotor outer diameter, mm	300	300	186	300
Stator outer diameter, mm	261.5	260	300	261.5
Nonmagnetic gap, mm	2.25	3	6	2.25
Copper loss, W	524	525	1958	524
Weight of active elements of SG, kg	65	75	82	65
Relative short-circuit current	2.29	2.3	1.2	2.29

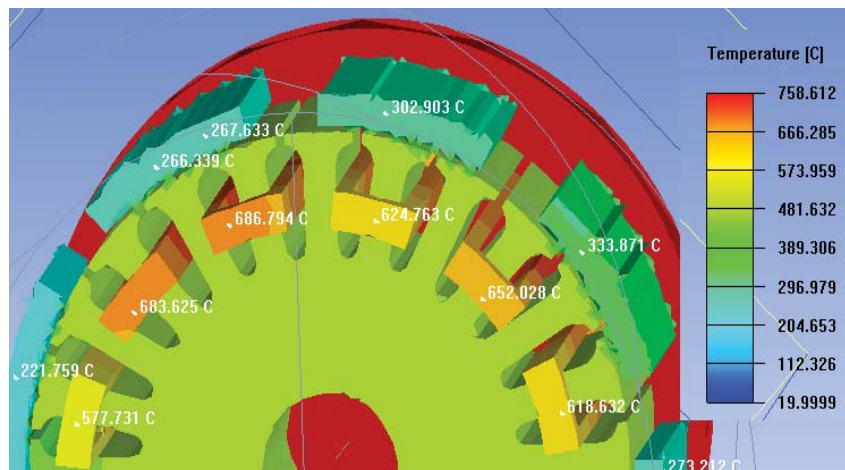

Fig. 8 Results of computer modeling of the thermal state of SG of HPS

V. COMPUTER MODELING OF THE OPTIMIZED HIGH-TEMPERATURE SG

Multidisciplinary computer simulation of SG of HPS was conducted to assess performance of the optimized SG (thermal modeling in Ansys software package, electromagnetic modeling (magnetic field at idle and under load was studied) in Ansys Maxwell software package). Simulation modeling of starter electric starting was performed in the MATLAB Simulink software package to assess performance of the developed SG in starter mode. The computer modeling results are given below.

Fig. 8 shows the results of computer modeling of the thermal state of SG of HPS obtained in Ansys software package. For modeling, it was assumed that external rotor is blown by air at 100-150 °C, air flow is 30 l/s. Also it was taken into account that air flow cooling SG is turbulent.

The results of computer modeling of the thermal state show that the maximum magnet temperature does not exceed 330 °C (does not differ from that adopted in optimization), maximum winding temperature is 650 °C (maximum operating temperature of the wire used is 700 °C). Thus, the thermal modeling results confirm performance of the optimized SG of HPS.

Taking into account the above temperatures of active SG elements and dimensions, a computer model was developed in Ansys Maxwell software package, and magnetic field were studied, as well as the characteristics of high-temperature SG of HPS in dynamics. Computer modeling results are shown in Figs. 9 and 10.

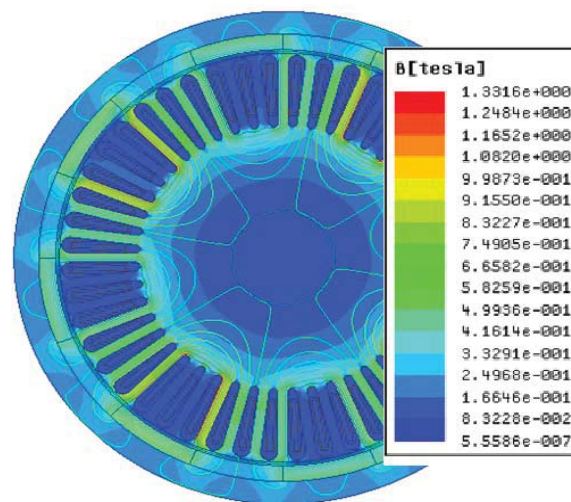

Fig. 9 Distribution of the magnetic field in high-temperature SG of HPS at 0 sec (the design with reversed rotor with a Halbach magnetic assembly, rotor back of titanium, permanent magnets are glued on titanium back; this SG has two three-phase windings, each located in its grooves; the modeling was conducted taking into account heating of the active elements of SG of HPS, Fig. 8)

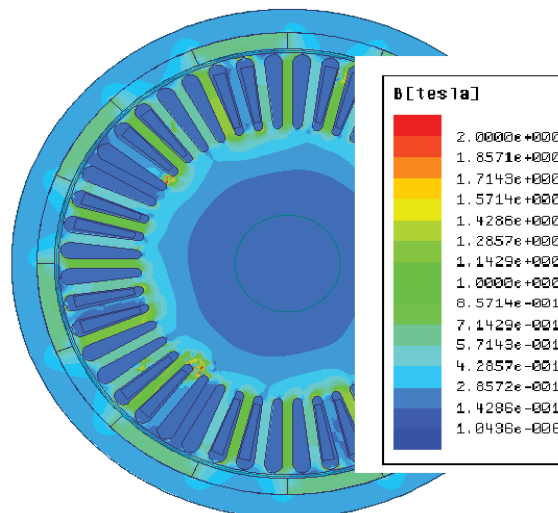

Fig. 10 Magnetic field distribution in high-temperature SG of HPS at 0.005 seconds

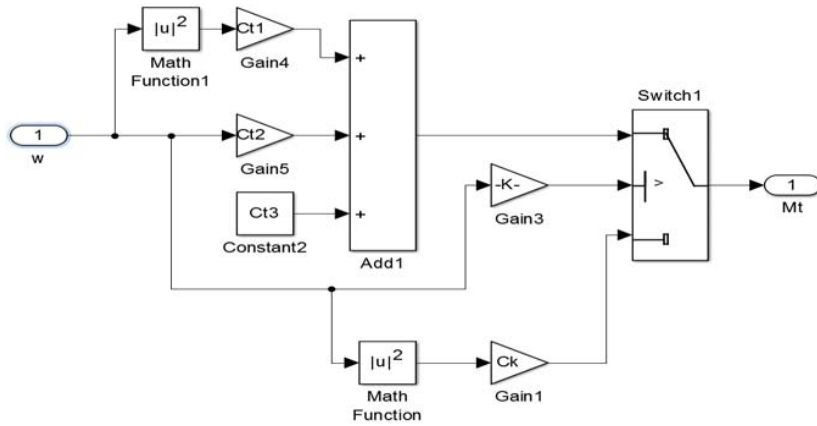

Fig. 13 Turbine item simulates the work of GTE turbine

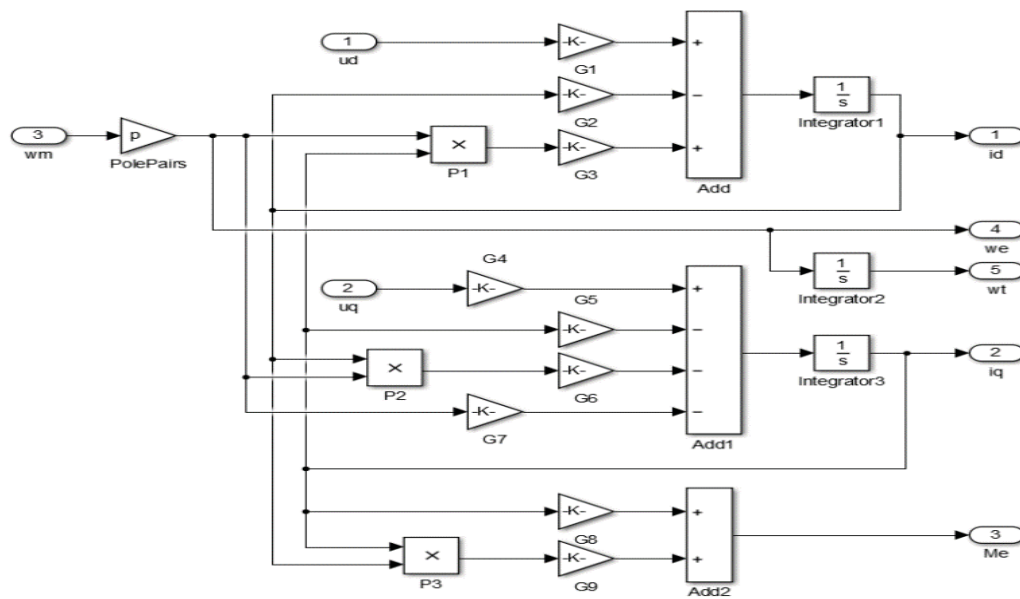

Fig. 14 Generator model, PMSM item

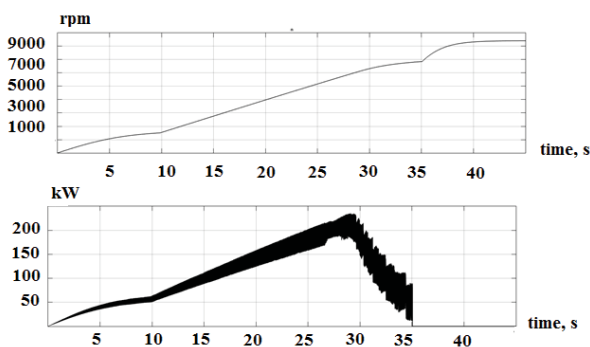

Fig. 15 Rotation frequency and mechanical power on the SG shaft

The *VSI* item simulates control system and power supply of the frequency converter and includes rotation frequency feedback loop, proportional current regulator, coordinate conversion units and hysteretic current regulator.

Change in the SG rotation frequency and mechanical power during engine electric start, resulted from modeling, is shown in Fig. 15.

As follows from the above charts, in short-term one-and-a-half-fold overload, the SG with the above parameters and vector control ensures a reliable start-up of aircraft propulsion engine; the total start-up time is 55 seconds. Thus, computer modeling results confirm performance and proper choice of the dimensions of high-temperature SG.

VI. CONCLUSION

The article describes the study of possible reliable operation of high-temperature SG based on HPS of AE at ambient temperatures up to 330 °C and a pressure of 5 bar. We have considered the existing SG design schemes and found their strengths and weaknesses during analysis. In addition, the authors proposed implementation of their own structural scheme of SG with external rotor. Calculations were

performed to evaluate efficiency of the proposed solution, and their results showed better performance compared to the results of Thales.

To further improve SG parameters, we have conducted multi-criteria optimization of the structural scheme developed using a GA and Pareto method. The optimization allowed to find the optimal dimensions of high-temperature SG to reduce the weight by 10 kg relative to a base option at constant thermal loads.

The resulting structural scheme built after optimization has proved its performance and efficiency based on computer modeling data.

ACKNOWLEDGMENT

The study was performed due to the grant from the Russian Science Foundation (Project № 16–19–10005).

REFERENCES

- [1] J.-P. I. Besnard, F. Biaisi, and M. Martinez, "Electrical rotating machines and power electronics for new aircraft equipment systems," in *ICAS-Secretariat - 25th Congress of the International Council of the Aeronautical Sciences*, 2006.
- [2] J. Wang, and D. Howe, "Advanced electrical machines for new and emerging applications," in *Nordic Seminar on 'Advanced Magnetic Materials and their Applications'*, 10th/11th October 2007, Pori, Finland, 2007.
- [3] A.V. Levin, "Starter-generator system with an electric machinery assembly built in the aircraft engine for fully electrified aircraft," *Aviation industry*, № 1. pp. 50-52, 2007.
- [4] M. Van Der Geest, H. Polinder, J.A. Ferreira, and D. Zeilstra, "Machine selection and initial design of an aerospace starter/generator," in *2013 IEEE International Electric Machines and Drives Conference IEMDC 2013, 12 May 2013 through 15 May 2013, Code 98445*, Chicago, IL; United States, 2013.
- [5] Leon Rodrigues, *High temperature embedded electrical machines for aerospace turbine applications*. PhD thesis, University of Sheffield. 2013.
- [6] F.R. Ismagilov, I.Kh. Khayrullin, V.E. Vavilov, A.M. Yakupov, and V.I. Bekuzin, "High-temperature, open-frame starter-generator integrated in the aircraft engine," *Bulletins of the universities. Aircraft engineering*, №1, 2016.
- [7] F.R. Ismagilov, I.Kh. Khayrullin, V.E. Vavilov, and R.D. Karimov, "High-temperature electromechanical energy converters that can be integrated into the aircraft engine. Prospects and challenges of creating," *Aerospace instrumentation technology*, № 9, 2015, pp. 48-56.
- [8] A. Cavagnino, Z. Li, A. Tenconi, and S. Vaschetto, "Integrated generator for more electric engine: Design and testing of a scaled-size prototype." *IEEE Transactions on Industry Applications*, vol. 49, issue 5, 2013, pp. 2034–2043.
- [9] A. Boglietti, A. Cavagnino, D.A. Staton, and M. Popescu, "Experimental assessment of end region cooling arrangements in induction motor endwindings," *IET Electric Power Applications*, vol. 5, issue 2, 2011, pp. 203–209.
- [10] M. Tosetti, P. Maggiore, A. Cavagnino, and S. Vaschetto, "Conjugate heat transfer analysis of integrated brushless generators for more electric engines," in *5th Annual IEEE Energy Conversion Congress and Exhibition. ECCE 2013, 15 September 2013 through 19 September, 2013*, Denver, CO, United States, 2013, pp. 1518–1525.
- [11] R. Bojoi, A. Cavagnino, A. Tenconi, and S. Vaschetto, "Control of shaft-line-embedded multiphase starter/generator for aero-engine," *IEEE Transactions on Industrial Electronics*, 2016, pp. 641–652.
- [12] Jinfang Liu, Heeju Choi, Alan Palazzolo, Randall Tucker, Andrew Kenny, Kyung-Dae Kang, Varun Ghandi, and Andrew Provenza, "High Temperature Hybrid Radial Magnetic Bearing Systems Capable of Operating up to 538°C (1000°F)," in *Proceedings of 20th International Workshop on Rare Earth Permanent Magnets and Their Applications, Sept. 8-10, 2008*, Crete, Greece, 2008.
- [13] Leon K. Rodrigues, and Geraint W. Jewel, "Model Specific Characterization of Soft Magnetic Materials for Core Loss Prediction in Electrical Machines," *IEEE Transactions on Magnetics*, vol. 50, issue 11.
- [14] "Temperature Effects on Magnet Output," *Arnold the magnetic product group of. TN0303. 06.2003. 4 P.*
- [15] E.V. Volokitina, V.I. Kovyazin, A.I. Vlasov, and N.V. Nikitin, "Autonomous power supply system of automatic aircraft engine control" *Power supply and electrical equipment of vehicles*, № 3, 2015, pp. 14-20.
- [16] A.R. Oganov, and C.W. Glass, "Evolutionary crystal structure prediction as a tool in materials design" *Journal of Physics: Condensed Matter*, vol. 20, № 6.
- [17] A.I. Belousov, and A.Y. Sapozhnikov, "Synthesis of basic structural design of aircraft GTE based on genetic algorithms," *Russian Aeronautics*, 2015.
- [18] A.R. Oganov, and M. Valle, "How to Quantify Energy Landscapes of Solids," *Journal of Chemical Physics*, vol. 130, № 10, 2009, p. 104.
- [19] A. Krishnamoorthy, and K. Dharmalingam, "Application of Genetic Algorithms in The Design Optimization of Three Phase Induction Motor," *Journal of Computer Applications*, vol. II, № 4, 2009.
- [20] Stjepan Stipetic, Werner Miebach, and Damir Zarko, "Optimization in Design of Electric Machines: Methodology and Workflow," in *2015 ACEMP - OPTIM - ELECTROMOTION joint conference*, 2015.
- [21] G.F. Uler, O.A. Mohammed, and Chang-Seop Koh, "Design optimization of electrical machines using genetic algorithms" *IEEE Transactions on Magnetics*, vol. 31, issue 3.
- [22] D.H. Cho, H.K. Jung and C.G. Lee, "Induction Motor Design for Electric Vehicle Using A Niching Genetic Algorithm," *IEEE*, 1999.
- [23] Pragasen Pillay, and Ray Nolan, "Application of Genetic Algorithms to Motor Parameter Determination for Transient Torque Calculations," *IEEE Transactions On Industry Applications*, vol. 33, №. 5, 1997, pp. 1273–1282.
- [24] Yao Duan and M. Dan, "New Method for Electrical Machine Design and Optimization," in *ANSYS User Conference, September 2011*, 2011.



Flur R. Ismagilov, professor, head of lecturer Electromechanics, Ufa State Aviation Technical University, Ufa, Russia. In 1973 he graduated from the Ufa Aviation Institute Electromechanics, Ph. D on the elements and control devices.



Irek Kh. Khayrullin, professor, department of electromechanics at the Ufa State Aviation Technical University Ufa, Russia, graduated from the Ivanovo Power Engineering Institute in 1963, Electromechanics faculty, Ph.D. in the elements and control systems.



Vyacheslav E. Vavilov, senior lecturer, department of Electromechanics, Ufa State Aviation Technical University Ufa, Russia. In 2010 he graduated from the Ufa State Aviation Technical University, majoring in electrical engineering. In 2013 he defended his thesis.



Ruslan D. Karimov, research assistant, department of Electromechanics, Ufa State Aviation Technical University Ufa, Russia. In 2010 he graduated from the Ufa State Aviation Technical University. Master of Engineering (USATU, 2012).



Anton S. Gorbunov, senior lecturer, department of Electromechanics, Ufa State Aviation Technical University Ufa, Russia. In 2011 he graduated from the Ufa State Aviation Technical University in the specialty «Electromechanics», Ph.D. in electrotechnical complexes and systems.



Danis R. Farrakhov, assistant lecturer, department of Electromechanics, Ufa State Aviation Technical University Ufa, Russia. In 2009he graduated from the Ufa State Aviation Technical University. Master of Engineering (USATU, 2011).