

# Monitoring and Fault-Recovery Capacity with Waveguide Grating-based Optical Switch over WDM/OCDMA-PON

<sup>A</sup> Yao-Tang Chang, <sup>B</sup> Chuen-Ching Wang, <sup>C</sup> Shu-Han Hu

**Abstract**—In order to implement flexibility as well as survivable capacities over passive optical network (PON), a new automatic random fault-recovery mechanism with array-waveguide-grating based (AWG-based) optical switch (OSW) is presented. Firstly, wavelength-division-multiplexing and optical code-division multiple-access (WDM/OCDMA) scheme are configured to meet the various geographical locations requirement between optical network unit (ONU) and optical line terminal (OLT). The AWG-base optical switch is designed and viewed as central star-mesh topology to prohibit/decrease the duplicated redundant elements such as fiber and transceiver as well. Hence, by simple monitoring and routing switch algorithm, random fault-recovery capacity is achieved over bi-directional (up/downstream) WDM/OCDMA scheme. When error of distribution fiber (DF) takes place or bit-error-rate (BER) is higher than  $10^{-9}$  requirement, the primary/slave AWG-based OSW are adjusted and controlled dynamically to restore the affected ONU groups via the other working DFs immediately.

**Keywords**—Random fault recovery mechanism, Array-waveguide-grating based optical switch (AWG-based OSW), wavelength-division-multiplexing and optical code-division multiple-access (WDM/OCDMA)

## I. INTRODUCTION

RECENTLY the numbers of Internet users have been increasing and the demand for broadband access has been growing quickly. In order to meet the needs of the multi-media high-speed access networks, passive optical network (PON) has applied and marched toward the fiber-to-the-home/curb/node (FTTx) services [1]. Because the network transmission capacity elevates continuously, people transmit large quantity of personal data constantly. Unfortunately, when the physical transmission medium (feeder fibers or distribution fibers, FFs and DFs) occur failure or the devices break off, the network will cause serious data loss and enormous disaster. Thus, how to design a high-quality recovery-protection mechanism is an important issue in the network management. In previous study, the protection schemes in TDM-PON [2] and WDM-PON [3-8] exist there. However, there is neither fault-recovery nor protection mechanism is investigated to emerge into optical code-division-multiplexing passive optical network

(OCDMA-PON) [9-10]. In TDM-PON scenario, the appendix in ITU-T G.983.1 [2] shows four protection schemes. However, they are not suitable to be applied in the current high-speed PONs because when the error occurs in some defective devices, the other normal working components are affected and result in data loss or other unpredicted side-effects. In the WDM-PON scenario, the group protection architecture (GPA) [3,4], each ONU in the network is paired with one another to form a group. The two ONUs in each group are interconnected via a fiber to provide a protection stream mutually. Similar to the GPA, the central protection scheme [5] not only uses two interconnection fibers (IFs) between ONUs in each same group and two feeder fibers (FFs), but also controls the protection mechanism. By using the optical switch (OSW) in the OLT side, The 1: N protection scheme [6-7] is composed of three FFs to transmit two different protection streams and protect all ONUs. In order to provide more consummate protection performance, a centralized alternative path protection scheme was proposed [8], and it uses double-devices (such as RNs, FFs, DFs and IFs...etc) to achieve the full-protection. However, many duplicated redundant elements are applied to result in the expensive equipment cost. In conventional OCDMA scheme [9], array-waveguide-grating (AWG) is usually used to encode and decode each user's up/downstream data by using its cyclic and free-spectral-range (FSR) properties. Also, the OCDMA scheme is configured to improve confidential capacity by designing various signature address codes [10]. However, there is neither protection nor fault-recovery mechanism over OCDMA-PON which is addressed by using the routing properties of AWG. In order to provide the confidential and fault-recovery mechanism over fiber-to-the-home (FTTH) networks which is characterized as central office (CO) of optical line terminal (OLT), it is connected to the geographic distribution location of the various optical network unit (ONU) groups. A new monitoring and fault-recovery with AWG-based automatic array-waveguide-grating based optical switch (AWG-based OSW) are implemented over WDM/OCDMA schemes [11]. Compared to conventional FTTH scheme, the proposed scheme is characterized with flexibility and scalability of WDM. Moreover, the proposed scheme achieves superior confidential capacity than previous works [2-10]. The most concerning in fault-recovery mechanism is those that decreasing the construction processing can not affect the other normal ones and prohibit the duplicated redundant elements. In current study, a new AWG-based OSW is configured as routers

<sup>A</sup> Yao-Tang Chang, Department of Electro-Optical Science and Engineering, Kao Yuan University, Taiwan (t10066@cc.kyu.edu.tw)

<sup>B</sup> Chuen-Ching Wang, Department of Information Management, Shu-Zen College of Medicine and Management, Taiwan (ccwang@ms.szmc.edu.tw).

<sup>C</sup> Shu-Han Hu, Department of Electrical Engineering, National Cheng Kung University, Taiwan (ytdgt@cc.kyu.edu.tw).

to implement a virtual star-mesh topology between each ONU group. Here, the called primary/slave AWG-based optical switches are properly applied to realize the fault-recovery solution. In current study, the error occurs on distribution fiber (DF) which is connected with the remote node (RN, such as combiner/splitter, star coupler, or AWG) and ONUs is investigated only. When the transmission failures occur or the bit-error-rate (BER) is over  $10^{-9}$  requirement, the primary/slave AWG-based OSW will be adjusted and controlled dynamically to restore the affected ONU groups via the other working DFs immediately. The remainder of this paper is organized as follows. Section II presents the brief concept of the fault-recovery capacity on WDM/OCDMA scheme. Section III presents the fault-recovery mechanism of WDM/OCDMA describes such as control unit, fault-detection unit about how to work, and explain the operations mode of the up/downstream while the fault occurs. In Section VI, we use the comparison table to compare the protection capability, equipment requirements and construction cost of the proposed mechanism with the others protection schemes in WDM-PON or TDM-PON. The conclusion is given in Section V.

II. MUTUALLY FAULT-RECOVERY CAPACITY ON WDM/OCDMA SCHEME

As shown in Fig.1, the conventional WDM/OCDMA system uses the periodic cyclic and free-spectral-range (FSR) properties of AWG routers to partition the total users (ONUs) into different ONU groups in accordance with the subscribers' geographical locations. Here, seven groups ( $G=7$ ), seven transmission wavebands ( $G_1 \sim G_7$ ), in each group ( $N=7$ ). A  $1 \times 7$  coarse AWG is configured in proposed scheme.

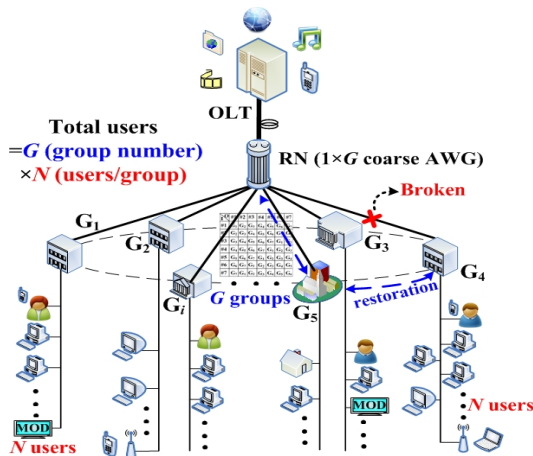

Fig.1 The geographic distribution location properties of integrated WDM/OCDMA-PON ( $G=7, N=7$ )

In order to achieve the bi-directional transmission and prevent the collision between the upstream and downstream traffic, central wavelength 1310/1550nm is used in the up/downstream respectively. In proper design, each ONU group's transmission waveband ( $G_i, i=1 \sim 7$ ) is divided into seven wavelengths ( $N=7$ ) which are encoded into various signature address codes for seven users in each group.

In current study, when  $i$ -th distribution fiber ( $DF_i$ ) which is between RN and ONU group  $\#i$  occurs error or breakdown suddenly, we should design an alternative solution to let the waveband  $G_i$  which contains the data of ONU group  $\#i$  be restored instantly by another normal- working group (ex: ONU group  $\#j$ ) via  $DF_j$ . In order to construct the WDM/OCDMA system with fault-recovery capacity, the traditional WDM/OCDMA scheme should be modified slightly and use central control unit, detection unit, and several OSWs. Importantly, a new automatic primary/ slave AWG-based OSW which is designed by the routing function of AWG is configured to control and manage the dynamic optical paths. In this way, a virtual star-mesh topology between each ONU group will be constructed and shown as Fig.2. The major difference between proposed and another partial protection scheme is that the proposed scheme uses the limited resources and reduces/decreases the duplicated redundant devices to achieve the random and mutual restoration capacity.

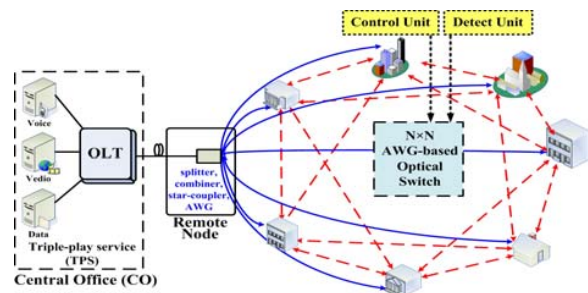

Fig. 2 Star-Mesh Topology of the proposed fault-recovery mechanism

The principle of the  $7 \times 7$  coarse AWG router is shown in Fig.3. The coarse AWG router de-multiplexes the whole downstream waveband into all of the output ports while the same group signals which are incident from different input ports will go to different output ports in the cyclic manner:  $(\#input\ port + \#output\ port - 1) \bmod G = \#Waveband$ . Note that  $G$  and  $G_i$  denote the size number of coarse AWG and the group number of transmission waveband respectively. For example, when waveband  $G_4$  is launched into the input port  $\#3$ , it will be routed to the output port  $\#2$  by previous formula, i.e.,  $(3 + output\ port\ number - 1) \bmod 7 = 4$ , the output port number will be port  $\#2$ .

I/O	#1	#2	#3	#4	#5	#6	#7
#1	$G_1$	$G_2$	$G_3$	$G_4$	$G_5$	$G_6$	$G_7$
#2	$G_2$	$G_3$	$G_4$	$G_5$	$G_6$	$G_7$	$G_1$
#3	$G_3$	$G_4$	$G_5$	$G_6$	$G_7$	$G_1$	$G_2$
#4	$G_4$	$G_5$	$G_6$	$G_7$	$G_1$	$G_2$	$G_3$
#5	$G_5$	$G_6$	$G_7$	$G_1$	$G_2$	$G_3$	$G_4$
#6	$G_6$	$G_7$	$G_1$	$G_2$	$G_3$	$G_4$	$G_5$
#7	$G_7$	$G_1$	$G_2$	$G_3$	$G_4$	$G_5$	$G_6$

Fig. 3 Input-Output connectivity in Coarse AWG

In proper design, a coarse AWG router presented in the Fig.4 is used to combine the wavelengths (in different groups) with the feeder fiber in the upstream transmission and separate the downstream transmission into the  $g$ -th group by filtering out the desired wavelength range  $\lambda_{g,1}$  to  $\lambda_{g,7}$  ( $\lambda_{g,n}$  corresponding to  $\lambda_{(g-1) \times 7 + n}$ , where  $g$  and  $n$  denote the group number and user

number in group # $g$ ) for each group. Note that the whole transmission waveband ( $\lambda_1 \sim \lambda_{49}$ ) is separated into seven groups (ONU group #1 to #7) by following the inherent FSR interval range of coarse AWG router. That is, all of the users in each group are assigned an individual maximum length sequence code (M-sequence code, where code length  $L=7$ ) as there's signature address code.

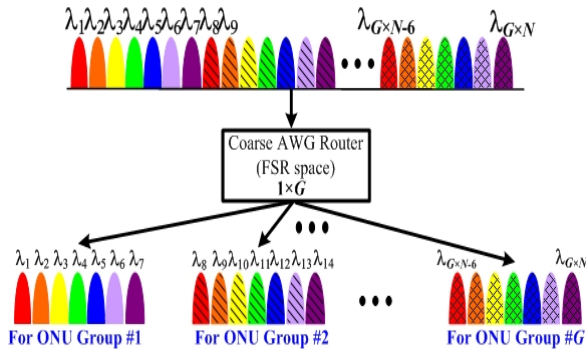

Fig. 4 Wavelength allocation of the WDM/OCDMA

III. PROPOSED FAULT-RECOVERY MECHANISM OVER WDM/OCDMA ARCHITECTURE

The proposed configuration and operation mechanism are shown in Fig.5. When distribution fibers (DF) which is between RN ( $1 \times 7$  Coarse AWG) and arbitrary ONU groups occur error and the blocking of the bit-error-rate (BER) is higher than threshold value (such as  $10^{-9}$ ), the proposed mechanism will use adjacent or random-selected ONU groups to substitute for the failure ONU groups to transmit the data packets. Here, in order to construct the WDM/OCDMA without fault-recovery mechanism, the original WDM/OCDMA scheme needs to be modified slightly (shown in the left side of Fig 5). Also, the detection unit and control unit that adjust the primary/ slave AWG-based OSW and programmable  $2 \times 1$  OSW are applied. In practical FTTH environment, the OLT is configured at central office. A slave AWG-based optical switch is designed at gate of campus. ONU groups are located at each building. And  $2 \times 1$  OSW and primary AWG-based OSW are located at central playground according to the various geographic distribution locations shown in Fig. 5.

Here, the operational processing for each component to achieve retire proposed mechanism is explained with the sequential expressions and diagrammatic sketch of the up/downstream transmissions shown as follows. Moreover, the detail path diagram will be shown in below section III.

- ①. Assume  $DF_3$  which is located between RN and ONU group #3 occurs error.
- ②. Detection unit transmits the testing signals to every DFs regularly, and each testing signal combined with the FF, then spitted into every DFs again and again.
- ③. Detection unit detects each DF, and distinguishes whether it received the testing signal or not (In Fig.5, detection unit found an error in  $DF_3$ ).

- ④. After detection unit finds an error in the  $DF_3$ , it sends the detection message (1101111) to the program which in the control unit (Bit 1 and 0 denote the fiber link is in normal working or breakdown situation).
- ⑤. After control unit receive the detection message, the program calculates the routing switch algorithm to choose the restored group, distinguishes the transmission which is in the upstream or downstream and adopts the various method. Firstly, the control unit transmits the control message to front end slave AWG-based OSW. Secondly, open the gates of this OSW to make faulty group ( $G_3$ ) and restored group ( $G_i, i=1 \sim 7$  except 3) and transfer their protection signal to each other successfully. Finally, the protected signal ( $G_3$ ) which is transmitted by adjacent group could be combined/spitted by  $1 \times 7$  coarse AWG.
- ⑥. Control unit adjusts the start-end port of the primary AWG-based OSW dynamically according to the results of routing-switch algorithm, and realizes the bi-direction dynamic loop-back and transfers the faulty group's waveband ( $G_i$ ) to the other right-side input ports of  $7 \times 7$  coarse AWG.
- ⑦. In order to switch four different fault-recovery mechanisms, the program in the control unit controls the  $2 \times 1$  OSW to switch two situations. (When in ONU group # $i$ : One situation is fiber breakdown on ONU group # $i$ , recovers its signal from another optical path. Another ones is fiber breakdown on ONU group # $j$ , uses group # $i$  to help # $j$  transfer optical path).

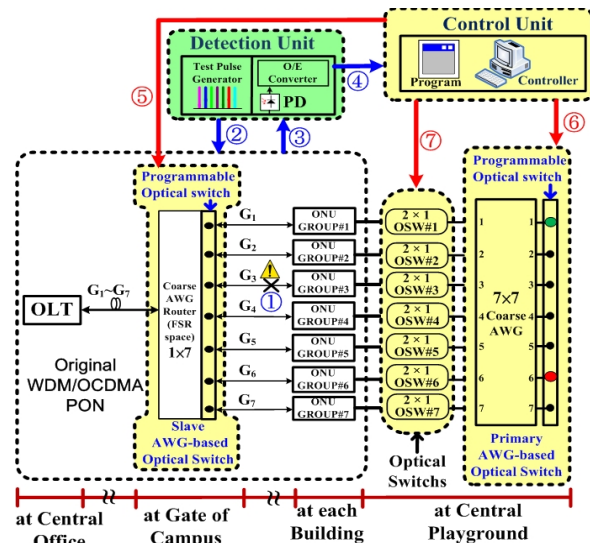

Fig. 5 Proposed Automatic Fault-Recovery mechanism

After the above steps, the broken ONU groups can be routed to the random chosen ONU groups automatically. The detail usage of each component in proposed mechanism will be elaborated as follows.

A. Detection Unit

In order to implement the detection scheme, the conventional wavelength assignment of WDM/OCDMA (in the previous Fig.4) should be modified slightly and re-splits the whole waveband into seven groups. Here, there are eight wavelengths in each group, as shown in Fig.6. The wavelengths



The front-end slave AWG-based OSW is used to change the input and output port of some numbers of transmission waveband. For instance, when  $DF_i$  occurs error, the waveband  $G_i$  can not serve the ONU group# $i$  neither in upstream nor downstream traffic. For the upstream traffic, if  $G_i$  is restored via  $DF_j$ , then  $G_i$  and  $G_j$  will enter to the port # $j$  of  $1 \times 7$  coarse AWG simultaneously.

### C. Path diagrams of the proposed mechanism in the up/downstream traffic

In this section, the above components are combined to implement the fault-recovery mechanism in up/downstream networks. The  $DF_3$  is assumed that error takes place and needs to be restored by  $DF_5$ . As shown in Fig.10, the path diagram between the ONU group #3 and ONU group#5 is only addressed. The rest of groups are in normal working mode. Following the below sequential expressions, the detail mechanism of proposed random fault-recovery mechanism is demonstrated as follows in the upstream transmission.

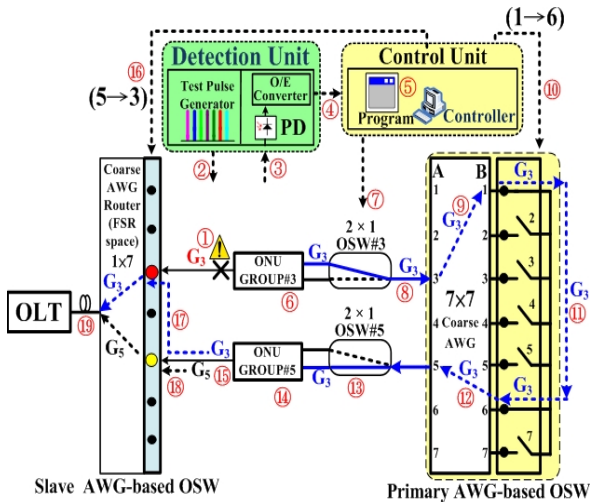

Fig. 10 Path diagram in the upstream network

①When  $DF_3$  occurs error → ②the test pulse generator sends the wavelengths  $\lambda_{g,8}$  to each  $DF_g$  → ③the detection device found an error in  $DF_3$  → ④sends the detection message (1101111) to the program → ⑤ the program computes the decisions and loop-back methods via the routing functions of AWG → ⑥ switch ONU group#3 to the “restore mode” → ⑦switch the  $2 \times 1$  OSW #3 to the “restore mode” → ⑧the waveband  $G_3$  enters to the port#A3 of the primary AWG-based OSW → ⑨follow to the Fig.3,  $G_3$  will be routed into the port #B1 → ⑩⑪Control unit turns on the port#1 and #6 of the dynamic optical path switches, to ensure  $G_3$  will transfer from #B1 to #B6 → ⑫when  $G_3$  enter to the port#B6, it will be routed to port#A5 → ⑬switch the  $2 \times 1$  OSW #5 to the “help mode” → ⑭ONU group#5 also

switch to the “help mode” → ⑮ in this way, the restored waveband  $G_3$  and original  $G_5$  are transmitted via  $DF_5$  → ⑯ Because of the coarse AWG is only combining/splitting the waveband in the form of group, the control unit switch the port#3 and #5 of the slave AWG-based OSW dynamically → ⑰ to ensure  $G_3$  can be separated from  $DF_5$ , then transfer to the port#3 → ⑱  $G_5$  will enter to the port#5 as usual → ⑲ the transmission wavebands which in their own port of the  $1 \times 7$  coarse AWG will be combined with feeder fiber.

Moreover, the fault-recovery mechanism in the downstream traffic is presented as the path diagram shown in Fig.11.

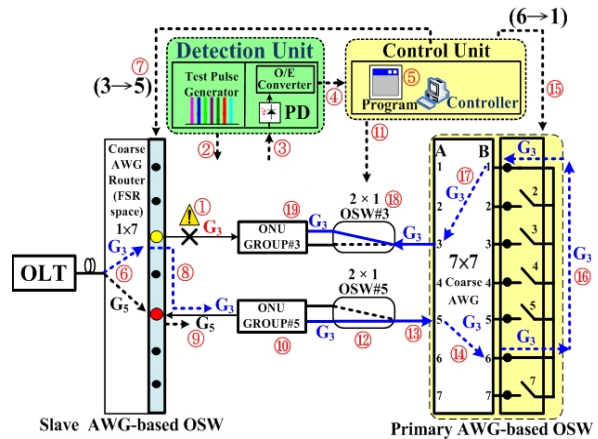

Fig.11 Path diagram in the downstream network

Following the ①②③④⑤⑦ steps, when  $DF_3$  occurs error, detection unit sends the detection message to the program, and control unit turns on the port#3 and port#5 of the dynamic optical path switch → ⑥⑧⑨Let  $G_3$  be transferred to  $DF_5$ , and combined with  $G_5$  to arrive the ONU side → ⑩⑪⑫Switch the ONU group#5 and  $2 \times 1$  OSW #5 to the “help mode”, the downstream waveband  $G_5$  will enter to its own group, but  $G_3$  will be filtered out by the ONU group #5 → ⑬⑭⑮⑯After  $G_3$  entering the port#A5 of the  $7 \times 7$  coarse AWG, it will be routed to the port#B6. The control unit turns on the port#6 and #1 of the dynamic optical path switches simultaneously, to ensure  $G_3$  will transfer from #B6 to #B1 → ⑰ After  $G_3$  enter to the port#B1, it will be routed to port#A3 → ⑱switch the  $2 \times 1$  OSW #3 and ONU group#3 to the “restored mode”, to receive the downstream data via  $DF_5$ .

### IV. SYSTEM PERFORMANCE COMPARISONS

In this section, the proposed fault-recovery mechanism and another protection schemes which in the literature [2-8] is compared in terms of its protection capability, duplicated redundant elements, required wavelengths, building complexity/flexibility and routing switch algorithm. The results is shown and summarized in Table 1.

In protection capability scenario, the appendix in ITU-T G.983.1 [2] shows four protection schemes. In these schemes, feeder fiber or distribution fiber can be protected in different conditions. In schemes [3-7], they only protect the distribution fiber, but the alternative path protection scheme [8] can protect the feeder fiber by using duplicated fibers. However, when distribution fiber between RN and each group occurs error (broken), the proposed mechanism creates the virtual star-ring topology to protect users' data traffic. Hence, the distribution fiber protection is provided by the logical linkage (i.e., different from physical linkage). Furthermore, the proposed scheme can be modified to achieve feeder fiber protection that is achieved interconnection/inter-protection by our proposed AWG-based OSW while the subscribers are located in different area.

TABLE I  
COMPARISON OF FAULT-RECOVERY/PROTECTION SCHEME OVER TDM/WDM/OCDMA-PON

Fault-Recover/ Protection Scheme	Protection capability		Duplicated redundant elements (fiber or transceivers)	No. of required wavelengths	Building complexity and flexibility	Routing switch algorithm
	FF	DF				
ITU-T G.983.1 [2] in TDM-PON	FF or DF		FFs/ DFs/ OLT/ RN or ONU devices	Constant	Add FFs/ DFs/ OLT/ RN or ONU devices	Not mentioned
Group protection (GPA) [3,4]	No	Yes	One interconnection fiber (IF) in each ONU	Increase	Add IFs and link to another ONU partner	Fix selection routing
Central protection scheme [5]	No	Yes	Two FFs is used, two IFs between each ONU in one group	Increase	Add double IFs and link to another ONU partner	Fix selection routing
1:N protection scheme [6,7]	No	Yes	(N/2+2) FFs are used	Constant	(N/2+2) FFs are used, and add N times IFs for each ONU.	Fix selection routing
Centralized alternative path protection scheme [8]	Yes	Yes	Double FFs, DFs, and RN. Furthermore, one AWG used in OLT	Increase	Without OLT and ONU, all devices need to be doubled	Fix selection routing
Proposed Fault-Recovery mechanism over WDM/OCDMA	Not yet	Yes	Primary AWG-based OSW used to change various optical paths. (Because of there is no the others duplicated redundant elements, so only protects DFs)	Constant	Modify original RN, and only add a short fiber between each ONU group and primary AWG-based OSW when adding new ONU group)	Random-selection routing (blind optimum routing algorithm)

As shown in Table I, the duplicated redundant elements and complexity in construction are investigated in various schemes. Firstly, GPA scheme [3, 4] and the central protection scheme [5] are needed to increase one and two interconnection fiber between each user in the same group, respectively. Secondly, since 1:N protection schemes were employed, they use (N/2+2) feeder fibers to accomplish its capability [6, 7]. Many duplicated redundant devices are applied and then cause expensive construction cost [8]. For improving the conventional scheme, the proposed scheme only modifies the previous RN into slave AWG-based OSW, and also adds one primary AWG-based OSW behind all ONU groups and links it to each ONU group. By this way, one short fiber is only added to connect with primary AWG-based OSW and then ONU group can achieve a new restoration capacity in OCDMA scheme. In order to realize the various protection schemes, some schemes [3-5, 8] need to increase additional wavelength to avoid the wavelength collision and conform the routing function of RN. The proposed mechanism and scheme [2,8] apply constant numbers of wavelength to accomplish protection/restoration capability. Furthermore, the proposed

mechanism only uses the routing property of AWG to transfer specified group waveband to another group. Compared to conventional [2-8] which uses proposed primary AWG-based OSW, a new random-select arbitrary group is achieved to provide faulty ONU group (without using duplicated and fixed components) to restore the traffic by selecting limited partner/group.

## V. CONCLUSION

In order to implement the various flexibility and survivable capacities over passive optical network (PON) and also prohibit the duplicated redundant elements such as fiber/transceiver, a new random fault-recovery mechanism for bidirectional up/downstream with array waveguide grating-based (AWG-based) optical switch (OSW) is demonstrated to implement central star-mesh topology likely over WDM/OCDMA scheme. By incorporating dynamic optical path switching into remote node (RN, 1×G coarse AWG) and using several 2×1 optical switches, one back-end primary AWG-based OSW is without duplicated redundant devices and the faulty ONU groups' data is transferred by the others normal-working groups arbitrarily.

Furthermore, the advanced fault-recovery mechanism is investigated to protect and backup in feeder and distribution fiber components.

## REFERENCES

- [1] K.S. Kim, "On the evolution of PON-based FTTH solutions," Information Sciences, vol. 149/1-2, pp. 21-30, Jan. 2003.
- [2] ITU-T, Recommendation "Broadband optical access systems based on passive optical networks (PON)," ITU-T, Recommendation G. 983.1, 1998.
- [3] T.J. Chan, C.K. Chan, L.K. Chen, F. Tong, "A self-protected architecture for wavelength division multiplexed passive optical networks," IEEE Photon. Technol. Lett. 15 (11), pp. 1660-1662, 2003.
- [4] C.M. Lee, T.J. Chan, C.K. Chan, L.K. Chen, C. Lin, "A group protection architecture for traffic restoration in multi-wavelength passive optical networks," European Conference on Optical Communication (ECOC), 2003, Th2.4.2.
- [5] Z.X. Wang, X.F. Sun, C.L. Lin, C.K. Chan, L.K. Chen, "A novel centrally controlled protection scheme for traffic restoration in WDM passive optical networks," IEEE Photon. Technol. Lett. 17 (3) pp. 717-719, 2005.
- [6] C.C. Sue, "A novel 1:N protection scheme for WDM passive optical networks," IEEE Photon. Technol. Lett. 18 (13) (2006) 1472-1474.
- [7] C.C. Sue, "1:N protection scheme for AWG-based WDM PONs," IEEE Globecom, San Francisco, Dec. 2006, OPN01-1.
- [8] X. Sun, C.K. Chan, L.K. Chen, "A survivable WDM-PON architecture with centralized alternate-path protection switching for traffic restoration," IEEE Photon. Technol. Lett. 18 (4) (2006) 631-633.
- [9] N. Karafolas and D. Uttamchandani, "Optical Fiber code Division Multiple Access Networks: A Review," Optical Fiber Technology, vol. 2, pp. 149-168, April 1996.
- [10] C. Yang, Jen-Fa Huang, and S. Tseng, "Optical CDMA network codecs structured with M-sequence codes over waveguide-grating router," IEEE Photon. Technol. Lett., vol. 16, pp. 641-643, Feb. 2005.
- [11] J.F. Huang, Y.T. Chang and C.C. Hsu, "Hybrid WDM and optical CDMA implemented over waveguide-grating-based fiber-to-the-home networks," Opt. Fiber Technol. 13 (3), pp. 215-225, 2007.