

Modeling and Simulation of a Hybrid Scooter

W. K. Yap, and V. Karri

Abstract—This paper presents a hybrid electric scooter model developed and simulated using Matlab/Simulink. This hybrid scooter modeled has a parallel hybrid structure. The main propulsion units consist of a two stroke internal combustion engine and a hub motor attached to the front wheel of the scooter. The methodology used to optimize the energy and fuel consumption of the hybrid electric scooter is the multi-mode approach. Various case studies were presented to check the model and were compared to the literatures. Results shown that the model developed was feasible and valuable.

Keywords—Hybrid electric scooters, modeling and simulation, hybrid scooter energy management.

I. INTRODUCTION

HYBRID electric scooters (HES) have a great potential in lowering emissions and reducing fuel demand as the ever growing problems of air pollution and global warming reached its critical stage. Although various researches are carried out to reduce emissions and fuel dependencies for four-wheeled vehicles, not much research are focused on two-wheeled vehicles.

Two-wheeled vehicles, especially motorcycles and scooters contribute to a major part of air pollution, especially in the Asia region [1]. For example, motorcycles in Jakarta, Indonesia contributed to more than 20% in both PM_{10} and CO and 40% of HC emissions during 1998 [2]. Whereas in Hanoi, Vietnam, motorcycles contributes to about 54% of CO, HC and Pb and 43% of dust [3]. Finally, in Taiwan where emissions reports indicate that 38% of CO, 3% of NO_x , 64% of NMHC and 30% of PM were emitted from motorcycles and scooters alone [4].

Currently, there are over 400,000 motorcycles and scooters registered in Australia [5] and using a reasonable comparison, the amount of harmful emissions produced by these two-wheeled vehicles are not much off from their Asian counterparts

Various steps are taken by federal governments to curb air pollution. For example, the government of Taiwan has implemented some policies such as the strict exhaust standards for gasoline vehicles as well as a subsidy for purchasing electric scooters [6]. However, the goals of replacing traditional petrol scooters were not successful [7].

Thus a hybrid approach, which is to utilize an internal combustion engine (ICE) and a battery, is more feasible as a

much higher range could be achieved compare to pure electric scooters. The only trade-off is that emissions are not reduced to zero. Thus two-wheeled hybrid research is as equally as important as four-wheeled vehicles and should not be neglected.

Since fuel economy and emissions as well as battery usage are primary factors to be considered in the operation of hybrid vehicles, various modeling and simulation softwares and methods are introduced to optimize these factors. The two main issues involved in energy management of hybrid scooters (or hybrid vehicles in general) mainly involved the power distribution of the propulsion units and charge sustenance of the battery. By modeling and simulating a *prototype*, various factors (including power splits and charge sustenance) can be addressed and predicted via simulation before constructing the hybrid electric scooter.

This showed modeling and simulation based analysis and research are crucial to the development of hybrid vehicle design since design validation by hardware measurement is impractical prior to the costly prototype building [8]. Several computer programs had been developed to describe the operations of hybrid powertrains, including simple EV simulation (SIMPLEV) from the DOE Idaho National Laboratory, MARVEL from Argonne National Laboratory, CarSim from AeroVironment Inc., JANUS from Durham University, ADVISOR from DOE's National Renewable Energy Laboratory and Vehicle Mission Simulator Model (ELPH) from Texas A & M University [9]. All the software mentioned above are all developed and catered for four-wheeled vehicles. There are no reports for two-wheeled hybrid electric vehicles [10].

This paper presents a HES model developed and simulated using Matlab/Simulink platform. The energy management strategy used to optimize the energy and fuel consumption of the HES is the multi-mode method. This multi-mode method was also discussed by Zhang et. al. [8] to be applied on the Toyota Prius and substantial improvements are showed in terms of energy and fuel consumptions. This method is discussed on this paper and applied to the HES modeled. The performance was then simulated under various driving cycles. Data analysis was carried to compare with the literatures to check for feasibility.

II. MODEL DEVELOPMENT

The dynamic models presented in this section show each individual model that makes up the HES. Each individual model was developed in Matlab/Simulink. The models are vehicle dynamics model, hub motor model, battery model and the internal combustion engine (ICE) model that makes up the

W. K. Yap is with the School of Engineering, University of Tasmania, Hobart Tasmania 7001, Australia (phone: +603-6226 2142; fax: +603-6226 7247; e-mail: wkyap@utas.edu.au).

V. Karri is with the School of Engineering, University of Tasmania, Hobart Tasmania 7001, Australia (e-mail: Vishy.Karri@utas.edu.au).

entire HES structure. The features of this HES model are as follows:

- 1) The model developed can be simulated on any driving cycle but the boundary conditions must be met. The boundary conditions include maximum speed of the scooter and the hub motor as well as the maximum power of the ICE and the hub motor.
- 2) The entire model developed is a function of the speed of the scooter, road inclination, the rider's weight and the acceleration. Variables such as torque requirements, power requirements as the state of charge of the battery can be determined.
- 3) Fuel consumption and energy consumption can be predicted from the model. Initial conditions have to be inputted to the model before simulation.

The model developed imitates the actual riding conditions of a Bug 90cc Escape Gasoline Scooter. This scooter type was chosen as it is readily available on the market. This gasoline scooter was converted to a hybrid scooter in the model, to check the behavior as well as the power and torque performances. Fig. 13 shows the Matlab/Simulink model developed.

III. OPERATION MODES

Six modes governed the operation of the HES over the entire driving cycle. Each mode was identified by assigning some certain boundary conditions. These boundary conditions served as a signal when this mode operates during the driving conditions. The modes are shown below.

Charging mode. This mode is where the ICE is operating the scooter, while recharging the set of batteries through the DC generator. This is the most efficient mode for highway-cruising, as well as speeds just under 40 kph (urban areas). The batteries upper and lower thresholds are defined, which makes selection of this mode easier.

Hybrid mode. The hybrid mode is used when high power is required. These conditions include acceleration and uphill travelling. In this mode, ICE and the hub motor are coupled to increase the scooter's power, thus increasing the torque delivered. If the torque requested for propulsion exceeds the maximum torque available, the missing power is then supplied by whichever source comes first.

Motor mode. This mode operates during start-up and low speed conditions of the scooter. The maximum speed achievable by the hub motor is about 25 kph. Therefore this mode is only suitable for speeds demanded that less than or equals to 25 kph. The batteries' state of charge (SoC) percentage plays a big part when choosing this mode. A low SoC (40%) would not operate this mode, as battery recharging is required.

Stand-still recharging mode. This mode operates when the HES is at idle conditions. This mode basically recharges the batteries via the generator when the SoC is low (40%).

ICE mode. This mode is to be used as minimal as possible, which in turn reduces the emissions and the fuel consumption of the hybrid electric scooter. This mode is used when the

torque and speed demanded exceeds the maximum torque and speed of the hub motor and the hybrid mode.

Regenerative braking mode. This operation mode can only occur when the batteries are not over the upper threshold limit; in this case is 80% of the full charge.

Note that when switching between each mode, a hysteresis gap is introduced (which is normally $\pm 5\%$ of the value) to avoid engine cycling from on and off mode. Six modes describe above makes up the HES' operating behavior for any given driving cycle.

Each mode was given a specific number during simulation so that the entire switching can be analyzed. This will be discussed in the Section IV: Simulation and Results.

IV. SIMULATION AND RESULTS

This model was simulated in various operating conditions and driving cycles. A driving cycle is a standardized pattern, which is described by a speed-time plot. Each acceleration is assumed to be constant. The four driving cycles used to simulate and test the model are:

ECE-15. ECE-15 driving cycle is a European driving cycle standard. This driving cycle represents urban driving in European countries. It is characterized by low vehicle speed, low engine load, and low exhaust gas temperature. The speed-time plot is shown in Fig. 1.

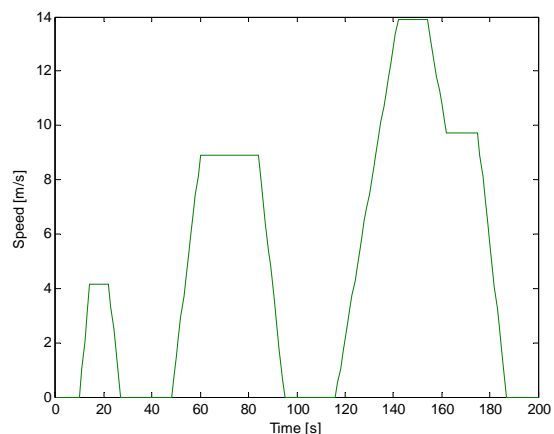

Fig. 1 ECE-15 Driving Cycle

UDDS. The Urban Dynamometer Driving Schedule (UDDS) is an American driving cycle standard. It is used to simulate city driving in the United States. This driving cycle is normally used for light-duty vehicles. The driving cycle is shown in Fig. 2.

NYCC. The New York City Cycle (NYCC) driving cycle was chosen due to its stop and go characteristics. It is used to simulate driving in New York City, United States. This features low speed traffic conditions. The plot is shown in Fig. 3.

HWFET. Highway Fuel Economy Driving Schedule (HWFET) represents highway driving conditions under 96 kph. This is also another American standard, released by the Environmental Protection Agency (EPA). Fig. 4 shows the driving cycle plot.

These driving cycles are chosen based on each driving cycle have their own distinct features and driving conditions. Two city driving, one urban driving and one highway driving to test the feasibility of the model developed. The UDDS and HWFET cycles are modified to a lower and constant maximum speed as the original cycle exceeds the maximum speed of the HES, which is just 80 kph.

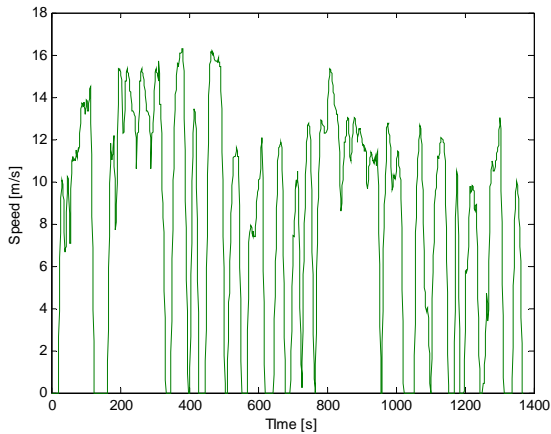

Fig. 2 Modified UDDS Driving Cycle

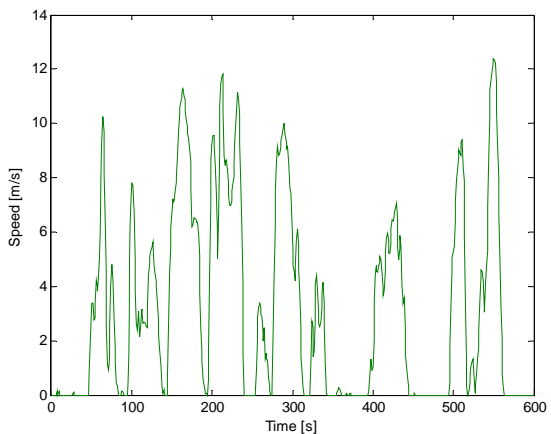

Fig. 3 NYCC Driving Cycle

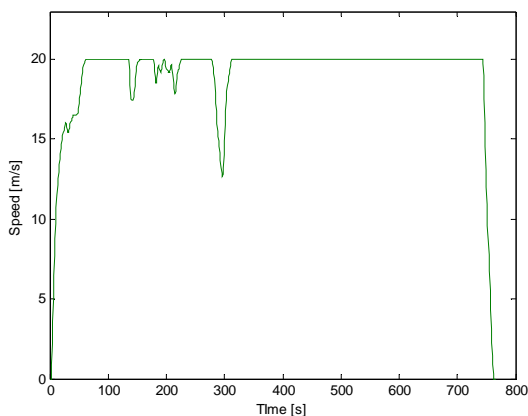

Fig. 4 Modified HWFET Driving Cycle

The model was modeled around a Bug Escape 90cc Scooter. The reason this scooter was chosen because it is easily obtainable in the market. The hub motor chosen was an Island Earth GL2 hub motor. Table I shows the manufacturer's data for the scooter. The model was built around these two components.

Each mode was given a number so that it could be identified later; ICE Mode (1), motor alone mode (2), hybrid mode (3), standstill recharging mode (4), mechanical braking mode (5), regenerative braking mode (6) and charging mode (7).

A. ECE-15 Driving Cycle

This is an urban European driving cycle and it is simulated with the developed model. The power splits between the two propulsion units i.e. ICE and the motor is shown in Fig. 5 and the modes for the entire driving cycle is shown in Fig. 6.

TABLE I
SCOOTER'S MANUFACTURER'S DATA

Parts	Characteristics
Engine	2 Stroke air cooled
Displacement	90 cc
Transmission	Auto CVT
Starting System	Electric Kick
Fuel Capacity	5.5 Litres
Wheels/Tyres Front	120/70-12
Rear	120/70-13
Brakes F/R	Disc/Drum
Suspension Front	Hydraulic Damper
Rear	Adjustable Coil Spring
Weight	85 kg
Wheel Construction	Alloy
Head	Halogen

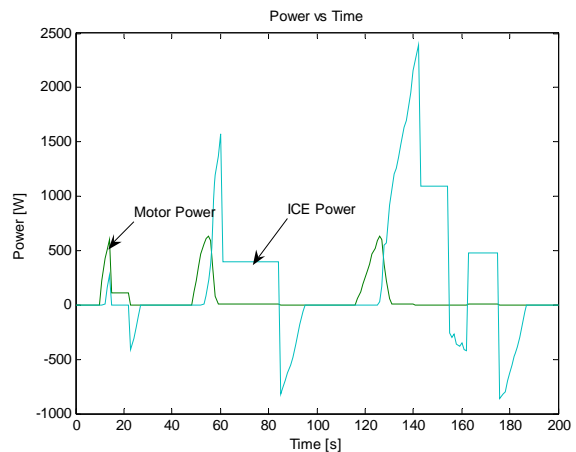

Fig. 5 Power Split Plot for ECE-15 Cycle

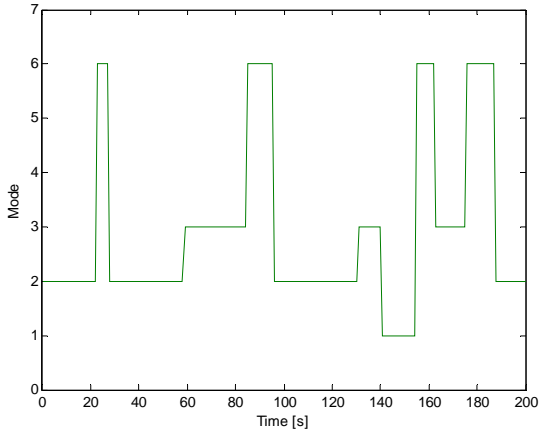

Fig. 6 Modes for ECE-15 Cycle

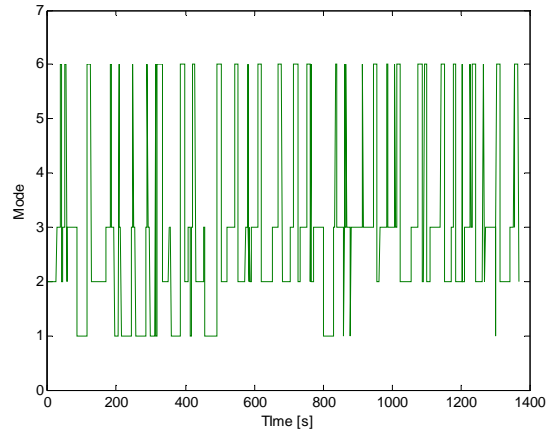

Fig. 8 Modes for UDDS Cycle

From Fig. 5, the power splits between the ICE and the motor is directly proportional to the modes (Fig. 6). Fig. 6 shows that the ICE is working in minimal as there is only one time the ICE is working (mode 1). Most of the time during the entire driving cycle, hybrid mode and motor-alone mode are working, with of course the regenerative mode during braking which recharges the batteries.

Comparing to the literatures by Shao [10], the power trends shown in Fig. 5 matched the trends published by Shao. The power values are not identical as different scooters are modeled but the trends are similar. This concludes that our model is feasible and valuable.

Having a feasible model, various variables can be predicted like emissions, costs, as well as fuel consumption before construction begins.

B. UDDS Cycle

Having a feasible model, testing on the UDDS cycle would give a better understanding of the behavior of the model and the HES. Figs. 7 and 8 shows the power splits and modes for this driving cycle.

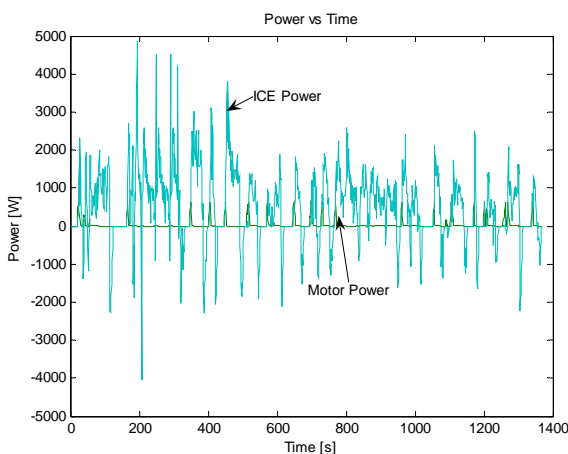

Fig. 7 Power Split Plot for UDDS Cycle

From the modes plot, the ICE (mode 1) is rarely used as well in this driving cycle. Motor-alone mode and hybrid mode are often used throughout this driving cycle, which is what we are expecting. By minimizing the ICE usage, fuel can be saved which in turns reduces emissions.

C. NYCC Cycle

Now simulating the model on the NYCC cycle, the power splits and modes are shown in Figs. 9 and 10. What's interesting with this cycle is that the ICE was never operated alone. The motor-alone mode and hybrid mode operates mostly for this cycle. This shows again that emissions were lowered as the fuel consumption is minimal. Regenerative braking mode is operating throughout the entire cycle as this is a stop-and-go cycle, one of the characteristics to be tested in the NYCC cycle.

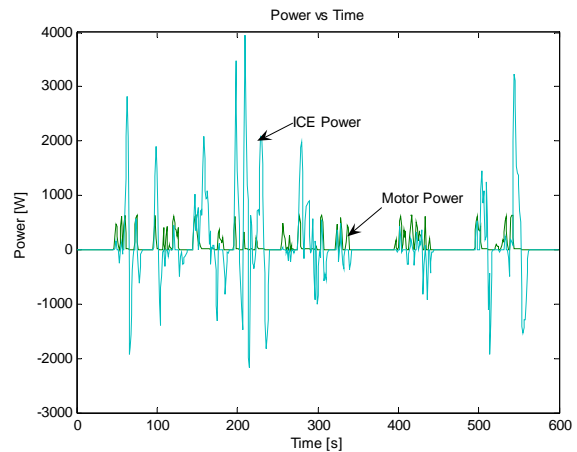

Fig. 9 Power Split Plot for NYCC Cycle

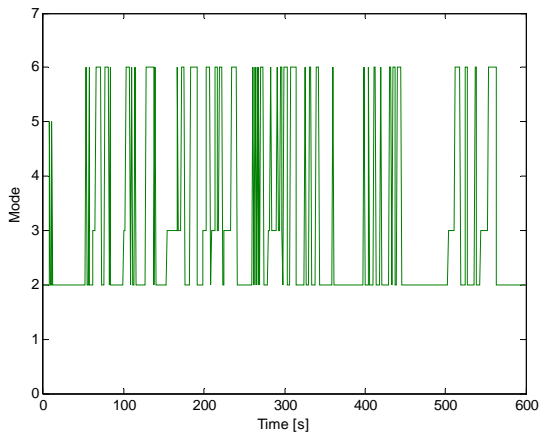

Fig. 10 Modes for NYCC Cycle

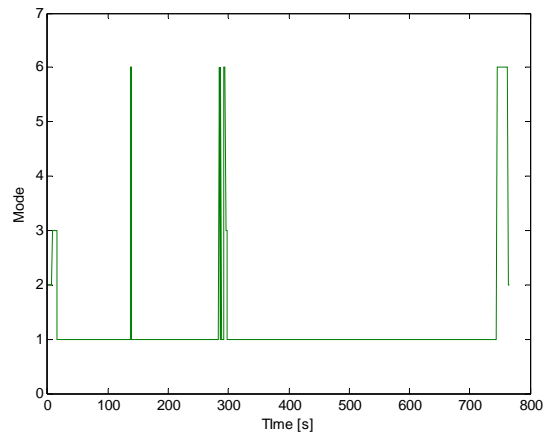

Fig. 12 Modes for HWY Plot

D. HWY Cycle

This highway cycle was chosen to see how the model and the HES reacts when travelling in a highway. It was predicted that the engine operates most of the time, while recharging the set of batteries. Figs. 11 and 12 show the behavior of the HES for this cycle.

From the power split plot, the motor was not used during the cycle but just for the start-up (at the beginning of the cycle). After that during highway cruising, the ICE operates alone for most of the time, which is what was predicted in the beginning.

The state of charge of the battery was monitored constantly and if its below the threshold value set, the ICE will run the generator to recharge the batteries, while still cruising in the highway.

V. CONCLUSION

This paper discusses a simulation of a hybrid electric scooter using the Matlab/Simulink platform. Four modes were simulated. The ECE-15 cycle was simulated and verified with the literature. This concludes that our model developed was feasible. With that, three other modes were then simulated to test the behavior of the scooter. All results obtained were all within the initial prediction.

Having a feasible and working model allows us to predict future important variables, such as emissions, fuel consumptions and energy efficiencies. This multi mode approach applied to the model provides flexibility for vehicle optimization in the future. The simulation results verify the capabilities of this control strategy.

Future addition and simulation will have a high confidence level as the model developed was working and feasible, as compared to the literature [10].

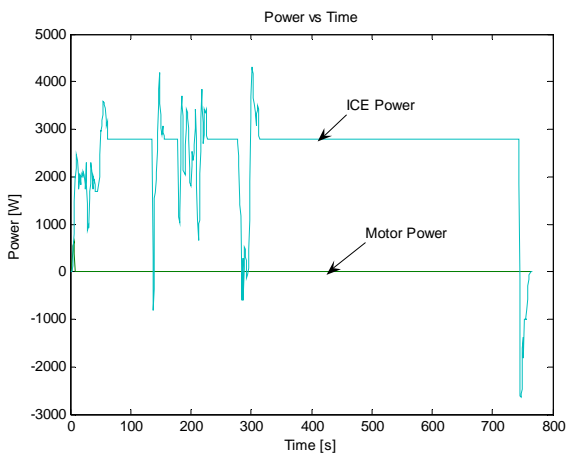

Fig. 11 Power Split Plot of HWY Cycle

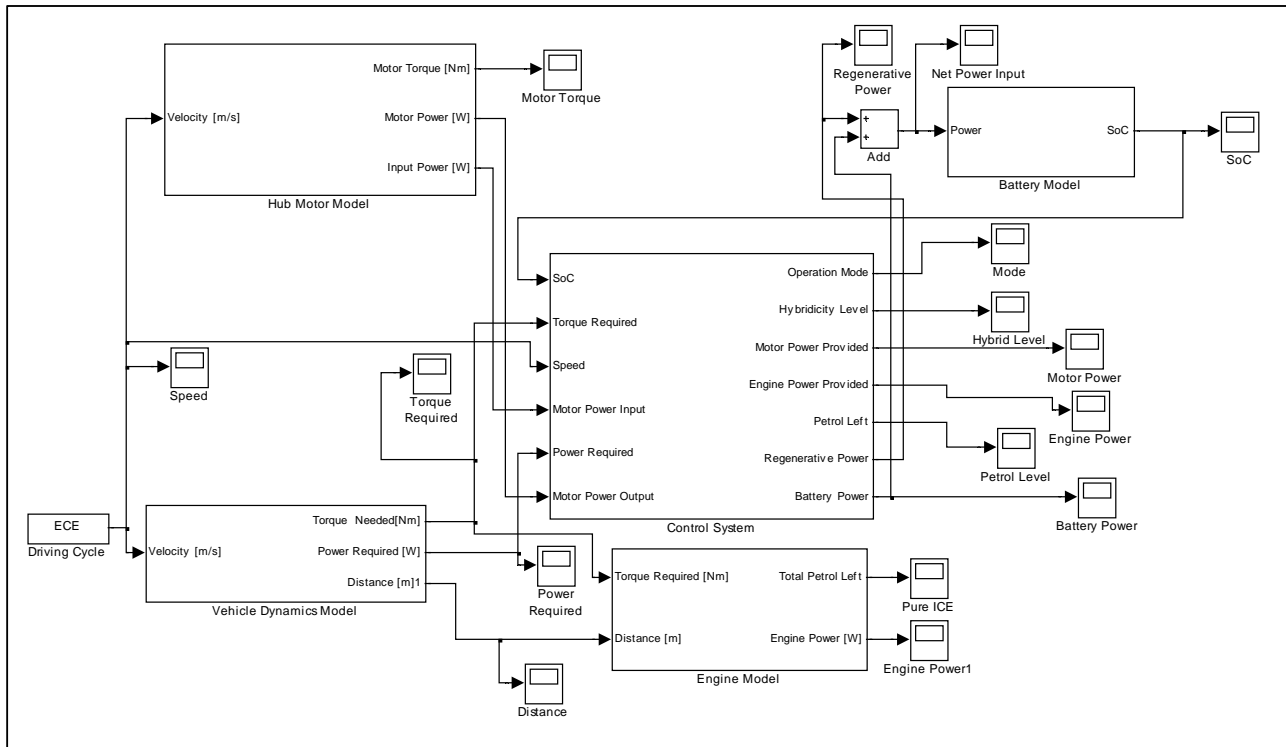

Fig. 13 Developed Matlab/Simulink HES Model

REFERENCES

- [1] Xiannuan, J. L., and Karen R. P., 1998, "Energy Use and Air Pollution Impacts of China's Transportation Growth in Energizing China", Reconciling Environmental Protection and Economic Growth, Harvard University Press: Cambridge, MA.
- [2] Asian Development Bank, 2002a, "Integrated Vehicle Emission Reduction Strategy for Greater Jakarta, Indonesia".
- [3] Asian Development Bank, 2002b, "Integrated Action Plan to Reduce Vehicle Emissions in Vietnam".
- [4] TEPA, 1997a., "State of the Environment", Environmental Protection Administration, Taipei, Taiwan.
- [5] Australia 2007 Statistic Report, 2007, <http://www.abs.gov.au/AUSSTATS/abs@.nsf/7d12b0f6763c78caca257061001cc588/d203aadecab752ccca25728f000d0466!OpenDocument>
- [6] Y. C. Chiu and G. H. Tzeng, 1999, "The mMarket Acceptance of Electric Motorcycles in Taiwan Experience through a Stated Preference Analysis", *Transport Res Part D4*, pp. 127-146.
- [7] C. Tso and S. Y. Chang, 2003, "A Viable Niche Market: Fuel Cell Scooters in Taiwan", *International Journal of Hydrogen Energy*, 28, pp. 757-762.
- [8] Zhang, Y., Lin, H., Zhang, B., and Mi, C., 2006, "Performance Modeling and Optimization of a Novel Multi-mode Hybrid Powetrain", *ASME Journal of Mechanical Design*, 128, pp. 79-89.
- [9] K. L. Butler, M. Ehsani and P. Kamath, 1999, "A Matlab-based Modeling and Simulation Package for Electric and Hybrid Electric Vehicle Design", *IEEE Transactions on Vehicular Technology*, 48(6), pp. 1770-1778.
- [10] D. G. Shao, Y. B. Li, X. Y. Wang and J. Z. Jiang, 2003, "A Matlab-based Simulation for Hybrid Electric Motorcycle", *Journal of Shanghai University (English Edition)*, 7(2), pp. 178-184.