

# Mitigation of Sag in Real Time

Vijay Gajanan Neve, Pallavi V. Pullawar, G. M. Dhole

**Abstract**—Modern industrial processes are based on a large amount of electronic devices such as programmable logic controllers and adjustable speed drives. Unfortunately, electronic devices are sensitive to disturbances, and thus, industrial loads become less tolerant to power quality problems such as sags, swells, and harmonics. Voltage sags are an important power quality problem. In this paper proposed a new configuration of Static Var Compensator (SVC) considering three different conditions named as topologies and Booster transformer with fuzzy logic based controller, capable of compensating for power quality problems associated with voltage sags and maintaining a prescribed level of voltage profile. Fuzzy logic controller is designed to achieve the firing angles for SVC such that it maintains voltage profile. The online monitoring system for voltage sag mitigation in the laboratory using the hardware is used. The results are presented from the performance of each topology and Booster transformer considered in this paper.

**Keywords**—Booster Transformer, Fuzzy logic, Static Var Compensator, Voltage sag.

## I. INTRODUCTION

**B**OTH electric utilities and end users of electrical power are becoming increasingly concerned about the quality of electric power. The term *power* quality has become one of the most prolific buzzword in the power industry since the late 1980s [9]. Power Quality is simply the interaction of electrical power with electrical equipment. If electrical equipment operates correctly and reliably without being damaged or stressed, then the electrical power is of good quality. On the other hand if the electrical equipment malfunctions, is unreliable, or is damaged during normal usage, then the power quality is poor.

Due to increasing complexity in the power system, voltage sags becoming one of the most significant power quality problems. Voltage sag is a short reduction voltage from nominal voltage occurs in a short time, voltage swell is an increase in the rms voltage from its nominal voltage; they are bound to have a greater impact on the industrial customers. If the voltage sags exceed two or three cycles, then manufacturing systems making use of sensitive electronic equipments are likely to be affected leading to major problems. It ultimately leads to financial losses [7].

Literature review is useful to understand in the depth knowledge of problem formulation. The following papers

Vijay Gajanan Neve is with the PhD student of Shree Sant Gajanan Maharaj College of Engineering, Shegaon, Maharashtra, India (phone: 91 9370159304; e-mail: vijay\_neve@rediffmail.com).

Pallavi V. Pullawar is with the ME student of Shree Sant Gajanan Maharaj College of Engineering, Shegaon, Maharashtra, India (phone: 91 9370159304; e-mail: pallavipullawar55@gmail.com).

G. M. Dhole is the Professor of Electrical Engineering Department, Shree Sant Gajanan Maharaj College of Engineering, Shegaon, Maharashtra, India (phone: 91 9823741641; e-mail: gmdhole@gmail.com).

were obtained from a variety of publications such as IEEE transactions on power delivery.

In [1], a laboratory model of an advanced var compensator (ASVC) was constructed to examine its capability for voltage sag mitigation and the main structure of the laboratory ASVC is presented. Its mitigation effect on voltage sags of different magnitude is then demonstrated. Tests carried out on a laboratory ASVC have shown that it can improve the load voltage sag by 4% to 21% depending on its initial operating point. The response time is about two and a half cycles of the power system frequency. The post-sag overshoot is up to 15% with a deep sag. Also tests have shown that an ASVC installed at a system with high source impedance can achieve a better mitigation effect on voltage sags.

In [2], a small scale static var Compensator (SVC) circuit that could be used as either a laboratory demonstration or a laboratory experiment. The small scale SVC lab experiment effectively demonstrates SVC's function in correcting power factor through the use of power thyristors in a phase-controlled circuit. The Static VAR Compensator showed that it is capable of improving the power factor of an inductive load. As only a non-varying inductive load was tested, the SVC is still able to accommodate for a varying load with the phase control in the thyristors. Being able to vary the capacitance or inductance of a circuit is very beneficial because it makes the correction more flexible and cost efficient. Yet, adding an overly large capacitor could result in an over-compensation which would require less delay angle for the system to be close to unity power factor.

In [3], the automatic control circuit has been implemented using microcontroller and tested with the Single Machine Two Bus Test system (SMTB) without and with SVC. Experimental results are presented and P-V Curves have been drawn for both the cases. Automatic control circuit have been designed and fabricated using LPC 2148 Microcontroller. The P-V Curves of the SMTB Test system with and without SVC have been plotted which shows the effectiveness of SVC on Voltage Stability improvement.

In [4], Voltage sags are an important power quality problem for which the dynamic voltage restorer (DVR) is known as an effective device to mitigate them. The dynamic voltage restorer (DVR) has become popular as a cost effective solution for the protection of sensitive loads from voltage sags and swells. A phase locked loop is used to keep the load voltage synchronized continuously and track the source voltage. It is shown that it improves the performance of the DVR, and also deals with modeling and simulation of a Dynamic Voltage Restore (DVR) for mitigation of voltage sags. From the simulations it can conclude that the series compensation technique is most reliable compared to shunt compensation as shunt compensation requires more reactive power to be

injected to the system for the same sags. And the energy storage required is also more for shunt compensation.

In [5], a single phase 1kvar SVC is Fabricated and Tested experimentally by connected to a SMSB Test System. The hardware of this SVC control system is developed based on Microcontroller LPC 2148 chip, the most modern industrial controller. Simulation analysis was done for the current with various firing angles and the results are presented. The harmonics increase with the increase in the firing angle. Experimentally it is found that it give very fast and precise compensation characteristics.

Here we introduce the various topologies for mitigation of voltage sag. The main objective is to online mitigation of voltage sag with the use of Static Var Compensator considering the three different conditions named as topologies and Booster Transformer, and its effectiveness in mitigating the voltage sag. Under the Static Var Compensator various topologies (combination of inductor, capacitor and triac) is used and results are plotted. From Static Var Compensator and Booster Transformer, the Comprehensive results are presented to assess the performance of each device to mitigate the voltage sag. This paper is organized as follows. Section II outlines the Background, Section III describes the methodology of mitigation of voltage sag, Section IV describes the experimental set up, Section V shows the graphical results for various cases considered separately and Section VI draws the conclusions.

## II. BACKGROUND

Power quality is simply the interaction of electrical power with electrical equipment. If electrical equipment operates correctly and reliably without being damaged or stressed, we would say that the electrical power is of good quality. On the other hand, if the electrical equipment malfunctions, is unreliable, or is damaged during normal usage, we would suspect that the power quality is poor [6].

Power quality is a collection of various subjects in terms of voltage quality, current quality, supply quality and consumption quality. It can be defined as: 'Any power problem manifested in voltage, current, or frequency deviations that result in failure or malfunction of customer equipment'. Poor power quality is often the main reason of unexplained equipment trips or shutdowns; occasional equipment damage or component failure; erratic control of process performance; random lockups and data errors, power system component overheating, etc. [14].

Problems of the quality of power delivered to the customers are an important issue due to the associated significant financial losses. They have also become an increasing concern for power suppliers because of the increasing demand of high quality of electricity supply. For manufacturers of electrical equipment, the disturbance ride through capability of their devices is an important point to win potential buyers [13].

Power quality is usually defined as anything that affects the voltage, current, and frequency of the power being supplied to the enduser, i.e., the ultimate user or consumer of electricity [10]. The most common types of voltage abnormalities are:

harmonics, voltage sags, voltage swells and short interruptions.

A Voltage Sag as defined by IEEE Standard 1159-1995, IEEE Recommended Practice for Monitoring Electric Power Quality, is a decrease in root mean square (RMS) voltage at the power frequency for durations from 0.5cycles to 1 minute. The magnitude of voltage sag lies between the 90% to 10% of nominal voltage.

### A. Classification of Voltage Sag

The voltage sag is further classified into two categories such as momentary and temporary voltage sag. This classification is based on time duration. Fig. 1 shows the definition of voltage magnitude events as used in IEEE standard 1159-1995 [8].

Momentary voltage sag is defined as the decrease in RMS voltage at a power frequency for duration from 0.5 cycles to 3 seconds. The magnitude of voltage sag event is between the 0.1pu to 0.9pu.

Temporary voltage sag is defined as the decrease in RMS voltage at a power frequency for duration from 3 seconds to 1 minute. The magnitude of voltage sag event is between the 0.1pu to 0.9pu.

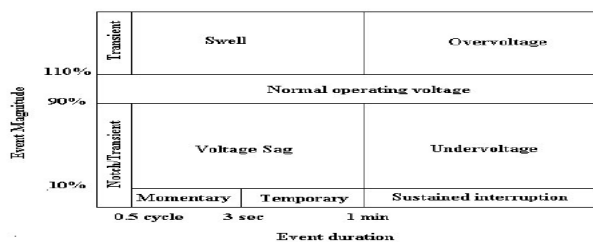

Fig. 1 Voltage Magnitude Events as used in IEEE Std. 1159-1995

If the voltage sag is persist for time duration more than 1 minute then it is called as Undervoltage. If the voltage swell is persist for time duration more than 1 minute then it is called as Overvoltage.

### B. Voltage Sag Characteristics

The three important Characteristics of voltage sag are: Magnitude (depth), Duration, and Phase angle jump [11].

#### 1. Magnitude (Depth)

One common practice is to characterize the sag magnitude through the remaining voltage during the sag, called as 'retained voltage'. The magnitude of voltage sag can be determined in number of ways. Most existing monitor obtains the sag magnitude from the RMS voltages. There are several ways of quantifying the voltage level. The obvious examples of the magnitude of the fundamental (power frequency) component of the voltage and the peak voltage are over each cycle or half cycle. The most monitor takes the lowest value. When the sag magnitude needs to be quantified in a number, one common practice is to characterize the sag through the remaining voltage during the sag. This is then given as percentage of the nominal voltage. Thus, a 70% sag in a 230 volt system means that the voltage dropped to 161V. This

method of sag characterizing the sag is recommended in number of IEEE standards (493-1998, 1159-1995 and 1346-1998).

Sag magnitude is defined as the remaining voltage during the event. Fig. 2 gives the magnitude duration plot. It shows that if the sag magnitude lies between the nominal operating voltages (90% to 110%) then according to definition of sag, there is no sag. The 85% sag indicates that only 15% reduction in RMS voltage from nominal voltage. Thus large magnitude sag indicates less severe is the event. The 30% sag indicates that 70% reduction in RMS voltage from nominal voltage. Thus, the small magnitude sag indicates more severe is the event. The opposite will be hold for the swell. This is the important characteristics of event for quantification of sag and swell event.

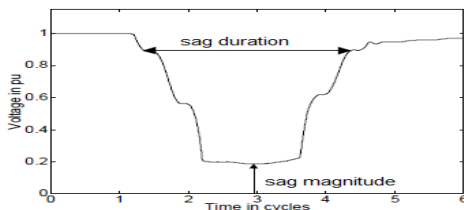

Fig. 2 Voltage sag Characteristics

## 2. Duration

Sag Duration is defined by the number of cycle during which the RMS voltage is below a given threshold. The typical value of threshold is around 90%. The start point of voltage sag is the instant at which the voltage falls below the 90% of the nominal voltage and the end point of the voltage sag is the instant at which the voltage rises above the 90% of the nominal voltage. The sag duration is the time between the start point and end point.

## 3. Phase Angle Jump

A short circuit in power system not only causes a drop in voltage magnitude but also a change in phase angle of the voltage. The Phase angle jump occurs due to different X/R ratio at the point of coupling. To obtain the phase angle of measured sag, phase angle of the voltage during the sag must be compared with the phase angle of the voltage before the sag. The phase angle of the voltage can be obtained from the voltage zero crossing or for the phase of fundamental component of the voltage.

A positive phase angle shift indicates that the phase angle of during event voltage leads the pre-event voltage. A negative phase-angle shift indicates that the phase angle of during-event voltage lags the pre-event voltage.

## III. METHODOLOGY

This paper introduces a new concept to investigate mitigation technique that is suitable for the voltage sag. Voltage sag has been the focus of considerable research in recent years. It can cause expensive downtime. The mitigation techniques are to be considered Static var compensator and

Booster transformer. The facts controller, triac and other power electronics devices is useful for the mitigation.

### A. Facts Controllers

FACTS (Flexible AC Transmission System) is defined as "a power electronic based system and other static equipment that provide control of one or more AC transmission system parameters to enhance controllability and increase power transfer capability." FACTS is a device used to control the governing parameters of the transmission line.

### B. Basic Types of Facts Controllers

- Series Controllers
- Shunt Controllers
- Combined series- series Controllers
- Combined series – shunt Controllers

### C. TRIAC

Triac can conduct in both directions of current flow whereas SCR can conduct in only in one direction. Thus triac is equivalent to two SCRs connected in antiparallel, hence called as Bidirectional Triode Thyristor. As it conducts in both directions, the term anode and cathode are not applicable. It has three terminals, namely A1, A2 and gate terminal. Due to which bidirectional conducting feature, it is operated with AC supply as semiconductor switch. It can be switched ON in both positive and negative half cycles. Fig. 3 shows the symbol of triac.

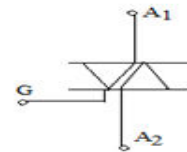

Fig. 3 Symbol of triac

From basic structure of triac, it is seen that, the region between terminals A1 and A2 is P-N-P-N ( $P_2 - N_1 - P_1 - N_4$ ) and with N-P-N-P ( $N_2 - P_2 - N_1 - P_1$ ). The terminal A1 is used as a reference for measuring currents and voltages and G and A2. Whatever may be the polarity of applied voltage between A2 and A1, the triac can be turned on by applying positive or negative gate pulse.

With AC voltage applied between A1 and A2, and with no gate signal, the triac blocks current in both half cycles, provided peak value of applied voltage is less than the breakover voltage  $V_{BO1}$  or  $V_{BO2}$ , the triac may be turned- on by breakdown of middle reverse biased junction. Therefore in order to retain gate control, peak value of applied voltage is must be less than breakover voltage. With gate current, triac can be turned on at applied voltage which is less than breakover voltage [16].

### Triggering modes of TRIAC:

Depending upon polarity of applied voltage and gate current, triac has four triggering modes:

- 1) A2 is positive and gate current is positive
- 2) A2 is positive and gate current is negative

- 3) A2 is negative and gate current is positive
- 4) A2 is negative and gate current is negative

*D. Static Var Compensator*

A Shunt connected static var generator or absorber whose output is adjusted to exchange capacitive or inductive current so as to maintain or control specific parameters of the electrical power system [12].

This is a general term for a thyristor-controlled or thyristor-switched reactor, and/or thyristor-switched capacitor or combination. SVC is based on thyristor without the gate turn-off capability. It includes separate equipment for leading and lagging vars; the thyristor-controlled or thyristor-switched reactor for absorbing reactive power and thyristor-switched capacitor for supplying the reactive power [15]. TRIAC is used from thyristor family. Triac can conduct in both directions (bi-directional device). By phase angle control of triac, the flow of current through the various topologies is varied. Hence by varying the firing angle alpha from 90 Deg. To 180 Deg., the conduction interval is reduced from maximum to zero [14]. Following are the 3 various new techniques discussed.

1. Topology 1

Fig. 4 shows the case of topology 1, inductor, triac and capacitor are in series combination, this combination may called as thyristor switched capacitor (TSC).

When the triac is closed and the TSC is connected to a sinusoidal ac voltage source  $v = V \sin \omega t$ , the current in the brunch is given by

$$i(\omega t) = V \frac{n^2}{n^2 - 1} \omega C \cos \omega t$$

where

$$n = \frac{1}{\sqrt{\omega^2 LC}} = \sqrt{\frac{X_c}{X_L}}$$

The switching off capacitors excites transients which may be large or small depending on the resonant frequency of the capacitors with the external system. The disconnected capacitor stays charged, so the voltage across the non-conducting triac varies between zero and peak to peak value of the applied ac voltage. When the capacitors voltage remains unchanged, the TSC bank can be switched in again, without any transient, at the appropriate peak voltage of the applied voltage. For positively charged capacitor the switching in is at positive peak of applied voltage, for negatively charged capacitor switching in is at negative peak of applied voltage. Usually, the capacitor bank is discharged after disconnection, therefore the reconnection can be done at some residual capacitor voltage.

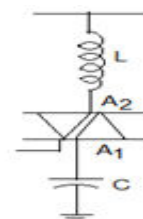

Fig. 4 Topology 1

The transient free conditions can be summarized as two simple rules. One, if the residual capacitor voltage is lower than the peak ac voltage, then the correct instant of switching is when the instantaneous ac voltage becomes equal to the capacitor voltage. Two, if the residual voltage of the capacitor is higher or equal to the peak ac voltage, then the correct switching is at the peak of ac voltage at which the thyristor valve voltage is minimum [15].

2. Topology 2

Fig. 5 shows the case of topology 2, SVC consists of inductor and triac are in series and capacitor is placed in parallel with this combination.

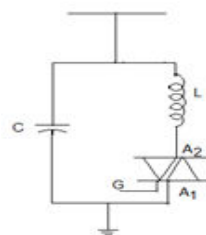

Fig. 5 Topology 2

When the amount of reactive power required to compensate the voltage in the ac power system connected to an SVC of the TCR-FC type is null, the TCR firing angle is adjusted so that the reactive power absorbed by the TCR fully offsets the fixed amount of reactive power supplied by the FCs. When the SVC has to supply reactive power to compensate the voltage in the ac power system (i.e., when the system absorbs reactive power), the TCR firing angle is increased so that the amount of reactive power absorbed by the TCR decreases. The lower the reactive power which the TCR absorbs, the higher the reactive power which the SVC supplies. When the TCR is set to the non conducting state, the amount of reactive power supplied by the SVC is maximal. The maximal amount of reactive power which an SVC of the TCR-FC type can supply is equal to the reactive power rating (i.e.  $Q_C$ ) of the FCs. The magnitude of the SVC is inductive admittance  $B_L(\alpha)$  is a function of the firing angle  $\alpha$  and is given as

$$B_L(\alpha) = \frac{2\pi - 2\alpha + \sin 2\alpha}{\pi X_s} \tag{1}$$

where  $\frac{\pi}{2} \leq \alpha \leq \pi, X_s = \frac{V_s^2}{Q_L}$

$V_s$  is SVC bus bar voltage and  $Q_L$  is rating of reactor. As the SVC uses a fixed capacitor and variable reactor combination, the effective shunt admittance is

$$B_s = \frac{1}{X_c} - B_L(\alpha) \quad (2)$$

Conversely, when the SVC has to absorb reactive power to compensate the voltage in the ac power system (i.e., when the system supplies reactive power), the TCR must absorb enough reactive power to, firstly, fully offset the fixed amount of reactive power supplied by the FCs, and, secondly, absorb enough extra reactive power to compensate for the reactive power supplied by the ac power system connected to the SVC. This means that the power rating of the TCR in an SVC of the TCR-FC type needs to be higher than that of the FCs, otherwise, the SVC would not be able to absorb reactive power from the ac power system to which it is connected.

### 3. Topology 3

Fig. 6 shows the case of topology 3, SVC consists of capacitor and triac are in series and inductor is placed in parallel with this combination

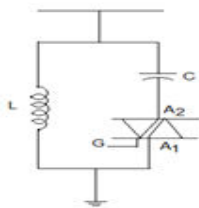

Fig. 6 Topology 3

The TSCs of an SVC can only be switched in or switched out. Because of this, the amount of reactive power supplied by the TSCs can only be adjusted by steps by changing the number of TSCs that are switched in at the same time. The higher the number of TSCs that are switched in, the higher the amount of reactive power supplied by the TSCs. The TCR, on the other hand, can be adjusted as needed from a full-conducting state (TCR firing angle  $\_ 90^\circ$ ) to a non-conducting state (TCR firing angle  $\_ 180^\circ$ ), thereby allowing precise and continuous adjustment of the amount of reactive power which the SVC exchanges with the ac power system to which it is connected.

### E. Booster Transformer

When sag occurs in the system, the Booster transformers calculates and synthesizes the voltage required to maintain output voltage to the load by injecting a controlled voltage with a certain magnitude and phase angle into the system to the critical load. During voltage sag, the booster transformer injects a voltage to restore the load supply voltages.

From Fig. 7, when booster transformer connected in online process, the supply voltage is continuously monitored and compared with a reference voltage; if the difference exceeds a certain tolerance, the booster transformer injects the required

voltage. When the polarity of booster transformer is changed, it causes voltage swell.

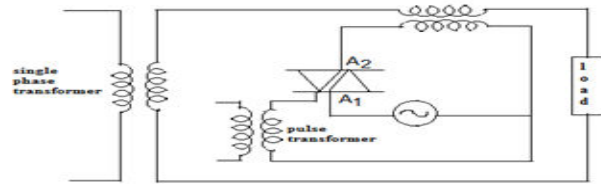

Fig. 7 Booster transformer  
(Circuit diagram connection only for voltage sag)

### F. Control Schemes

The fuzzy logic control is being proposed for controlling the voltage sag.

#### 1. Fuzzy Logic Control

In fuzzy logic, basic control is determined by a set of linguistic rules which are determined by the system. Since numerical variables are converted into linguistic variables, mathematical modeling of the system is not required. A Mamdani fuzzy linguistic controller has been designed to regulate the voltage sag. Unlike Boolean logic, fuzzy logic allows states (membership values) between 0 or 1. Its major features are the use of linguistic variables rather than numerical variables. Linguistic variables, defined as variables whose values are sentences in a natural language (such as small and big), may be represented by fuzzy sets [18]. The general structure of an FLC is represented in Fig. 8 and comprises four principal components:

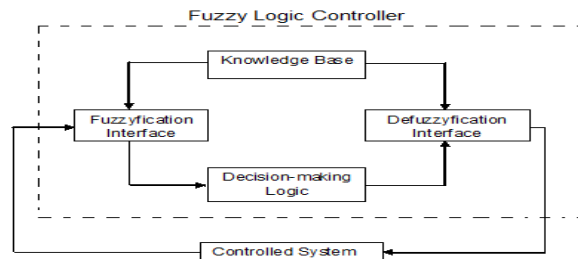

Fig. 8 Basic configuration of FL controller

- A fuzzyfication interface which converts input data into suitable linguistic values;
- A knowledge base which consists of a data base with the necessary linguistic definitions and control rule set;
- A decision making logic which, simulating a human decision process, infers the fuzzy control action from the knowledge of the control rules and the linguistic variable definitions; and
- A defuzzyfication interface which yields a nonfuzzy control action from an inferred fuzzy control action.

Fuzzy logic controller is designed to achieve the firing angles for SVC such that it maintains voltage profile [17]. In the decision-making process, there is rule base that linking

between input and output signal. Figs. 9 & 10 shows the input and output variables. When the error voltage ( $V_{pu} - V_{base\ pu}$ ) is small, firing angle is large. The rule bases used in this FL controller are:

1. if (input1 is mf1) then (output1 is mf3)
2. if (input1 is mf2) then (output1 is mf2)
3. if (input1 is mf3) then (output1 is mf1)

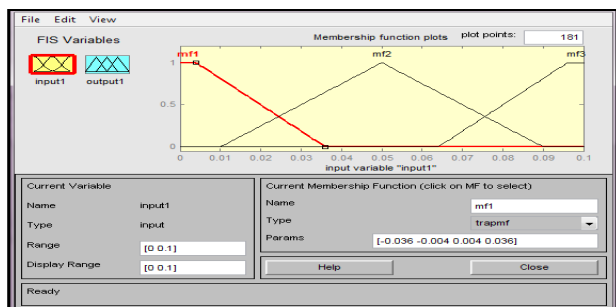

Fig. 9 Input variables

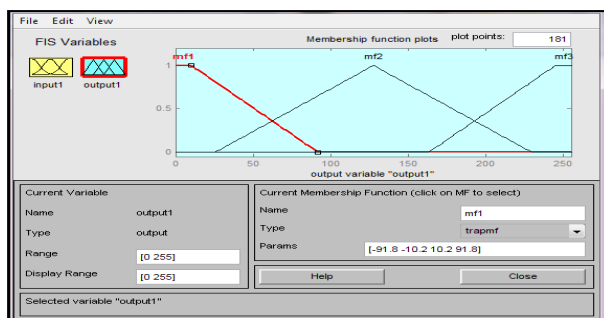

Fig. 10 Output variables

#### IV. EXPERIMENTAL SETUP

To study the online performance of the mitigation technique, voltage sag is generated in the laboratories through tailor made experimentation setup. Desired voltage signals are captured through data acquisition card and processed through mitigation. This paper describes the hardware used during the experimentation.

Fig. 11 shows the practical experimental setup that was used to conduct the experiment in laboratory. The main components required for the setup are: single phase transformer, single phase induction motor, pulse transformer, gain control circuit, Zero crossing detector, Advantech data acquisition card, BASYS2 kit, personnel computer etc. The induction motor was used as a load. The block diagram of Experimental setup for study is shown in Fig. 12.

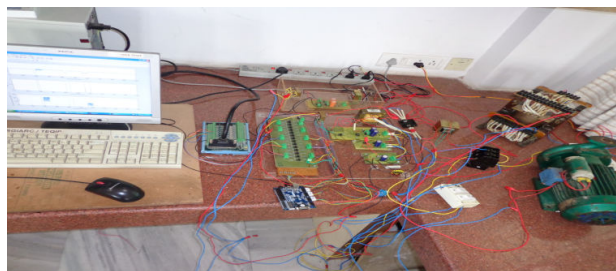

Fig. 11 Practical Experimental setup

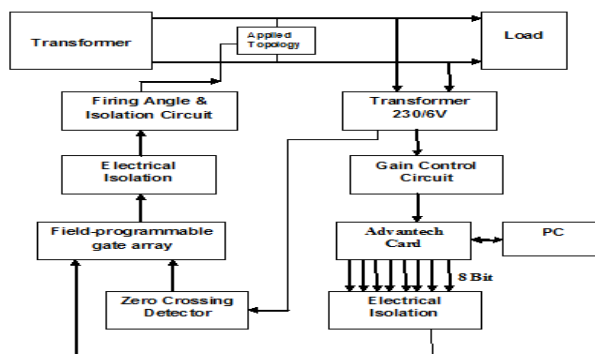

Fig. 12 Block diagram of Experimental setup

In experimentation, single phase 2KVA, 230V/230V, isolation transformer is used. It has taps that can be set from 0V to 230V in steps of 10V. Change of taps can be viewed as voltage sag conditions for online simulation. To create induction motor of 2hp is used as a load which act as source of voltage sag. A step down transformer of 230/6V is used as potential transformer to provide the signal of desired magnitude for the measurement purpose.

The gain control circuit is necessary to prevent the clamping of input voltage signal and also to provide the isolation between the computer and the supply. The gain 0.5 is achieve by choosing the values of  $R_f = 5K\Omega$  and  $R_1 = 10K\Omega$ . The input voltage at the op-amplifier is 6V and voltage available at the output is 3V. The rising edge of Zero Crossing Detector is used to measure the firing angle  $\alpha$ . The Diligent BASYS 2 kit is used for the firing angle control.

In experimentation, mitigation of the voltage sag using Static Var Compensator and Booster transformer is used. Under these categories, different topologies (combination of triac, inductor, capacitor) is used and results are plotted. In this way describes the practical experimental setup developed in the laboratory to mitigate the voltage sag. This experimental setup is used for online mitigation of voltage sag, for different methodology using MATLAB program.

#### V. RESULTS AND DISCUSSIONS

In this section describe the results obtained from online mitigation of voltage sag. The objective is to mitigate the voltage sag up to 1pu voltage (nominal voltage).

As per the definition of voltage sag, decrease in rms voltage from 0.9 to 0.1pu but in this paper, regulation of the sag in between 0.9 to 1pu is also done.

The voltage sag signal was captured at 198V tapping and also with starting of an induction motor, by considering with and without compensation technique. For without compensation technique no mitigation proposed methods and for with compensation technique SVC and Booster transformer mitigation methods are considered.

These following cases are studied for the mitigation of voltage sag using various methods.

*A. Discussions on Mitigation of Voltage Sag*

Online monitoring system for voltage sag mitigation in the laboratory using the hardware mentioned chapter 4. For both Static Var Compensator and Booster Transformer developed for each method provide mitigation of the voltage sag. Due to space limitations, figure shown only anyone instance and in

tabular form shows the various instance results. The results are discussed below:

*B. Static Var Compensator*

The voltage sag is created using starting of an induction motor and also by tap changing of transformer. These two different cases are mentioned that (With/without compensation in case of induction motor and With/without compensation in case of tap changing of transformer). The sag flag denotes the detection of voltage sag and graph of firing angle shows the firing angle signal. As soon as the voltage sag detects, firing angle is changed as per sag and try to regulate voltage sag upto 1pu.

1. Topology 1

Captured signal due to induction motor starting for instance 1 are shown in Fig. 13.

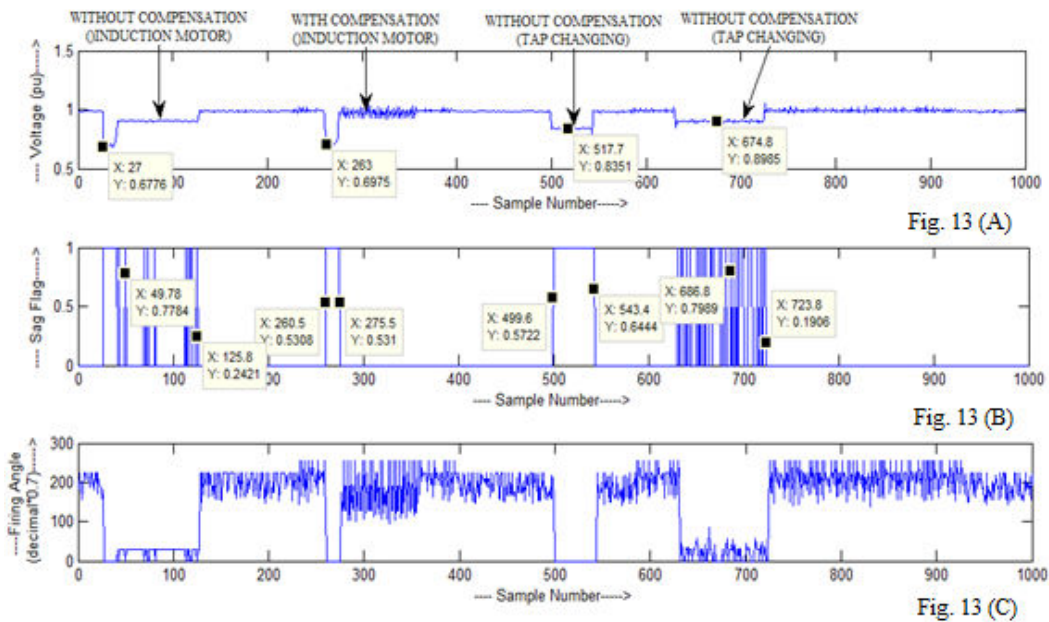

Fig.13 Online Mitigation of Voltage Sag Due to Induction Motor Starting Using Topology 1 (INSTANCE 1)

The depth of sag for without compensation in case of sag due to starting of induction motor is 0.6776pu and depth of sag for with compensation is 0.6975, shown in Fig. 13 (A). The duration of sag for without compensation technique is 76 cycles and for with compensation technique, duration of sag is of 15 cycles, shown in Fig. 13 (B). Fig. 13 (C) shows that firing angle is changed as per sag and try to regulate voltage sag up to 1pu.

By taking first 20 samples of voltage sag for without compensation and with compensation is plotted, shown in Fig. 14. This shows that, in case of with compensation technique voltage sag is mitigated.

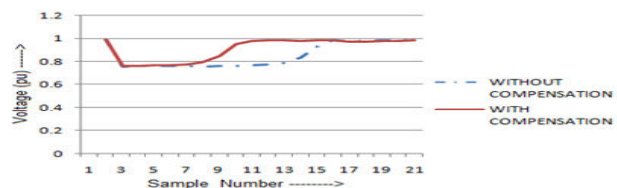

Fig. 14 Voltage Sag Due to Induction Motor Starting Graph Plotted With Verses Without Compensation Technique Using Topology 1 (INSTANCE 1)

The snapshots of the online monitoring systems under switching instance due to tap changing are given in Fig. 15.

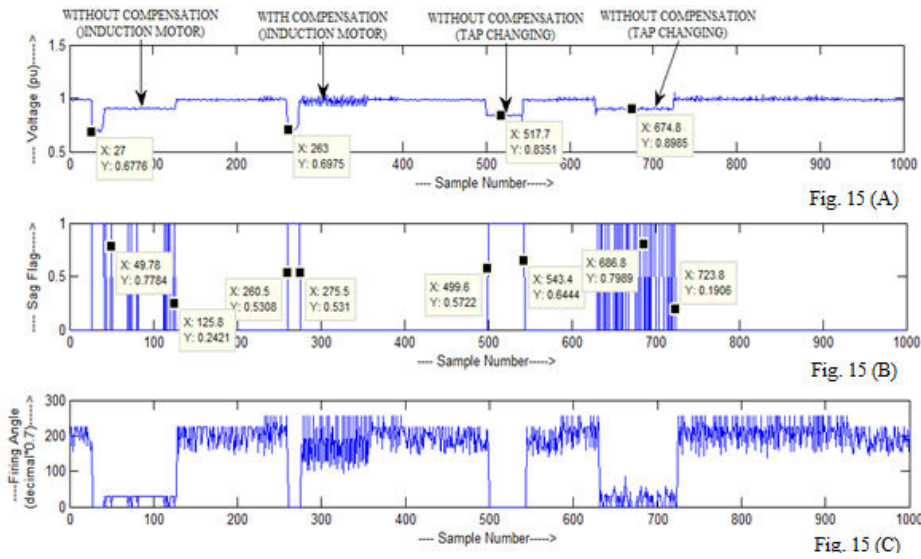

Fig. 15 Online Mitigation of Voltage Sag Due to Tap Changing Transformer Using Topology 1 (INSTANCE 1)

The depth of sag for without compensation in case of sag due to starting of induction motor is 0.851814865pu and depth of sag for with compensation is 0.8586411975pu, shown in Fig. 15 (A). The duration of sag for without compensation technique is 44 cycles and for with compensation technique, duration of sag is of 37 cycles, shown in Fig. 15 (B). Fig. 15 (C) shows that firing angle is changed as per sag and try to regulate voltage sag up to 1pu.

By taking first 20 samples of voltage sag for without compensation and with compensation is plotted, shown in Fig. 16. This shows that, in case of with compensation technique voltage sag is mitigated.

2. Topology 2

Captured signal due to induction motor starting for instance 1 are shown in Fig. 17.

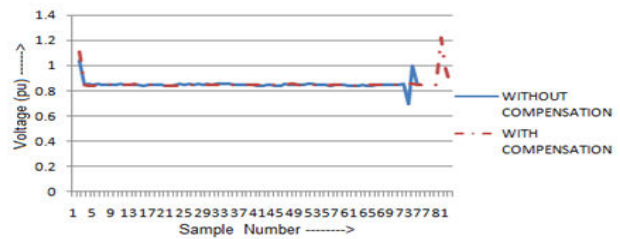

Fig. 16 Voltage Sag Due to Tap Changing Transformer Graph Plotted With Verses Without Compensation Technique Using Topology 1 (INSTANCE 1)

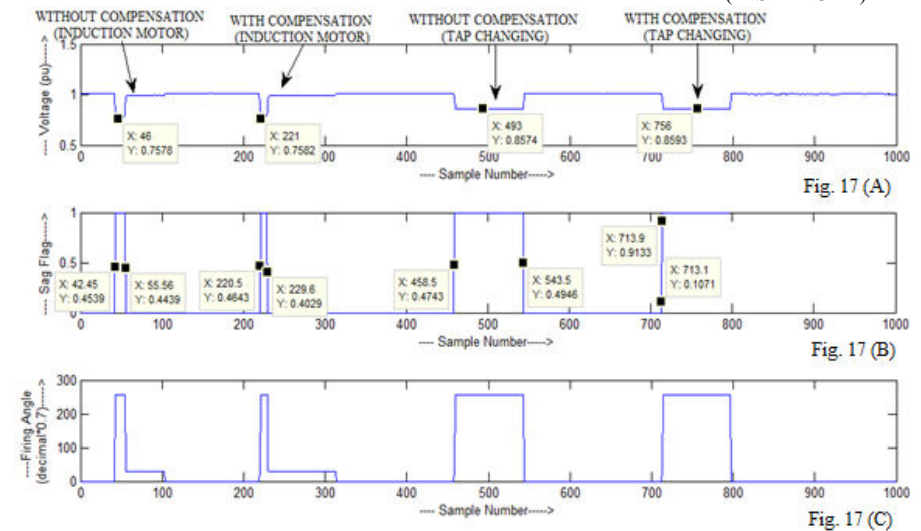

Fig. 17 Online Mitigation of Voltage Sag Due to Induction Motor Starting Using Topology 2 (INSTANCE 1)

The depth of sag for without compensation in case of sag due to starting of induction motor is 0.7576pu and depth of sag for with compensation is 0.7582, shown in Fig. 17 (A).

The duration of sag for without compensation technique is 13 cycles and for with compensation technique, duration of sag is of 9 cycles, shown in Fig. 17 (B). Fig. 17 (C) shows that firing



angle is changed as per sag and try to regulate voltage sag up to 1pu.

By taking first 20 samples of voltage sag for without compensation and with compensation is plotted, shown in Fig. 18. This shows that, in case of with compensation technique voltage sag is mitigated up to some extent.

The snapshots of the online monitoring systems under switching instance due to tap changing are given in Fig. 19.

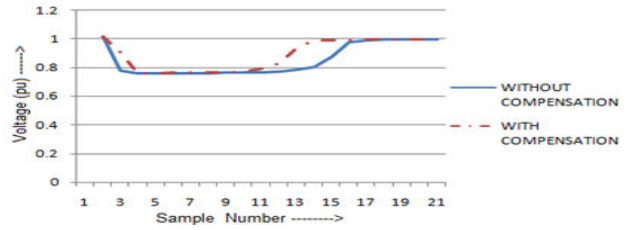

Fig. 18 Voltage Sag Due to Induction Motor Starting Graph Plotted With Verses Without Compensation Technique Using Topology 2 (INSTANCE 1)

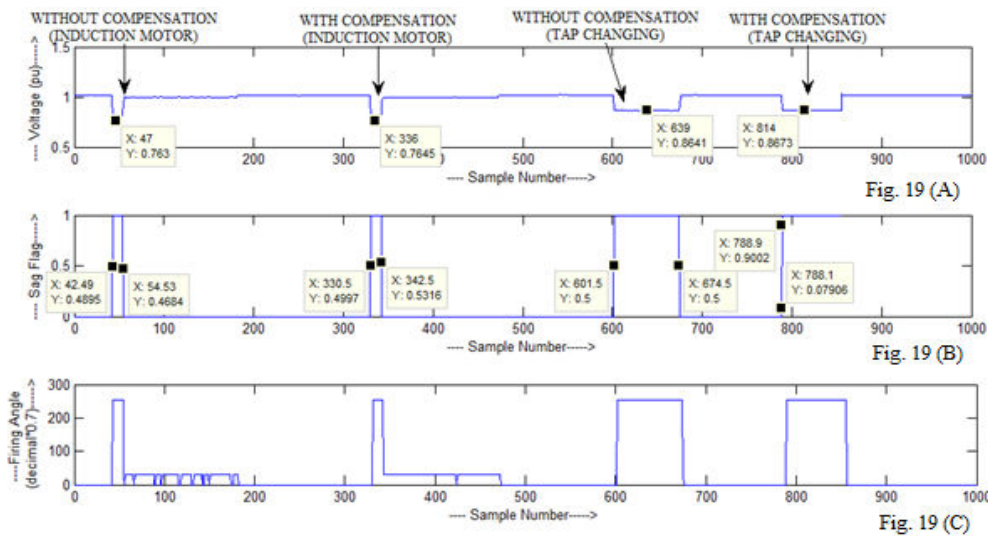

Fig. 19 Online Mitigation of Voltage Sag Due to Tap Changing Transformer Using Topology 2 (INSTANCE 1)

The depth of sag for without compensation in case of sag due to starting of induction motor is 0.868257895pu and depth of sag for with compensation is 0.870307246pu, shown in Fig. 19 (A). The duration of sag for without compensation technique is 73 cycles and for with compensation technique, duration of sag is of 0.8 cycles, shown in Fig. 19 (B). Fig 19 (C) shows that firing angle is changed as per sag and try to regulate voltage sag upto 1pu.

20. This shows that, in case of with compensation technique voltage sag is mitigated upto some extend.

### 3. Topology 3

Captured signal due to induction motor starting for instance 1 are shown in Fig. 21.

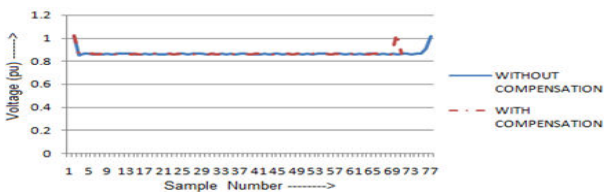

Fig. 20 Voltage Sag Due to Tap Changing Transformer Graph Plotted With Verses Without Compensation Technique Using Topology 2 (INSTANCE 1)

By taking first 20 samples of voltage sag for without compensation and with compensation is plotted, shown in Fig.

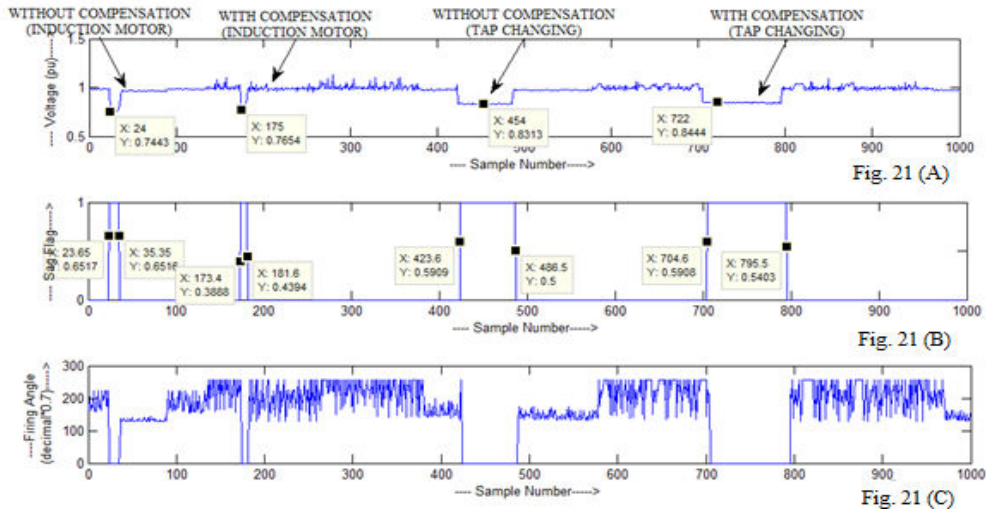

Fig. 21 Online Mitigation of Voltage Sag Due to Induction Motor Starting Using Topology 3 (INSTANCE 1)

The depth of sag for without compensation in case of sag due to starting of induction motor is 0.7443pu and depth of sag for with compensation is 0.7654pu, shown in Fig. 21 (A). The duration of sag for without compensation technique is 11.7 cycles and for with compensation technique, duration of sag is of 8.2 cycles, shown in Fig 21 (B). Fig. 21 (C) shows that firing angle is changed as per sag and try to regulate voltage sag upto 1pu.

By taking first 20 samples of voltage sag for without compensation and with compensation is plotted, shown in Fig. 22. This shows that, in case of with compensation technique voltage sag is mitigated upto some extent.

The snapshots of the online monitoring systems under switching instance due to tap changing are given in Fig. 23.

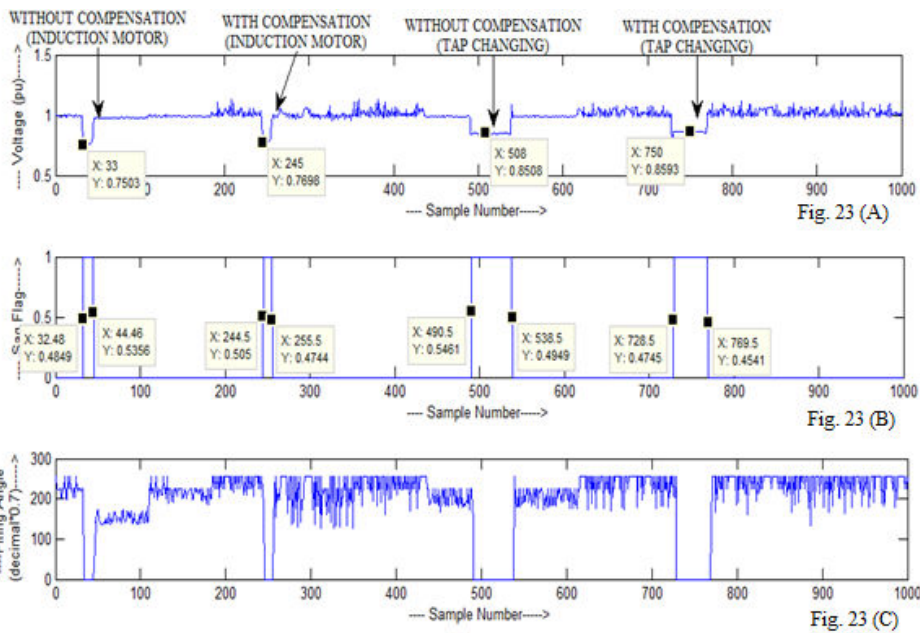
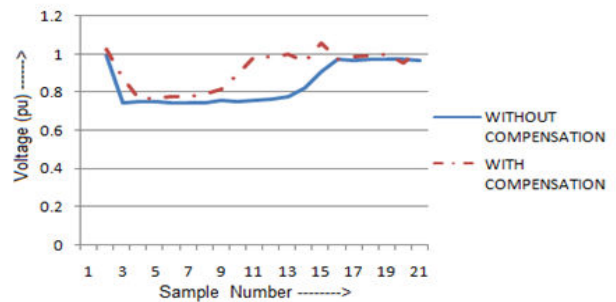

Fig. 23 Online Mitigation of Voltage Sag Due to Tap Changing Transformer Using Topology 3 (INSTANCE 1)

The depth of sag for without compensation in case of sag due to starting of induction motor is 0.849882143pu and depth of sag for with compensation is 0.872896491pu, shown in Fig. 23 (A). The duration of sag for without compensation technique is 48 cycles and for with compensation technique, duration of sag is of 41 cycles, shown in Fig. 23 (B). Fig. 23 (C) shows that firing angle is changed as per sag and try to regulate voltage sag upto 1pu.

By taking first 20 samples of voltage sag for without compensation and with compensation is plotted, shown in Fig. 24. This shows that, in case of with compensation technique voltage sag is mitigated upto some extend.

*C. Booster Transformer*

The voltage sag is created using starting of an induction motor and also by tap changing. The sag flag denotes the detection of voltage sag and graph of firing angle shows the firing angle signal. As soon as the voltage sag detects, firing

angle is changed as per sag and try to regulate voltage sag upto 1pu.

Captured signal due to induction motor starting for instance 1 are shown in Fig. 25.

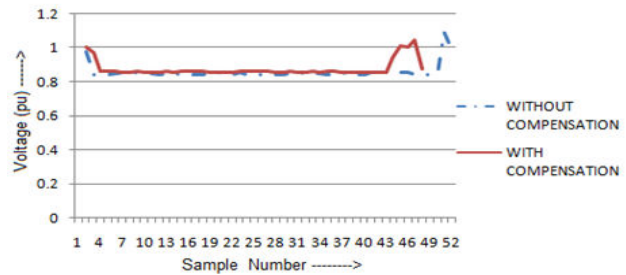

Fig. 24 Voltage Sag Due to Tap Changing Transformer Graph Plotted With Verses without Compensation Technique Using Topology 3

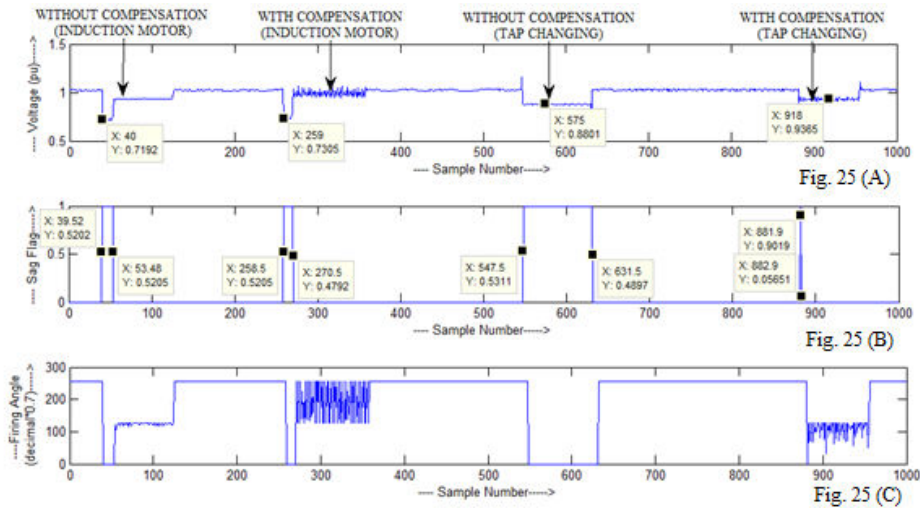

Fig. 25 Online Mitigation of Voltage Sag Due to Induction Motor Starting Using Booster Transformer Topology (INSTANCE 1)

The depth of sag for without compensation in case of sag due to starting of induction motor is 0.7192pu and depth of sag for with compensation is 0.7305pu, shown in Fig. 25 (A). The duration of sag for without compensation technique is 13.96 cycles and for with compensation technique, duration of sag is of 12 cycles, shown in Fig. 25 (B). Fig. 25 (C) shows that firing angle is changed as per sag and try to regulate voltage sag upto 1pu.

By taking first 20 samples of voltage sag for without compensation and with compensation is plotted, shown in Fig. 26. This shows that, in case of with compensation technique voltage sag is mitigated.

The snapshots of the online monitoring systems under switching instance due to tap changing are given in Fig. 27.

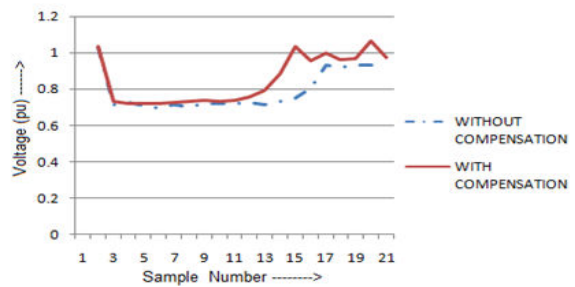

Fig. 26 Voltage Sag Due to Induction Motor Starting Graph Plotted With Verses without Compensation Technique Using Booster Transformer Topology (INSTANCE 1)

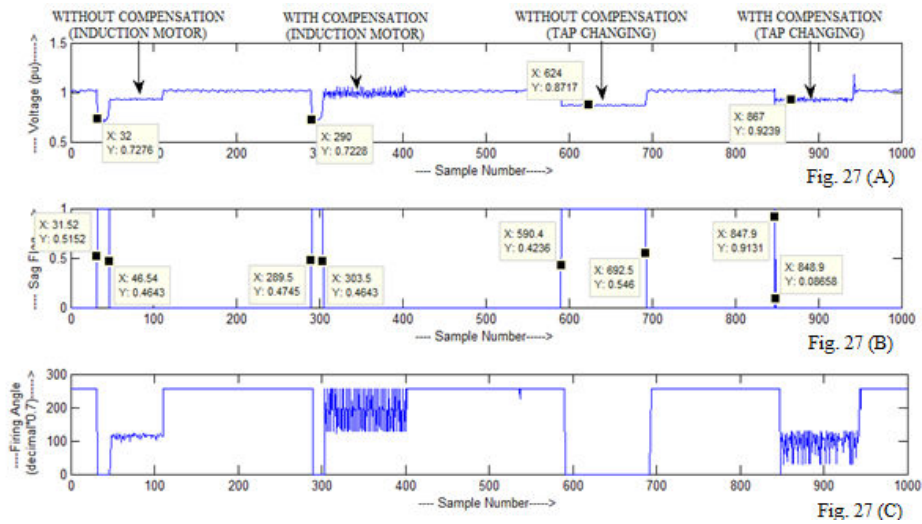

Fig. 27 Online Mitigation of Voltage Sag Due to Tap Changing Transformer Using Booster Transformer Topology (INSTANCE 1)

The depth of sag for without compensation in case of sag due to starting of induction motor is 0.844509278pu and depth of sag for with compensation is 0.910271795pu, shown in Fig. 27 (A). The duration of sag for without compensation technique is 102.1 cycles and for with compensation technique, duration of sag is of 1 cycle, shown in Fig. 27 (B). Fig. 27 (C) shows that firing angle is changed as per sag and try to regulate voltage sag up to 1pu.

By taking first 20 samples of voltage sag for without compensation and with compensation is plotted, shown in Fig. 27. This shows that, in case of with compensation technique voltage sag is mitigated.

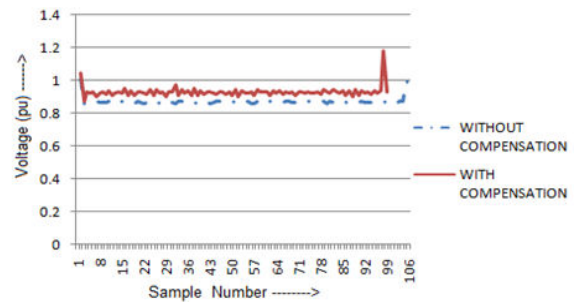

Fig. 28 Voltage Sag Due to Tap Changing Transformer Graph Plotted With Verses without Compensation Technique Using Booster Transformer Topology (INSTANCE 1)

TABLE I  
DEPTH AND DURATION OF VOLTAGE SAG IN CASE OF INDUCTION MOTOR STARTING

Various Instance	Depth Of Sag		Duration Of Sag	
	Without Compensation	With Compensation	Without Compensation	With Compensation
<b>SVC (TOPOLOGY 1)</b>				
INSTANCE 1	0.7695	0.7714	12	7
INSTANCE 2	0.7245	0.7309	15	6
INSTANCE 3	0.6776	0.6975	76	15
<b>SVC (TOPOLOGY 2)</b>				
INSTANCE 1	0.7576	0.7582	13	9
INSTANCE 2	0.763	0.7645	12.4	12
INSTANCE 3	0.7557	0.7576	11.91	10.08
<b>SVC (TOPOLOGY 3)</b>				
INSTANCE 1	0.739	0.7589	13.05	12
INSTANCE 2	0.7443	0.7654	11.07	8.02
INSTANCE 3	0.7497	0.7661	13.12	9.01
<b>BOOSTER TOPOLOGY</b>				
INSTANCE 1	0.7023	0.7056	127.82	30
INSTANCE 2	0.7073	0.7056	72.59	9.9
INSTANCE 3	0.7192	0.7305	13.96	12

TABLE II  
DEPTH AND DURATION OF VOLTAGE SAG IN CASE OF TAP CHANGING TRANSFORMER

Various Instance	Depth Of Sag		Duration Of Sag	
	Without Compensation	With Compensation	Without Compensation	With Compensation
<b>SVC (TOPOLOGY 1)</b>				
1	0.851814865	0.8586411975	44	37
2	0.859381395	0.863514286	40	38
3	0.863461538	0.868315663	51	1
<b>SVC (TOPOLOGY 2)</b>				
1	0.868257895	0.870307246	73	0.8
2	0.855403222	0.856822353	88	0.8
3	0.864167045	0.858034118	85	0.8
<b>SVC (TOPOLOGY 3)</b>				
1	0.849882143	0.872896491	48	41
2	0.854933333	0.876484783	53.8	50.8
3	0.846807595	0.860975	77	124
<b>BOOSTER TOPOLOGY</b>				
1	0.844509278	0.910271795	102.1	1
2	0.8704114299	0.928343299	66.7	0.8
3	0.87796571	0.935829825	93.9	0.8

TABLE III  
INDUCTION MOTOR

Mitigation Methods	Without Compensation (Pu)	With Compensation (Pu)	Sag Mitigation (Pu)	Sag Mitigation (%)
<b>STATIC VAR COMPENSATOR</b>				
TOPOLOGY 1	0.865375	0.90786	0.042485	4.679
	0.852375	0.90806	0.055385	6.099
	0.85792	0.916545	0.058625	6.396
TOPOLOGY 2	0.851965	0.887615	0.03565	4.016
	0.860705	0.86076	0.000055	0.0063
	0.855035	0.875185		
TOPOLOGY 3	0.83299	0.855715	0.022725	2.6556
	0.840425	0.92256	0.082135	8.9029
	0.8389645	0.898245	0.0592805	6.5995
<b>BOOSTER TRANSFORMER</b>				
TOPOLOGY	0.79256	0.84786	0.0553	6.5223
	0.758015	0.781645	0.02363	3.0231
	0.74309	0.849255	0.106165	12.5009

TABLE IV  
TAP CHANGING

Mitigation Methods	Without Compensation (Pu)	With Compensation (Pu)	Sag Mitigation (Pu)	Sag Mitigation (%)
<b>STATIC VAR COMPENSATOR</b>				
TOPOLOGY 1	0.851814865	0.8586411975	0.006827114	0.755
	0.859381395	0.863514286	0.004132891	0.478
	0.863461538	0.868315663	0.004854125	0.559
TOPOLOGY 2	0.868257895	0.870307246	0.002049351	0.235
	0.855403222	0.856822353	0.001419131	0.0016
	0.864167045	0.858034118	-	-
TOPOLOGY 3	0.849882143	0.872896491	0.02314348	2.636
	0.854933333	0.876484783	0.02155145	2.458
	0.846807595	0.860975	0.014167405	1.64
<b>BOOSTER TRANSFORMER</b>				
TOPOLOGY	0.844509278	0.910271795	0.065762517	7.224
	0.870411429	0.928343299	0.05793187	6.240
	0.877965714	0.935829825	0.057864111	6.183

It can be observed that from Tables I and II, in both cases of voltage sag due to induction motor starting and tap changing transformer, depth of voltage sag is lower in without compensation technique than in with compensation technique

for all proposed methods. This shows that by using compensation technique (with proposed mitigation topology), sag is mitigated. Also duration of sag is drops down by using mitigation technique.

From Tables III and IV, it can be seen that (by taking first 20 samples of sag in both with and without compensation technique), by using proposed methodology sag is mitigated.

## VI. CONCLUSIONS

In this paper, mitigation of the voltage sag using Static Var Compensator and Booster transformer is used. Under these categories, different topologies (combination of triac, inductor, capacitor) is used and results are plotted. In this way describes the practical experimental setup developed in the laboratory to mitigate the voltage sag. This experimental setup is used for online mitigation of voltage sag, for different methodology using MATLAB program.

The hardware of this SVC control system is developed based on FPGA. Result analysis was done for the Static var compensator and Booster Transformer with various conditions and the results are presented. Booster Transformer give the better result than Static var compensator. The proposed model is experimentally verified and is found to give very fast and precise compensation characteristics.

## REFERENCES

- [1] P. Wang Student Member IEEE, N. Jenkins Senior Member IEEE, M.H.J.Bollen "Experimental investigation of voltage sag mitigation by an advanced static var compensator" IEEE Transactions on Power Delivery, Vol. 13, No. 4, October 1998 1461.
- [2] Taufik and Bryan Paet, "A small scale static var compensator for laboratory Experiment" 2nd IEEE International Conference on Power and Energy (PECon 08), December 1-3, 2008, Johor Baharu, Malaysia,
- [3] Venu Yarlagadda, B. V. Sankar Ram and K. R. M. Rao, "Testing and Control of TSC-TCR Type Static Var Compensator (SVC) Using Microcontroller" (International Journal of Control and Automation Vol. 5, No. 3, September, 2012.
- [4] Nagendrababu Vasa, sreekanth G, Narender Reddy Narra, Dr. Srujana A, "Series Compensation Technique for Voltage Sag Mitigation", IOSR Journal of Engineering (IOSRJEN) ISSN: 2250-3021 Volume 2, Issue 8 (August 2012), PP 14-2
- [5] Venu Yarlagadda, K. R. M. Rao & B. V. Sankar Ram "Hardware Circuit Implementation of Automatic Control of Static Var Compensator (SVC) using Micro Controller" International Journal of Instrumentation, Control and Automation (IJICA) ISSN : 2231-1890 Volume-1, Issue-2, 2011
- [6] M.H.J.BOLLEN, "Understanding power Quality Problems Voltage sags and interruptions". New York IEEE press,1999,Vol.I
- [7] M.H.J.BOLLEN, " Signal Processing of power Quality Disturbances"
- [8] IEEE Std.1159-1995, "IEEE Recommended Practice for Monitoring Electric Power Quality"
- [9] Roger C Dugan, " Electrical Power systems Quality" second edition.
- [10] Barry W Kennedy "Power Quality Primer"
- [11] Roberto Chouhy Leborgne "Thesis for the Degree of Doctor of Philosophy" Voltage Sags: Single event characterization, system performance and source location
- [12] Y.Zhang and J. V. Milanović, "Optimal Placement of FACTS Devices for Voltage.
- [13] "Sag Mitigation Based on Genetic Algorithms", CD ROM of the 12th IEEE International Conference on Harmonics and Quality of Power, ICHQP 2006,Cascais, Portugal, October 1-5, 2006.
- [14] Technical report on " Techno-economic Assessment of Voltage Sag Performance and Mitigation" A Thesis submitted to The University of Manchester for the degree of PhD in the Faculty of Engineering and Physical Sciences 2008 Yan Zhang, B.Sc., M.Sc. School of Electrical and Electronic Engineering
- [15] Narain G. Hingorani, Laszlo Gyugyi "Understanding FACTS", Concepts and Technology Of Flexible AC Transmission Systems.
- [16] Deodatta Singare, "Power Electronics"
- [17] S.Ezhilarasan, G.Balasubramanian,"Dynamic Voltage Restorer For Voltage Sag Mitigation Using Pi With Fuzzy Logic Controller"

International Journal of Engineering Research and Applications (IJERA) ISSN: 2248-9622 www.ijera.com Vol. 3, Issue 1, January -February 2013, pp.1090-1095

- [18] Y. Hoseynpoor, T.PirzadehAshraf, Sh. Sajedi, T. Karimi, " Fuzzy Logic Based Control of Static Var Compensator, Australian Journal of Basic and Applied Sciences, 5(6): 987-995,2011 ISSN 1991-8178.



**Vijay Gajanan Neve** born at Khamgaon [M.S.] India, dated 31/08/1972. He received the B.E. degree in Electrical Engineering and the M.E degree in Electrical Power System Engineering from the Amravati university Amravati, INDIA, in 1994 and 2000, respectively.

Currently, he is pursuing the Ph.D. degree in power quality from the Shri Santa Gajanan Maharaj College of engineering, Shegaon (M.S) INDIA, under Amravati university. He is currently working as a ASSOC. Professor & Head of Electrical Engineering Department at Jagadambha College of Engineering & Technology, Yavatmal (M.S.), INDIA, since 2010 to till date. Previously he has worked as a lecturer / Sr.lecturer in Jawaharlal Darda Institute of Engineering & Technology Yavatmal (M.S.), INDIA, from 2002 to 2010. His research area include Power System, General Electrical Engg., power quality, etc. He was awarded "Certificate of Merit" for paper publication in the journal of Institution of Engineers, (IEE) in 2004. He is the member in editorial board of the international journal IJCETS and IJCES, which issues their Publication twice in the year and also worked as a Regional Co-ordinator for the International Journal. He is life member of ISTE..



**Pallavi Vilas Pullawar** received the B.E. degree in Electrical Engineering and the M.E degree appearing in Electrical Power System Engineering from the Amravati university Amravati, INDIA.

She is currently working as a Lecturer at Jagadambha College of Engineering & Technology, Yavatmal (M.S.), INDIA,



**Dr. Gajanan M. Dhole** received the B.E. degree in Electrical Engineering in 1990, from the Amravati university, Amravati, & M.Tech from Nagpur university, Nagpur, in 1992, and the PhD degree from the Amravati university, Amravati, INDIA, all in electrical engineering.

Currently, he is an Professor of electrical engineering department at Shri Santa Gajanan Maharaj College of engineering, Shegaon (M.S) INDIA, since 1992 to till date. His research area includes power system, Digital Signal Processing, Embedded System etc. He was awarded "Certificate of Merit" for paper publication in the journal of Institution of Engineers, (IEE) in 2004. He is the members in many editorial boards of the international journals.