

Microcontroller Based EOG Guided Wheelchair

Jobby K. Chacko, Deepu Oommen, Kevin K. Mathew, Noble Sunny, N. Babu

Abstract—A new cost effective, eye controlled method was introduced to guide and control a wheel chair for disable people, based on Electrooculography (EOG). The guidance and control is effected by eye ball movements within the socket. The system consists of a standard electric wheelchair with an on-board microcontroller system attached. EOG is a new technology to sense the eye signals for eye movements and these signals are captured using electrodes, signal processed such as amplification, noise filtering, and then given to microcontroller which drives the motors attached with wheel chair for propulsion. This technique could be very useful in applications such as mobility for handicapped and paralyzed persons.

Keywords—Electrooculography, Microcontroller, Signal processing, Wheelchair.

I. INTRODUCTION

PRESENT industry is shifting towards automation by using Programmable controllers and robots in industrial automation. Today's life, there is a need to develop an intelligent system to serve the mankind. People with physical disabilities face a lot of problems for mobility and new devices with sophisticated technologies are needed to help them for comfortable mobility. Various types of research groups at a world level have begun to set up cooperation projects, projects to aid communication and mobility of elderly and/or disabled persons with the aim of increasing their quality of life and allowing them a more autonomous and independent lifestyle and greater chances of social integration [1], [2]. In recent years, the applications for developing systems to help people with several disabilities have been increased. The ability of people to control their gaze direction can be used for mobility with use of wheel chairs. There are many applications developing help systems to people with several disabilities. They are videooculography systems (VOG) or infrared oculography (IROG) based on detect the eye position using a camera [3]. Many systems have been produced in communication from machines to human hands using keyboard, mouse, joy sticks, and touching screen etc. But all these need normal human hands to operate. For physically challenged peoples with paralyzed muscles and not having normal functions of hand, these techniques will not help.

EOG based wheel chair system is one of the popular techniques for physically disabled. Many research papers have

published for various types of wheel chairs based on eog signals. Robotic wheel chair system [4], eye movement based human computer interaction technique [5], EOG guidance using neural network [6], head mounted eye –gaze input interfaces [7] and stereo vision based wheel chair [8] etc.

These are all highly sophisticated techniques and expensive. We have tried a new micro controller based eog guided wheel chair which is cost effective and simple with an economic and functional feasibility that would enable them to improve their quality of life. Electrooculography is a method to sense eye movement and is based on recording the steady corneal-retinal potential that is due to hyperpolarization and depolarization existing between the cornea and the retina and is commonly known as an electrooculogram (EOG).

II. MATERIALS AND METHODS

A. EOG Signal Acquisition and Electrode Placement

Electrooculographic potential (EOG) presents a good face access, good accuracy and resolution, great range of eye displacements, works in real time and is cheap. The eye act as a dipole in which the anterior pole is positive and the posterior pole is negative. In left gaze of the eye, the cornea approaches the electrode near the left eye, resulting in a positive going change and for right gaze, negative going change in the potential difference recorded from it. Three pairs of ocular muscles around the eye namely, superior rectus, inferior rectus, superior oblique, inferior oblique, medial rectus and lateral rectus are responsible for the eye ball movement to generate electric potentials to obtain EOG. EOG ranges from 0.05 to 3.5 mV in humans and is linearly proportional to eye displacement and frequency range of about 100 HZ. The human eye is an electrical dipole with a negative pole at the fundus and a positive pole at the cornea [9]-[11].

Its behavior is practically linear for gaze angles of ± 30 degrees. The corneo-retinal potential, which is aligned with optic axis and hence rotates with the direction of gaze, can be measured with the surface electrodes placed on the skin around the eyes. Many artifacts affect the EOG signal acquisition such as bio electric potentials EEG, EMG and artifacts due to positioning of electrodes, skin electrode contacts, head movements and blinking etc. To eliminate or minimize these defects, various studies were made of the accuracy and precision of the EOG in tracking the eye gaze [12]. For electrode placement, to detect vertical motion, one electrode is placed 2cm above the eye whereas another electrode is placed 1cm below the left eye. As two eyes are moving in conjunction in vertical direction, electrodes are placed for only one eye, say left eye for vertical motion. For horizontal motion detection, an electrode is placed on outer side of each eye with

Jobby K. Chacko, Deepu Oommen, Kevin K. Mathew, Noble Sunny, and N. Babu (Corresponding author) are with the Department of Biomedical engineering, V.M.K.V Engineering College, Vinayaka Mission University, Salem – 636308 (e-mail: jobbykc89@gmail.com, deepu_32@hotmail.com, kevinmathew063@gmail.com, noble.4649@gmail.com, santhurbabu@yahoo.co.in, respectively).

2cm distance from the eye. A reference electrode is placed on the subject's forehead or any other parts like limbs known as ground electrode. Fig. 1 shows the electrode positions around eyes for horizontal and vertical motion of eye. The EOG signal changes approximately $20\mu\text{V}$ for each degree of eye movement [13].



Fig. 1 The electrode positions around eyes for horizontal and vertical motion

B. Schematic Diagram of Wheelchair

Fig. 2 shows the schematic diagram of wheelchair design. At first the EOG signal is captured via the surface electrodes placed near the surrounding of the eye. The potential so developed by the movement of the eye ball generates variable voltages at different positions namely when the eyeball at rest (straight), Left, Right, Up, Down. The eye muscles are responsible for the eye movement or eye gaze thereby generating the small mill volt of bio-potential. This bio-signal is amplified and converted into digital signal. The PIC microcontroller (PIC 16F877) is the heart of the device, the signal is then fed to the input of the micro-controller. An IC program (MP lab) is done for the given input values for left, right, up, down and stationary or stop conditions. The corresponding voltage values from EOG signals results in the movement of wheel chair in the respective direction.

An object sensor is also used to detect any obstacles and results in the stop condition by the microcontroller. The output from the PIC controller is fed to the LCD display and also to the relay of the driver motor in the wheel chair.

C. PIC Microcontroller

Various microcontrollers offer different kinds of memories. EEPROM, EPROM, FLASH etc are some of the memories of which FLASH is the most recently developed. The FLASH technology is used in PIC 16F887 microcontroller, so that data is retained even when the power is switched off. Due to the features of easy erasing and programming, the PIC microcontroller was used here. Fig. 3 shows the circuit diagram for the LCD interfacing with PIC microcontroller and Fig. 4 shows the photograph of the actual wheel chair fitted with motors.

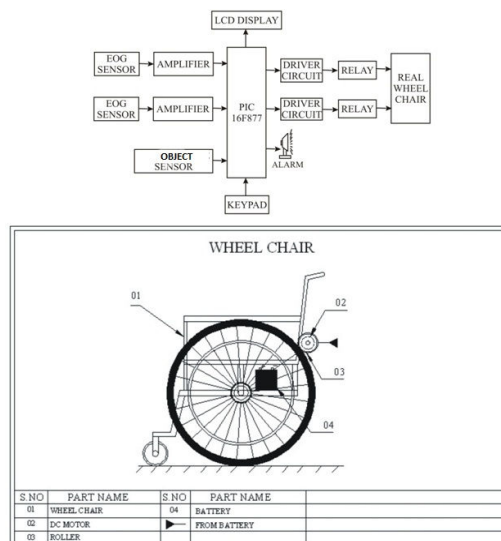

Fig. 2 The schematic diagram of wheelchair

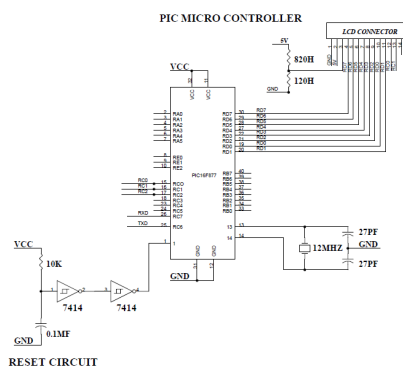

Fig. 3 Circuit diagram for the LCD interfacing with PIC microcontroller



Fig. 4 The photograph of the actual wheel chair fitted with motors

D. Relay Driver Circuit

The circuit is designed to control the load. The load here is motor to drive the wheels of the wheel chair. The motor is turned 'ON' and 'OFF' through the relay. A relay is nothing but electromagnetic switching device which consists of three pins namely common, normally close and normally open. Fig. 5 shows the circuit diagram of connecting a relay to PIC microcontroller.

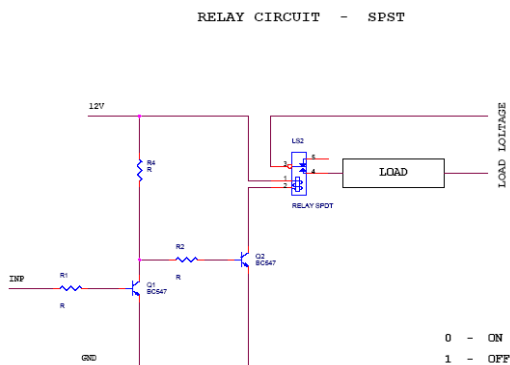

Fig. 5 The circuit diagram of connecting a relay to PIC microcontroller

E. DC Motor Circuit for Forward and Reverse

Fig. 6 shows the circuit diagram for forward and reverse direction control. It consists of two relays called relay 1 and relay 2, The ON and OFF control of this relays are controlled by a pair of switching transistors. The relays are connected in the collector terminal of Q2 and Q4 as shown in the figure. When relay 1 is in the ON state and relay 2 is in the off state, the motor is running in the forward direction and vice versa for reverse direction.

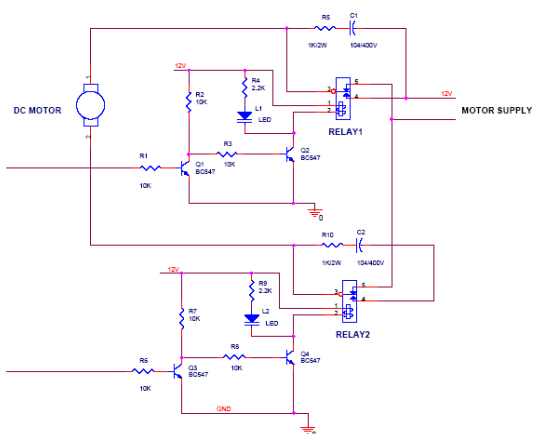

Fig. 6 The circuit diagram for dc motor for forward and reverse direction

F. IC Program

The PRO MATE II is a microchip microcontroller device programmer. Through interchangeable programming socket modules, PRO MATE II enables you to quickly and easily program the entire line of microchip PIC microcontroller devices and many of the microchip memory parts. A program written in the high level language called 'C' which will be converted into PIC micro MCU machine code by a compiler. Machine code is suitable for use by a PIC micro MCU or microchip development system product like MPLAB IDE.

III. RESULT

The wheel chair thus developed will move in the focused

direction based on the eye movement. The wheel chair is attached with two motors for the movement of wheel chair for different conditions. When the eye is focused left, one motor rotates the left wheel backward and another motor rotates the right wheel forward, so that the wheel chair moves towards left and vice versa for right movement. When the eye is focused up, both motors running forward and move the both wheels forward so that the wheel chair moves forward similarly when the eye is focused down the wheel chair moves backward as both motors move the wheel backward. While looking straight, the wheel chair will be in stop condition. The conditions can be altered in the IC program according to the user's choice. A LCD is used to display the conditions of left, right, up, down and stop. Fig. 3 shows the circuit diagram of liquid crystal display (LCD) interfacing with PIC microcontroller. An alarm system is also used in this proposed system to warn if there are any obstacles. Fig. 4 shows the photograph of the actual wheel chair used fitted with motors for forward and reverse direction.

IV. DISCUSSION

Some of the disabled community finds it difficult to use wheelchairs independently. To solve this problem for those people, researchers have used technologies originally developed for mobile wheel chairs. There are many types of wheel chairs already developed to meet the requirements of the sable people's mobility. Majority of the wheel chairs were developed based on heavily modified, commercially available power wheelchairs (e.g., NavChair [14], Office wheelchair with high Maneuverability and Navigational Intelligence [15], Mobility Aid for elderly and disabled people [16] and smaller number of smart wheelchairs [17]. These wheel chairs are not helpful for some disabled people; those cannot operate the wheel chair. Especially for these peoples, many EOG based wheel chairs with different techniques are developed [18]. An improvement in the conformability, cost and simplicity of this kind of wheel chairs can be of great utility because it provides a lot of possibilities.

Simple and cost effective micro controller based EOG signal guided wheel chair was developed for disabled people. In this work, we designed a system that allows the handicapped, especially those with only eye-motor coordination, to live more independently. Higher value of the EOG signal is obtained when eyes move upward and lower value obtained when eyes move downward, similarly for left and right movement. Whenever the signal crosses the threshold value in each direction, the microcontroller sends pre-determined values in voltages to the motors attached to the wheel chair for movement of forward and reverse direction. Even though the developed wheel chair has advantage of low cost, good reliability, simple circuitry and easy to implementation, it is not yet fully developed for commercial use. The movement of the wheel chair direction is restricted for particular direction based on horizontal and vertical movements of the eye only. But practically, eye will move not only horizontal and vertical, some oblique movements also

there. For oblique rotation of the eye, the will chair is not satisfactorily responding for movement in particular direction. Further research in design and development is needed and the progress is going on for all possible movements of the eye. The very important problems of rolling resistance, internal friction, Inertia are also to be considered to rectify or reduce to have a smooth movement of the wheel chair. But comparing the simplicity in circuitry, cost, easy to use, this design will be in very much useful for further development in eog based wheel chairs.

V.CONCLUSION

The microcontroller based wheel chair using EOG signal is successfully implemented and demonstrated. The final application of this wheel chair is it can be used in medical application for paralyzed and handicapped people. If the eye gaze is known, it is possible to develop different user interfaces to control different tasks. This technique can be applied in future for the mobility of automatic mobile bed for patients and in military services for missile projections and gun firing.

ACKNOWLEDGMENT

The authors would like to express their gratitude to Mr. Jiby Chandy, HR & project coordinator, and Mr. Selvaraj (electronic section), Medtronic solution (India) for their support in hardware and software development.

REFERENCES

- [1] Schilling, K., Roth, H., Lieb, R. and Stütze, H. "Sensors to improve the safety for wheelchair users, in: I. Placencia Porrero and E. Ballabio (eds)", Improving the Quality for the European Citizen, IOS Press, 1998.
- [2] Yanco, H. A., Hazel, A., Peacock, A., Smith, S., and Wintermute, H. "Initial report on wheelsley: A robotic wheelchair system, in: Proc. of the Workshop on Developing AI Applications for the Disabled", Internat. Joint Conf. on Artificial Intelligence, Montreal, Canada, August 1995.
- [3] Joseph A. Lahoud and Dixon Cleveland. "The Eyegaze Eyetracking System". LC Technologies, Inc. 4th Annual IEEE Dual-Use Technologies and Applications Conference.
- [4] Holly. A.Yanco, Wheelsley. "A robotic wheelchair system: Indoor navigation and user interface, Assistive Technology and Artificial Intelligence", 1998, Volume 1458/1998, 256-268,
- [5] Robert J.K. Jacob. "Eye Movement-Based Human-Computer Interaction Techniques: Toward Non- Command Interfaces". Human-Computer Interaction Lab. Naval Research Laboratory. Washington, D.C. 1995.
- [6] Barea R, Boquete L, Mazo M, López E, and Bergasa L.M, "E.o.g guidance of a wheelchair using neural networks," in Proceedings of International Conference on Pattern Recognition (ICPR'00), Spain, September 2000, pp. 668-671.
- [7] Naoaki Itakura, K. Sakamoto. "A new method for calculating eye movement displacement from AC coupled electro-oculographic signals in head mounted eye-gaze input interfaces, Biomedical signal processing and control" 2010, 5(2), 142-146.
- [8] Yutaka satoh, and Katsuhiko sakaue, "An Omnidirectional Stereo Vision Based Smart Wheelchair", EURASIP Journal on Image and Video Processing 2007, Article ID 87646, 1-11.
- [9] Barea R, Boquete L, Mazo M, López E. "Guidance of a wheelchair using electrooculography". Proceedings of the 3rd IMACS International Multiconference on Circuits, Systems, Communications and Computers (CSCC'99). July 1999. Greece.
- [10] Barea R, Boquete L, Mazo M, López E, L.M. "Bergasa. "Help to the mobility and the communication by means of ocular movements". Proceeding of TELECOM 2000. Santiago de cuba. Cuba. July 2000.
- [11] Barea R, Boquete L, Mazo M, López E, "EOG technique to guide a wheelchair". Proceeding of 16th IMACS World Congress.Laussana, Switzerland. August 2000.
- [12] North, A. W. "Accuracy and precision of electrooculographic recording", Invest. Ophthalmol. (1965), 4, 343-348.
- [13] Barea R, Boquete L, Mazo M and López E, "Wheelchair Guidance Strategies Using EOG", Journal of Intelligent and Robotic Systems, 2002, 34, 279-299.
- [14] Levine SP, Bell DA, Jaros LA, Simpson RC, Koren Y, Borenstein J. "The NavChair assistive wheelchair navigation system", IEEE Trans Rehabil Eng. 1999, 7(4), 443-51.
- [15] Borgolte U, Hoyer H, Buehler C, Heck H, Hoelper R. "Architectural concepts of a semi-autonomous wheelchair", J Intell Robotic Syst. 1998; 22(3/4),233-53.
- [16] Prassler E, Scholz J, Fiorini P. "A robotic wheelchair for crowded public environments", IEEE Robot Autom Mag. 2001,8(1),38-45.
- [17] Simpson RC, LoPresti EF, Hayashi S, Nourbakhsh IR, Miller DP. "The smart wheelchair component system". J Rehabil Res Dev. 2004, 41(3B), 429-42.
- [18] Richard C. Simpson, "Smart wheelchairs: A literature review", Journal of Rehabilitation Research & Development, 2005, 42(4), 423-436.