

Measurements of Radial Velocity in Fixed Fluidized Bed for Fischer-Tropsch Synthesis Using LDV

Xiaolai Zhang, Haitao Zhang, Qiwen Sun, Weixin Qian, Weiyong Ying

Abstract—High temperature Fischer-Tropsch synthesis process use fixed fluidized bed as a reactor. In order to understand the flow behavior in the fluidized bed better, the research of how the radial velocity affects the entire flow field is necessary. Laser Doppler Velocimetry (LDV) was used to study the radial velocity distribution along the diameter direction of the cross-section of the particle in a fixed fluidized bed. The velocity in the cross-section is fluctuating within a small range. The direction of the speed is a random phenomenon. In addition to r/R is 1, the axial velocity are more than 6 times of the radial velocity, the radial velocity has little impact on the axial velocity in a fixed fluidized bed.

Keywords—LDV, fixed fluidized bed, velocity, Fischer-Tropsch synthesis.

I. INTRODUCTION

IN 1925, German scientists F. Fischer and H. Tropsch discovered that if carbon monoxide and hydrogen are over an iron catalyst, under 15MPa, 400°C, which can convert into liquid hydrocarbons, known as the Fischer-Tropsch synthesis [1], [2]. Depending on the target product, different catalysts and reaction conditions, Fischer-Tropsch synthesis can be divided into low temperature F-T synthesis and high temperature F-T synthesis process [3], [4]. Circulating fluidized bed reactor and fixed fluidized bed reactor are mainly used in the High temperature Fischer-Tropsch synthesis process [5].

In the early research, for a circulating fluidized bed reactor, carbon deposition reduces the catalyst density and the amount of the catalyst, causing fractional conversion down [6], [7]. Therefore, the circulating fluidized bed reactor needs to remove the coked catalyst and add fresh catalyst into the reactor in order to maintain the stability of the fractional conversion and production capacity [8]. While using a fixed fluidized bed reactor, the coked catalyst decreases the density of the catalyst, higher the bed height can maintain the stability of the fractional conversion and production capacity. In addition, the fixed

fluidized bed reactor also has the advantages of small volume, simple equipment, low cost, easy operation and other characteristics [6], [9].

In the particle velocity measurement system, Laser Doppler velocimetry system (LDV) attracted many people's attention by its performance. LDV uses the Doppler principle to measure the particle local velocity, there is a certain frequency difference between the incident and scattered light on the motional particles, which is known as the Doppler shift [10], [11]. LDV is the technique of using the Doppler shift in a laser beam to measure the velocity of the particles. Laser Doppler velocimetry is often chosen over other forms of flow measurement because the equipment has no effect on the flow [12]-[14].

In this experiment fixed fluidized bed is selected as the reactor for the High temperature F-T synthesis. For a fluidized bed reactor, when it comes to industrial scale, knowing the distribution of the flow field of particles is a good way to know the catalyst residence time in the fluidized bed. The main speed of the particle in the flow field is along the upward air flow [15]-[17]. However, with the particle rises, it is necessary to know that how the radial velocity affect the entire flow field. By using Laser Doppler velocimetry system, this paper gives the radial velocity distribution along the diameter direction of the particle in a fixed fluidized bed, in order to understand the flow behavior better.

II. EXPERIMENT

The main experimental device in this essay is a fixed fluidized bed reactor and a Laser Doppler Velocimetry system (LDV).

The fixed fluidized bed reactor is made by plexiglass, the diameter of which is 0.3m; the overall height is 6m. The gas in this experiment is provided by the gas compressor. After passing a buffer tank, then go through into the filter and a freeze drier in order to remove the oil, the gas of the water and the other impurities. The gas flow is regulated by the flow control valve, recording the gas flow data by the rotameter, then goes into the fluidized bed. The discharge valve is settled at the bottom of the fluidized bed. The Feed inlet settled at the 1.8m high from the bottom. Fig. 1 shows the cold model experimental process of gas-solid fluidized bed for Fischer-Tropsch synthesis.

The LDV system (TSI Inc.) mainly consists of an argon ion laser (Coherent, LA70-5E), which provide three color laser (514.5nm, 488nm, 476.5nm). For a three-dimensional velocity component measurements often use double probe arrangement in which have a two-dimensional measurement probe (TR-260)

X.L. Zhang is with Engineering Research Center of Large Scale Reactor Engineering and Technology, Ministry of Education, State Key Laboratory of Chemical Engineering, East China University of Science and Technology, Shanghai, 200237, PR China (e-mail: zhangxlai@sina.com).

H. T. Zhang and W. X. Qian are with Engineering Research Center of Large Scale Reactor Engineering and Technology, Ministry of Education, State Key Laboratory of Chemical Engineering, East China University of Science and Technology, Shanghai, 200237, PR China.

Q. W. Sun is with State Key Laboratory of Coal Liquefaction and Coal Chemical Technology, Shanghai, 201203, PR China.

W. Y. Ying is with Engineering Research Center of Large Scale Reactor Engineering and Technology, Ministry of Education, State Key Laboratory of Chemical Engineering, East China University of Science and Technology, Shanghai, 200237, PR China (Corresponding author to provide phone: +86 21 64252192; fax: +86 21 64252192; e-mail: wyying@ecust.edu.cn).

and a one-dimensional measurement probe (TR-160). The data got from the LDV system is processed in the computer by the software FlowSizer64 (TSI Inc.).

The particle used in the fluidized bed is glass beads; the diameter of the particle is in the range of 0.15-0.18mm.

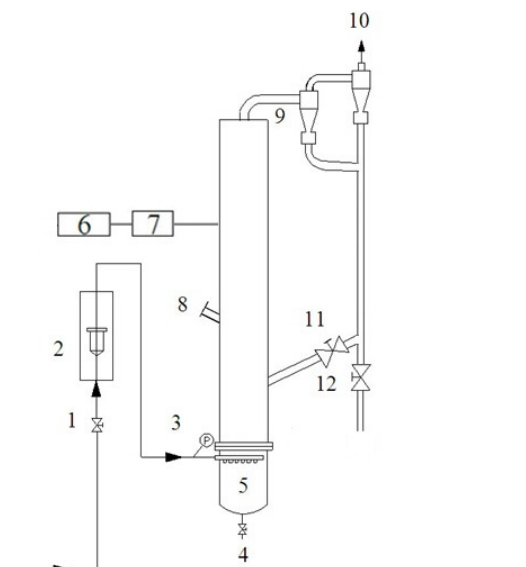

Fig. 1 Cold model experimental process of gas-solid fluidized bed for Fischer-Tropsch synthesis 1-Flow control valve, 2-Rotameter, 3-Pressure gauge, 4-Discharge valve, 5-Gas distributor, 6-LDV system, 7-Computer, 8-Feed inlet, 9-cyclone, 10-exhaust port, 11-particle circulation control valve, 12-particle circulation discharge valve

After starting the experiment, keep the fixed fluidized bed reactor fluidized state for more than 15 minutes, the fixed fluidized bed reactor is considered to be at a steady state, adjust the LDV to the corresponding experimental conditions, and then start measurement.

The static bed height in the experiment is 0.3m, 0.5m, 0.7m, 0.9m, 1.1m, and the test point in the experiment is 2.05m-2.65m high, the results have similarities, so the analysis use the static bed height is 0.7m, the test point is 2.35m high.

III. RESULTS AND ANALYSIS

For a fluidized bed reactor, the main speed of the particle in the fluidized bed is along the upward air flow. However, with the particle rises, its radial velocity changes also affect the entire flow field. Since the fluidized bed is cylindrical, the measurement point along the diameter direction of the cross-section is selected in order to reduce the refraction of the fluidized bed.

By using LDV, the average speed at the measurement point over a period of time is taken. Since the number of the measurement points is not the same at every second, Table I shows the distribution of the particle velocity in 20 seconds. The distribution of the particle velocity is substantially into a normal distribution, which can prove that the data obtained is good. Data is mainly concentrated in the range of 0m/s, hardly

obtained in the large velocity region. The absolute value of each point is very small.

TABLE I
THE AMOUNT OF THE PARTICLE VELOCITY IN 20 SECONDS

Range of velocity	Amount
-0.7~-0.6	1
-0.6~-0.5	3
-0.5~-0.4	14
-0.4~-0.3	27
-0.3~-0.2	99
-0.2~-0.1	232
-0.1~0	449
0~0.1	424
0.1~0.2	283
0.2~0.3	129
0.3~0.4	27
0.4~0.5	11
0.5~0.6	7

In order to describe the average particle velocity better, the average data in each second is given within 20 seconds. The static bed height is 0.7m, the test point is 2.35m high, the gas velocity is 0.5504m/s, r/R is 0.6 in Fig. 2. Each point is the average particle velocity at that second. It can be seen from the figure, each data increase or decline is randomly distributed. The absolute value is within 0.15m/s, in the experimental time, there is a fluctuation in the vicinity of a certain value. After the entire data processing, the average velocity at this point is 0.00849m/s.

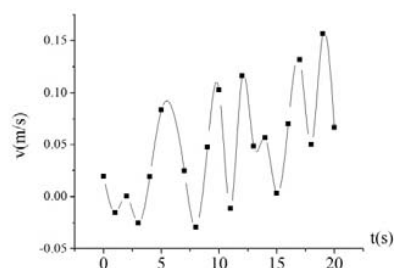

Fig. 2 The average particle velocity in each second within 20 seconds

Fig. 3 is given in order to illustrate the case of particle motion under different gas velocity. The static bed height is 0.7m; the test point is 2.35m high in Fig. 3. The data of the velocity is randomly positive or negative, the direction of the speed is not determined, to one side or the other side is a random phenomenon, but the numerical value is fluctuating within a small range. With the increasing of the gas flow, there is no change for the randomness of the particle direction. The directivity of the particle velocity is not changed with the velocity of the gas.

Fig. 4 is the absolute value of Fig. 3. It can be seen in the picture that without considering the direction of the particle, the radial velocity under different gas velocity does not show obvious change, which means with the increase of the gas velocity the particle fluctuate in a stable range. The absolute values is less than 0.01m/s, which means the velocity is very

small, it cannot obviously change the fluidization state in a fluidized bed. In different radial position, the velocity is different, but it is less than a certain numerical value, which means has little effect on the axial movement of the fluidized bed.

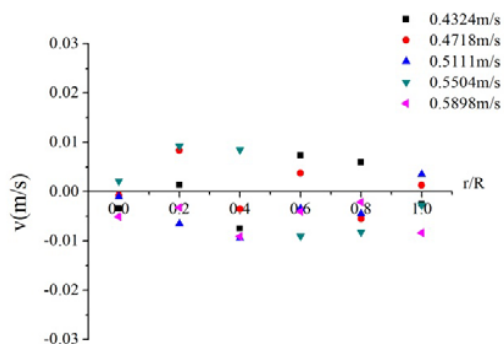

Fig. 3 Particle velocity under different gas velocity

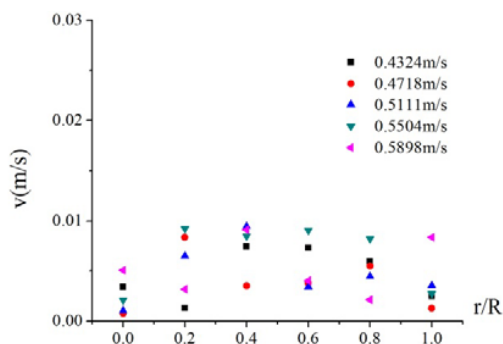

Fig. 4 The absolute value of the velocity under different gas velocity

TABLE II
THE RATIO OF THE AXIAL VELOCITY AND RADIAL VELOCITY

v(m/s)	r/R					
	0	0.2	0.4	0.6	0.8	1
0.4324m/s	20.57	54.84	7.69	6.61	7.45	3.83
0.4718m/s	110.30	9.5	18.6	14.85	8.44	5.27
0.5111m/s	98.18	14.45	8.7	21.53	12.3	3.48
0.5504m/s	51.32	10.2	11.78	9.77	8.35	3.93
0.5898m/s	22.53	30.54	12.1	25.77	34.65	0.72

In order to visually show, the difference between axial velocity and radial velocity, Table I gives the ratio of the axial velocity and radial velocity. The static bed height is 0.7m; the test point is 2.35m high in the Table II. As can be seen from the table, at the column r/R is 1, because of the wall effects, the axial velocity itself is very small, which led to the ratio is not the same as other data [17]. In addition to column r/R is 1; all the test points in the axial velocity are more than 6 times of the radial velocity. When r/R is 0, the test point is in the center of the cross section, the axial velocity is more than 20 times of the radial velocity, which means in the center of the cross section, the radial speed can be negligible. When the gas velocity is 0.4324m/s, the ratio of some point is less than 8, while the gas velocity is 0.5898m/s, the ratio of all the point is the more than

12, in addition to r/R is 1. Because the ratio of the axial velocity and radial velocity is relatively large, it can be considered that the radial velocity is not a great impact on the flow state.

IV. CONCLUSION

The experiment use the glass beads as the fluidizing medium, the diameter of which is in the range of 0.15-0.18mm, the effective height of the fluidized bed is 6m, and the inner diameter is 0.3m. Using LDV to measure the distribution of radial velocity along the diameter direction in the fluidized bed some conclusions are summarized as follows:

The velocity is very small. The absolute values of the velocity along the diameter direction in the cross-section is less than 0.01m/s, which means it has little effect on the axial velocity along the diameter direction in the cross-section. It cannot obviously change the fluidization state in a fluidized bed.

The velocity along the diameter direction in the cross-section is fluctuating within a small range. The direction of the speed is not determined, to one side or the other side is a random phenomenon. On the whole the absolute value of the velocity is in the range of 0.01m/s.

In addition to r/R is 1, the axial velocity are more than 6 times of the radial velocity. When r/R is 1, because of the wall effects, the axial velocity itself is very small, which led to the ratio is not the same as other data. As the experimental results and discussion above, it can be considered that, the radial velocity has little impact on the axial velocity in a fixed fluidized bed.

ACKNOWLEDGMENT

The authors gratefully acknowledge the financial support of the National High-Tech R&D Program of China (2011AA05A204) and Shanghai Yankuang Energy R&D Co. Ltd.

REFERENCES

- [1] Atwood H E, Bennett C. O., "Kinetics of the Fischer-Tropsch reaction over iron," in 1979 Ind Eng Chem Proc Des Dev, vol.18, pp. 163-170 .
- [2] Wang Y N, Xu Y Y, and Li Y W, "Heterogeneous modeling for fixed-bed Fischer-Tropsch synthesis: reactor model and its applications," in 2003 vol.58, Chem Eng Sci, pp. 867-875.
- [3] G Ttel R., Turek T., "Comparison of different reactor types for low temperature Fischer-Tropsch synthesis: a simulation study," in 2009 vol.64, Chem Eng Sci, pp. 955-964.
- [4] Marvast M. A., Sohrabi M., and Zarrinpashne S., "Fischer-Tropsch synthesis: modeling and performance study for Fe-HZSM5 bifunctional catalyst," in 2005 vol.28 ChemEng Technol., pp. 78-86.
- [5] Wu J, Zhang H, and Ying W, "Simulation and analysis of a tubular fixed-bed Fischer-Tropsch synthesis reactor with Co-based catalyst," in 2010 vol.33, ChemEngTechnol, pp. 1083-1092.
- [6] K. Tomishige, "Syngas production from methane reforming with CO₂/H₂O and O₂ over NiO-MgO solid solution catalyst in fluidized bed reactors," in 2004 vol.89, Catal Today, pp. 405-418.
- [7] Y. S. Teplitskiy, "Similarity of transport processes in fluidized beds," in 1999 vol.42, Int. J. Heat Mass Transfer, pp. 3887-3899.
- [8] C. B. Solnordal, K.J. Reid, "Modeling coke distribution above the freeboard of a fluid coking reactor," in 2012 vol.51, Ind. Eng. Chem. Res., pp. 15337-15350.
- [9] E. Guazzelli, J.Hinch, "Fluctuations and instability in sedimentation," in 2011 vol.43, Annu. Rev. Fluid Mech, pp. 97-116.

- [10] L. Pietri, M. Amielh, and F. Anselmet, "Simultaneous measurements of temperature and velocity fluctuations in a slightly heated jet combining a cold wire and Laser Doppler Anemometry," in 2000 vol.21, International Journal of Heat and Fluid Flow, pp. 22-36.
- [11] N. Pedersen, P. S Larsen, and C. B Jacobsen, "Flow in a Centrifugal Pump Impeller at Design and Off-Design Conditions—Part I: Particle Image Velocimetry (PIV) and Laser Doppler Velocimetry (LDV) Measurements," in 2003, ASME J. Fluids Eng., pp. 61-72.
- [12] J. Werther, B. Hage, and C. Rudnick, "A comparison of laser Doppler and single-fiber reflection probes for the measurement of the velocity of solids in a gas–solid circulating fluidized bed," in 1996 vol.35 Chemical Engineering and Processing., pp. 381-391.
- [13] A. G. Mychkovsky, N. A. Chang, S. L. Ceccio, "Bragg cell laser intensity modulation: effect on laser Doppler velocimetry measurements," in 2009 vol.48, Applied Optics, pp. 3468-3474.
- [14] J. Adanez, J. C. Abanades, "Minimum fluidization velocities of fluidized-bed coal-combustion solids," in 1991 vol.67, Powder Technology., pp. 113-119 .
- [15] K. Obha, Y. Tsutomu, H. Matsuyama, "Simultaneous measurements of bubble and liquid velocities in two-phase flow using LDV," in 1991 vol.29, Bulletin of JSME., pp. 2487-2493.
- [16] C. Chatzidoukas, J. D. Perkins, E. N. Pistikopoulos, and C. Kiparissides, "Optimal grade transition and selection of closed-loop controllers in a gas-phase olefin polymerization fluidized bed reactor," in 2003 vol.58, Chemical Engineering Science., pp. 3643-3658.
- [17] R. W. Breault, C. P. Guenther, and L. J. Shadle, "Velocity fluctuation interpretation in the near wall region of a dense riser," in 2008, Powder Technology, pp. 137-145.