

LQG Flight Control of VTAV for Enhanced Situational Awareness

Igor Astrov, Mikhail Pikkov, Rein Paluoja

Abstract—This paper focuses on a critical component of the situational awareness (SA), the control of autonomous vertical flight for vectored thrust aerial vehicle (VTAV). With the SA strategy, we proposed a linear-quadratic-Gaussian (LQG) flight control procedure for an unmanned helicopter model with vectored thrust configuration. This LQG control for chosen model of VTAV has been verified by simulation of take-off and landing maneuvers using software package Simulink and demonstrated good performance for fast flight stabilization of model, consequently, fast SA with economy in energy can be asserted during search-and-rescue operations.

Keywords—Linear-Quadratic-Gaussian (LQG) controller, situational awareness, vectored thrust aerial vehicle.

I. INTRODUCTION

SITUATION awareness has been formally defined as "the perception of elements in the environment within a volume of time and space, the comprehension of their meaning, and the projection of their status in the near future" [1]. As the term implies, situation awareness refers to awareness of the situation. Grammatically, situational awareness (SA) refers to awareness that only happens sometimes in certain situations.

SA has been recognized as a critical, yet often elusive, foundation for successful decision-making across a broad range of complex and dynamic systems, including emergency response and military command and control operations [2].

The term SA have become commonplace for the doctrine and tactics, and techniques in the U.S. Army [3]. SA is defined as "the ability to maintain a constant, clear mental picture of relevant information and the tactical situation including friendly and threat situations as well as terrain". SA allows leaders to avoid surprise, make rapid decisions, and choose when and where to conduct engagements, and achieve decisive outcomes.

In [4], a novel design of a multi-rotor wing platform which has great potential for both military and civilian application areas is presented. These platforms can provide the greater SA in the urban terrain.

The vectored thrust aerial vehicle (VTAV) is one of the key tools to gather the information to build SA for all leaders. The

VTAV is the ground maneuver commander's primary day and night system. The VTAV provides the commander with a number of capabilities including:

- Enhanced SA.
- Target acquisition.
- Battle damage assessment.
- Enhanced battle management capabilities (friendly situation and battlefield visualization).

The combination of these benefits contributes to the commander's dominant SA allowing him to shape the battlefield to ensure mission success and to maneuver to points of positional advantage with speed and precision to conduct decisive operations. Some conditions for conducting aerial reconnaissance with VTAVs are as follows.

- Time is limited or information is required quickly.
- Detailed reconnaissance is not required.
- Extended duration surveillance is not required.
- Target is at extended range.
- Threat conditions are known; also the risk to ground assets is high.
- Verification of a target is needed.
- Terrain restricts approach by ground units.

The VTAV offers many advantages, including low cost, the ability to fly within a narrow space where the objects in the proximity of the vehicle are protected from the propeller and vice versa, and the unique hovering and vertical take-off and landing (VTOL) flying characteristics.

Autonomous vertical flight is a challenging but important task for VTAVs to achieve high level of autonomy under adverse conditions. The fundamental requirement for vertical flight is the knowledge of the height above the ground, and a properly designed controller to govern the process.

In [5], a three stage flight control procedure using three autonomous control subsystems for a nontrivial nonlinear helicopter model on the basis of equations of vertical motion for the center of mass of helicopter was proposed. The proposed control strategy has been verified by simulation of hovering maneuvers using software package Simulink and demonstrated good performance for fast SA.

This paper concentrates on issues related to the area of [5], but demonstrates another field for application of these ideas, i.e., research technique using control system modeling and simulation on the basis of state-space equations of motion of VTAV.

In this paper our research results in the study of vertical flight (take-off and landing cases) control of VTAV which make such SA task scenario as "go-search-find-return" possible are presented.

I. Astrov is with the Department of Computer Control, Tallinn University of Technology, Tallinn 19086, Estonia (phone: 372-620-2113, fax: 372-620-2101; e-mail: igor.astrov@dcc.ttu.ee).

M. Pikkov is with the Thomas Johann Seebeck Department of Electronics, Tallinn University of Technology, Tallinn 19086, Estonia (e-mail: mpikk@elin.ttu.ee).

R. Paluoja is with the Department of Computer Control, Tallinn University of Technology, Tallinn 19086, Estonia (e-mail: rein.paluoja@dcc.ttu.ee).

The contribution of the paper is twofold: to develop new schemes appropriate for SA enhancement using VTAVs by control of vertical flight, and to present the results of flight maneuvers for chosen model of VTAV for fast SA in simulation form using the MATLAB/Simulink environment.

II. VTAV MODEL

In [6], a model of VTAV was proposed. The VTAV which has a triangular shape consists of three ducted fans. The axis of the front ducted fan is fixed perpendicular to the plane of the triangle, whilst the rear two fans are able to rotate around an axis which is common to both fans. The independent vectoring of these two fans allows the yaw motion and forward flight with minimal or no pitch movement. This VTAV has a weight 5.5kg and a distance 0.231m from the center of gravity to all the fans.

The dynamic model of this VTAV demonstrates unstable equilibrium and is significantly simpler than the dynamic model of a helicopter. The fact that the system is in unstable equilibrium also allows us to develop control systems that will provide greater maneuverability than would have been possible with quad-rotor systems or co-axial helicopters. Unlike single ducted fan systems, this design provides ample space for a sizable payload bay. Minimal pitch and roll movements ensure that the VTAV is suitable to carry vision sensors and laser range sensors for terrain mapping where the attitude of the sensors play a major role on the reliability of acquired data.

The dynamic model for control yields the general form of state equations for the VTAV [6]

$$\dot{x}(\tau) = Ax(\tau) + Bu(\tau) + v(\tau) \quad (1)$$

$$y(\tau) = Cx(\tau) + w(\tau) \quad (2)$$

where $x(\tau)$, $u(\tau)$, $y(\tau)$, $v(\tau)$, $w(\tau)$ are the state, control input, output, process noise and measurement noise vectors, respectively.

The variables of this model are:

$$\begin{aligned} x^T &= (\dot{x}_c, \dot{y}_c, \dot{z}_c, \phi, \theta, \psi, \omega_x, \omega_y, \omega_z), \\ u^T &= (\omega_{f_1}, \omega_{f_2}, \omega_{f_3}, \theta_{t_2}, \theta_{t_3}) \end{aligned} \quad (3)$$

where x_c, y_c, z_c are coordinates of center of mass of VTAV in the earth-frame, ϕ, θ, ψ are roll, pitch and yaw angles; $\omega_x, \omega_y, \omega_z$ are roll, pitch and yaw rates; $\omega_{f_1}, \omega_{f_2}, \omega_{f_3}$ are angular speeds of the first, second, and third motors; $\theta_{t_2}, \theta_{t_3}$ are vectoring angles of second and third fans.

The matrix structure of A, B, C for the state-space model of system (1)-(2) is given by

$$\begin{aligned} A &= \begin{bmatrix} a_{11} & 0 & 0 & 0 & a_{15} & 0 & 0 & 0 & 0 \\ 0 & a_{22} & 0 & a_{24} & 0 & 0 & 0 & 0 & 0 \\ 0 & 0 & 0 & 0 & 0 & 0 & 0 & 0 & 0 \\ 0 & 0 & 0 & 0 & 0 & 0 & 1 & 0 & 0 \\ 0 & 0 & 0 & 0 & 0 & 0 & 0 & 1 & 0 \\ 0 & 0 & 0 & 0 & 0 & 0 & 0 & 0 & 1 \\ 0 & a_{72} & 0 & 0 & 0 & 0 & 0 & 0 & 0 \\ a_{81} & 0 & 0 & 0 & 0 & 0 & 0 & 0 & 0 \\ 0 & 0 & 0 & 0 & 0 & 0 & 0 & 0 & 0 \end{bmatrix}, \\ B &= \begin{bmatrix} 0 & 0 & 0 & b_{14} & b_{15} \\ 0 & 0 & 0 & 0 & 0 \\ b_{31} & b_{32} & b_{33} & 0 & 0 \\ 0 & 0 & 0 & 0 & 0 \\ 0 & 0 & 0 & 0 & 0 \\ 0 & 0 & 0 & 0 & 0 \\ 0 & b_{72} & b_{73} & 0 & 0 \\ b_{81} & b_{82} & b_{83} & 0 & 0 \\ 0 & 0 & 0 & b_{94} & b_{95} \end{bmatrix}, C = I_9 \end{aligned} \quad (4)$$

The parameters a_{11} through a_{81} and parameters b_{14} through b_{95} in (4) are given by:

$$\begin{aligned} a_{11} &= -0.0052, a_{15} = -9.8100, a_{22} = -0.0052, \\ a_{24} &= 9.8100, a_{72} = -0.0311, a_{81} = 0.0056; \\ b_{14} &= -3.2700, b_{15} = -3.2700, b_{31} = -0.3448, \\ b_{32} &= -0.3448, b_{33} = -0.3448, b_{72} = -16.5640, \\ b_{73} &= 16.5640, b_{81} = 3.4254, b_{82} = -1.7127, \\ b_{83} &= -1.7127, b_{94} = 39.2257, b_{95} = -39.2257. \end{aligned}$$

Then, we have

$$x(\tau) = \int_0^\tau \dot{x}(t)dt, y(\tau) = \int_0^\tau \dot{y}(t)dt, z(\tau) = \int_0^\tau \dot{z}(t)dt, \quad (5)$$

where

$$x_c(0) = 0, y_c(0) = 0, z_c(0) = 0.$$

From (1)-(5) we can see that the attitude vector $(x_c, y_c, z_c)^T$ for given model of VTAV can be computed.

III. SIMULATION RESULTS

Consider the control of given VTAV model (1)-(2) for the case of take-off and landing maneuvers.

The goal of the following simulations is twofold. First, we verify that this control system is able to control the flight trajectory of given VTAV. Second, we observed the effect of enhancing SA because of changing of all three desired coordinates can be changed the possible flight trajectory of given VTAV.

Initial position and desired heights for control system are chosen to be:

$$x(0) = 0m, y(0) = 0m, z(0) = 0m, z_1^0 = 12m, z_2^0 = 0m \quad (6)$$

The optimal gain matrix K for linear-quadratic regulator with output weighting and the observer gain matrix L for the stationary Kalman filter for the linear-quadratic-Gaussian (LQG) control of the original system are defined as

$$K = \begin{bmatrix} k_{11} & k_{12} & k_{13} & k_{14} & k_{15} & k_{16} & k_{17} & k_{18} & k_{19} \\ k_{21} & k_{22} & k_{23} & k_{24} & k_{25} & k_{26} & k_{27} & k_{28} & k_{29} \\ k_{31} & k_{32} & k_{33} & k_{34} & k_{35} & k_{36} & k_{37} & k_{38} & k_{39} \\ k_{41} & k_{42} & k_{43} & k_{44} & k_{45} & k_{46} & k_{47} & k_{48} & k_{49} \\ k_{51} & k_{52} & k_{53} & k_{54} & k_{55} & k_{56} & k_{57} & k_{58} & k_{59} \end{bmatrix}, \quad (7)$$

$$L = \begin{bmatrix} l_{11} & l_{12} & l_{13} & l_{14} & l_{15} & l_{16} & l_{17} & l_{18} & l_{19} \\ l_{21} & l_{22} & l_{23} & l_{24} & l_{25} & l_{26} & l_{27} & l_{28} & l_{29} \\ l_{31} & l_{32} & l_{33} & l_{34} & l_{35} & l_{36} & l_{37} & l_{38} & l_{39} \\ l_{41} & l_{42} & l_{43} & l_{44} & l_{45} & l_{46} & l_{47} & l_{48} & l_{49} \\ l_{51} & l_{52} & l_{53} & l_{54} & l_{55} & l_{56} & l_{57} & l_{58} & l_{59} \\ l_{61} & l_{62} & l_{63} & l_{64} & l_{65} & l_{66} & l_{67} & l_{68} & l_{69} \\ l_{71} & l_{72} & l_{73} & l_{74} & l_{75} & l_{76} & l_{77} & l_{78} & l_{79} \\ l_{81} & l_{82} & l_{83} & l_{84} & l_{85} & l_{86} & l_{87} & l_{88} & l_{89} \\ l_{91} & l_{92} & l_{93} & l_{94} & l_{95} & l_{96} & l_{97} & l_{98} & l_{99} \end{bmatrix}$$

The parameters k_{11} through k_{59} and parameters l_{11} through l_{99} in (7) are given by:

$$\begin{aligned} k_{11} &= -0.1168, k_{12} = 0.0030, k_{13} = -0.5777, k_{14} = 0.0016, \\ k_{15} &= 1.8887, k_{16} = -1.9200e-005, k_{17} = 0.0001, \\ k_{18} &= 1.1754, k_{19} = 6.7339e-006, k_{21} = 0.0624, \\ k_{22} &= -0.7021, k_{23} = -0.5802, k_{24} = -3.4915, \\ k_{25} &= -0.9428, k_{26} = 2.8958e-005, k_{27} = -0.8430, \\ k_{28} &= -0.5886, k_{29} = 2.1662e-005, k_{31} = 0.0632, \\ k_{32} &= 0.7065, k_{33} = -0.5741, k_{34} = 3.4846, k_{35} = -0.9448, \\ k_{36} &= -9.7412e-006, k_{37} = 0.8430, k_{38} = -0.5877, \end{aligned}$$

$$\begin{aligned} k_{39} &= -2.8398e-005, k_{41} = -0.6985, k_{42} = 0.0004, \\ k_{43} &= -0.0036, k_{44} = 0.0024, k_{45} = 1.2537, k_{46} = 0.7071, \\ k_{47} &= -0.0001, k_{48} = 0.1207, k_{49} = 0.7197, k_{51} = -0.6985, \\ k_{52} &= 0.0003, k_{53} = -0.0036, k_{54} = 0.0024, k_{55} = 1.2536, \\ k_{56} &= -0.7071, k_{57} = -2.2578e-005, k_{58} = 0.1206, \\ k_{59} &= -0.7197; \\ l_{11} &= 1.0696, l_{12} = -2.9691e-017, l_{13} = -3.3417e-018, \\ l_{14} &= -2.1237e-018, l_{15} = -0.0590, l_{16} = -2.4863e-017, \\ l_{17} &= -2.8997e-018, l_{18} = -0.0095, l_{19} = 2.9888e-018, \\ l_{21} &= -2.9691e-017, l_{22} = 1.3749, l_{23} = -2.0515e-019, \\ l_{24} &= 0.0976, l_{25} = 6.7919e-018, l_{26} = -1.7916e-016, \\ l_{27} &= 0.0026, l_{28} = 8.4541e-019, l_{29} = -4.3357e-018, \\ l_{31} &= -3.3417e-018, l_{32} = -2.0515e-019, l_{33} = 0.0141, \\ l_{34} &= -2.0660e-019, l_{35} = 4.8439e-019, \\ l_{36} &= -3.5292e-017, l_{37} = 8.0678e-019, \\ l_{38} &= 2.3998e-019, l_{39} = 8.3480e-019, \\ l_{41} &= -2.1237e-018, l_{42} = 0.0976, l_{43} = -2.0660e-019, \\ l_{44} &= 0.0136, l_{45} = 2.3099e-019, l_{46} = -1.8419e-017, \\ l_{47} &= 0.0048, l_{48} = 3.7421e-019, l_{49} = -4.6925e-019, \\ l_{51} &= -0.0590, l_{52} = 6.7919e-018, l_{53} = 4.8439e-019, \\ l_{54} &= 2.3099e-019, l_{55} = 0.0055, l_{56} = 8.3076e-019, \\ l_{57} &= 1.4094e-019, l_{58} = 0.0017, l_{59} = -3.0055e-019, \\ l_{61} &= -2.4863e-017, l_{62} = -1.7916e-016, \\ l_{63} &= -3.5292e-017, l_{64} = -1.8419e-017, \\ l_{65} &= 8.3076e-019, l_{66} = 0.1670, l_{67} = -7.3422e-018, \\ l_{68} &= 5.9865e-019, l_{69} = 0.0139, l_{71} = -2.8997e-018, \\ l_{72} &= 0.0026, l_{73} = 8.0678e-019, l_{74} = 0.0048, \\ l_{75} &= 1.4094e-019, l_{76} = -7.3422e-018, l_{77} = 0.0034, \\ l_{78} &= 2.1112e-019, l_{79} = -3.2055e-019, l_{81} = -0.0095, \\ l_{82} &= 8.4541e-019, l_{83} = 2.3998e-019, \\ l_{84} &= 3.7421e-019, l_{85} = 0.0017, l_{86} = 5.9865e-019, \\ l_{87} &= 2.1112e-019, l_{88} = 0.0009, l_{89} = -6.9329e-020, \\ l_{91} &= 2.9888e-018, l_{92} = -4.3357e-018, \\ l_{93} &= 8.3480e-019, l_{94} = -4.6925e-019, \\ l_{95} &= -3.0055e-019, l_{96} = 0.0139, l_{97} = -3.2055e-019, \\ l_{98} &= -6.9329e-020, l_{99} = 0.0024. \end{aligned}$$

Simulation results of the offered block scheme (see Fig. 1) are shown in Figs. 2-6.

Some advantages of this example are as follows;

- Possibility to consider a terrain restriction in a place of destination.
- Possibility of hovering in one selected height position.
- Using of one control system to control the take-off and landing trajectories of flight.

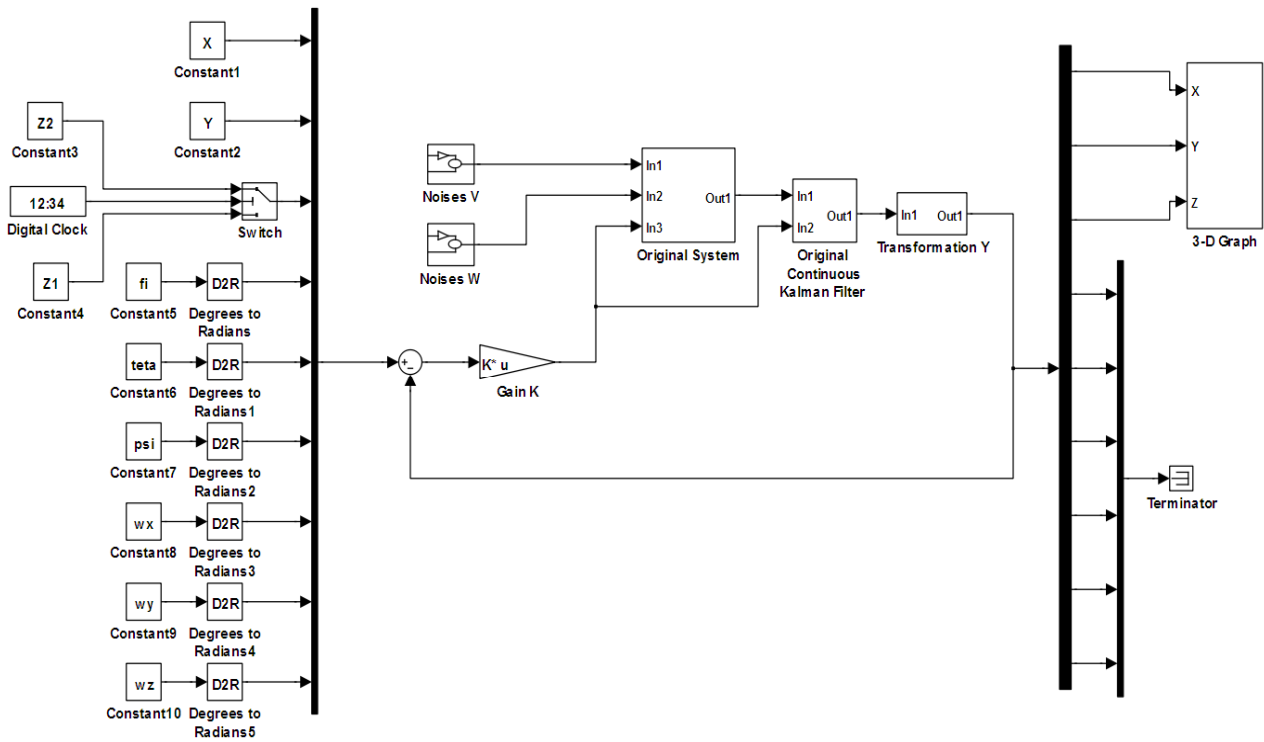

Fig. 1 Block diagram of control system.

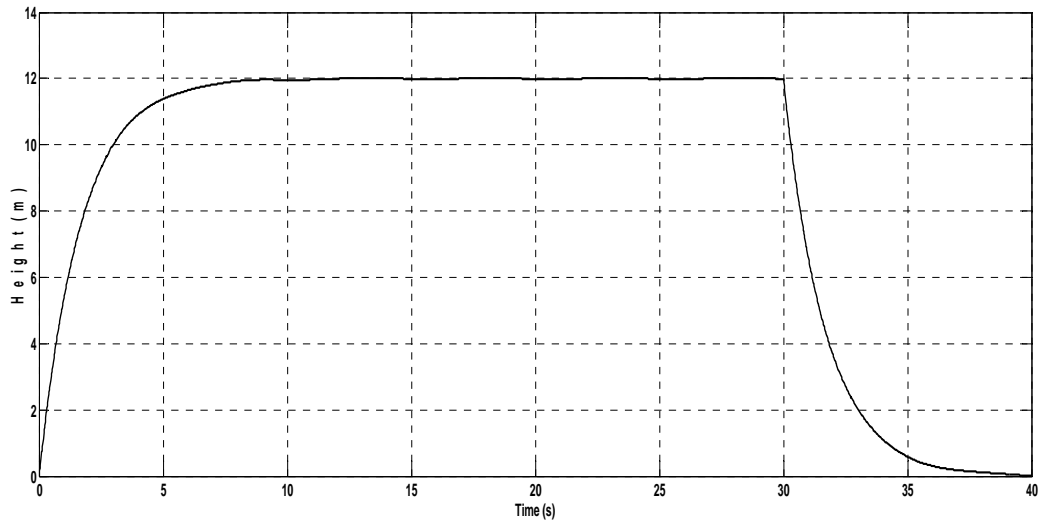

Fig. 2 Height trajectory of VTAV

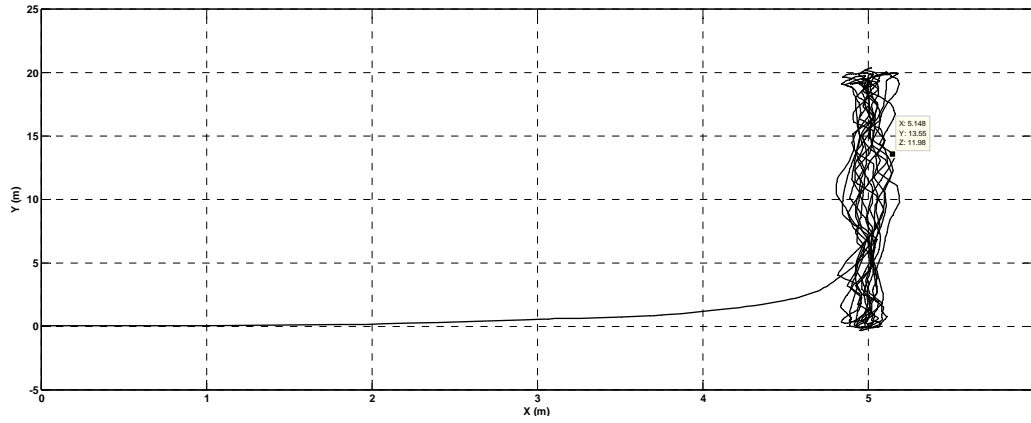

Fig. 3 X-Y view of VTAV's trajectory

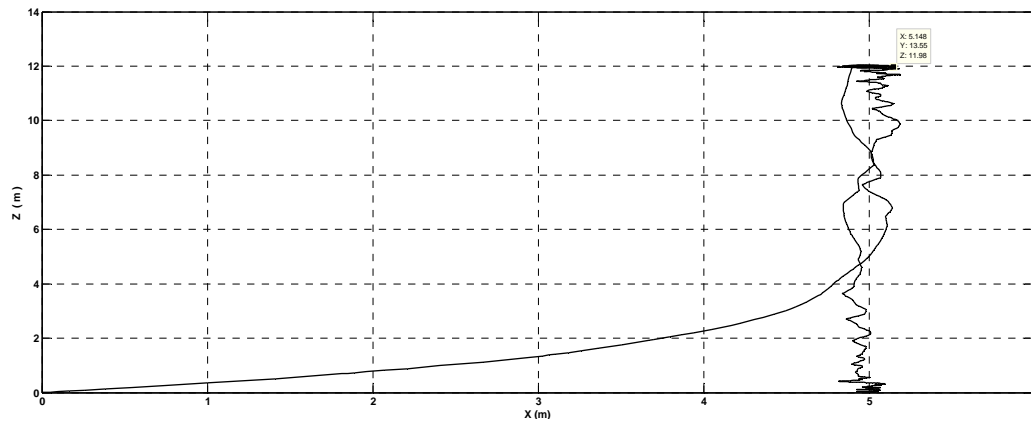

Fig. 4 X-Z view of VTAV's trajectory

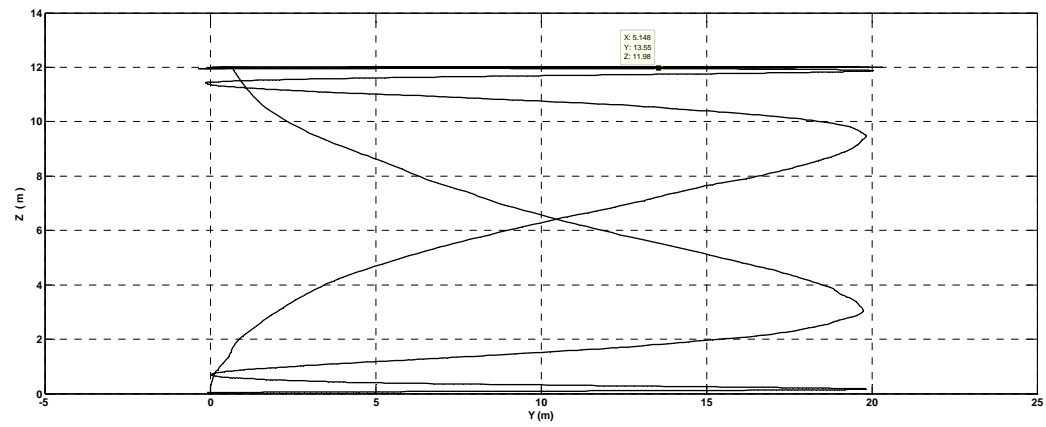

Fig. 5 Y-Z view of VTAV's trajectory

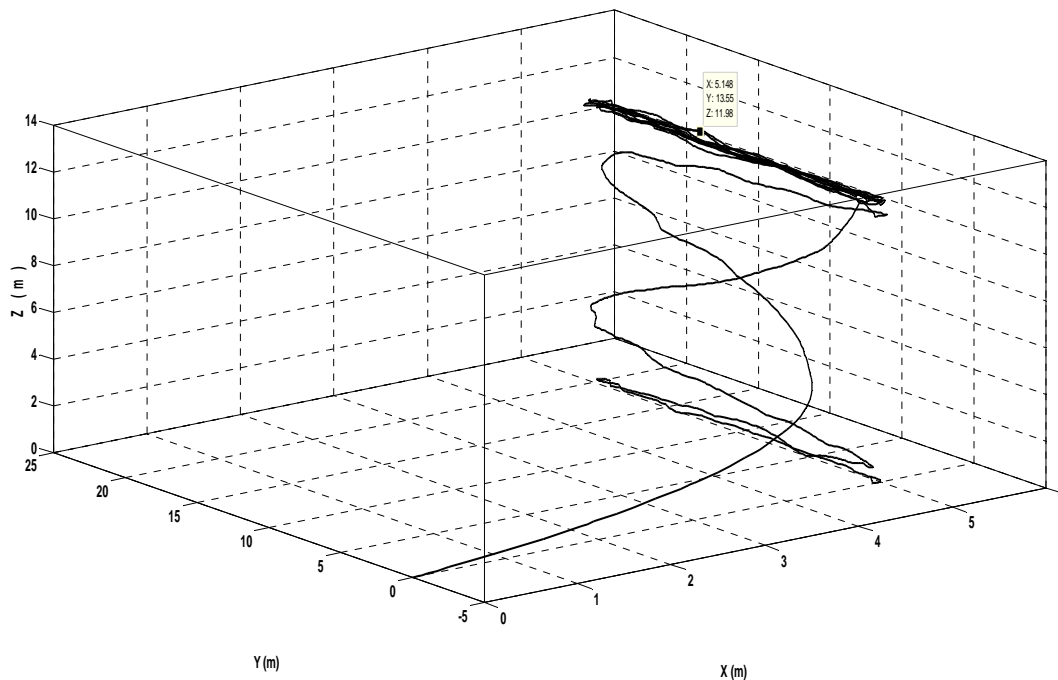

Fig. 6 3-D motion of VTAV

IV. CONCLUSIONS

A new research technique is presented in this paper for enhanced SA in possible missions of VTAV.

The need for highly reliable and stable flight maneuvers for VTOL class VTAVs has increased morbidly for critical situations in real-time search-and-rescue operations for fast SA.

For fast, stable and smooth flight maneuvers, we used a LQG controller. The effectiveness of this LQG control has been verified in field of flight simulation tests for chosen model of VTAV using software package Simulink.

From the applications viewpoint, we believe that this flexible and effective control furnishes a powerful approach for enhancing SA in applications to VTAV class aerial vehicles in real-time search-and-rescue operations.

Future work will involve further validation of the performance of the proposed research technique and exploring other relevant and interesting missions of VTAVs.

REFERENCES

- [1] M. R. Endsley, "Toward a theory of situation awareness in dynamic systems," *Human Factors*, vol. 37, pp. 32-64, March 1995.
- [2] J. Gorman, N. Cooke, and J. Winner, "Measuring team situation awareness in decentralized command and control environments," *Ergonomics*, vol. 49, pp. 1312-1325, October 2006.
- [3] Interim Brigade Combat Team Newsletter. [Online]. Available: http://www.globalsecurity.org/military/library/report/call/call_01-18_toc.htm
- [4] S. D. Prior, S. T. Shen, A. S. White, S. Odedra, M. Karamanoglu, M. A. Erbil, and T. Foran, "Development of a novel platform for greater situational awareness in the urban military terrain," in *Proc. 8th International Conf. Engineering Psychology and Cognitive Ergonomics*, San Diego, USA, 2009, pp. 120-125.
- [5] I. Astrov and A. Pedai, "Control of hovering manoeuvres in unmanned helicopter for enhanced situational awareness," in *Proc. International*

Conf. Industrial Mechatronics and Automation, Chengdu, China, 2009, pp. 143-146.

- [6] W. Yuan, H. Jayakody, and J. Katupitiya, "Dynamic modelling and analysis of a vectored thrust aerial vehicle," in *Proc. Australasian Conf. Robotics and Automation*, Wellington, New Zealand, 2012, pp. 1-8.