

Load Balancing in Genetic Zone Routing Protocol for MANETs

P. Sateesh Kumar , S. Ramachandram

Abstract—Genetic Zone Routing Protocol (GZRP) is a new hybrid routing protocol for MANETs which is an extension of ZRP by using Genetic Algorithm (GA). GZRP uses GA on IERP and BRP parts of ZRP to provide a limited set of alternative routes to the destination in order to load balance the network and robustness during node/link failure during the route discovery process. GZRP is studied for its performance compared to ZRP in many folds like scalability for packet delivery and proved with improved results. This paper presents the results of the effect of load balancing on GZRP. The results show that GZRP outperforms ZRP while balancing the load.

Keywords—MANET, routing, ZRP, Genetic algorithm, GZRP, load balancing

I. INTRODUCTION

A *Mobile Ad hoc Network* (MANET) [1] is a connectivity of network formed due to cooperation between the mobile nodes dynamically and instantaneously without depending on any of the fixed infrastructure like base stations. There are many challenges related to MANETs [2]. Some examples of the possible uses of ad hoc networking [3-4] include students using laptop computers to participate in an interactive lecture, business associates sharing information during a meeting, soldiers relaying information for situational awareness on the battlefield, and emergency disaster relief personnel coordinating efforts after a hurricane or earthquake. In such networks, each mobile node operates not only as a host but also as a router and cooperates dynamically to establish routing among them to discover “multi-hop” paths through the network to any other node.

There are various issues related to ad hoc networks [5-6]. Several protocols have been proposed for routing in such an environment. These protocols can broadly be classified into two types: *proactive* and *reactive* routing protocols. Proactive or *table-driven* protocols try to maintain routes to all the nodes in the network at all times by broadcasting routing updates in the network. Examples are Destination Sequenced Distance Vector (DSDV) [7], Optimized Link State Routing (OLSR), Wireless Routing Protocol (WRP) and Fisheye State Routing (FSR). On the other hand, reactive or *on-demand* protocols attempt to find a route to the destination, only when the source

has a packet to send to the destination. Examples are Dynamic Source Routing (DSR)[8], Adhoc On-demand Distance Vector (AODV), and Temporally Ordered Routing Algorithm (TORA). In between the above two extremes, there are the *hybrid* protocols. The Zone Routing Protocol (ZRP) [9] is a hybrid protocol. ZRP is a routing framework composed of the proactive Intrazone Routing Protocol (IARP)[10], reactive Interzone Routing Protocol (IERP)[11], and the Bordercast Resolution Protocol (BRP)[12]. IARP maintains routing information for nodes that are within the routing zone of the node. Correspondingly, IERP is a family of reactive routing protocols that offer enhanced route discovery and route maintenance services based on local connectivity monitored by IARP. As its name implies, ZRP is based on the concept of zones. Each node is defined with a separate routing zone and zones of neighboring nodes overlap. The routing zone has a radius, r , expressed in hops. The nodes of a zone are divided into *peripheral nodes* and *interior nodes*. Identification of a node's neighbors may be provided directly by the Media Access Control (MAC) protocols such as *Neighbor Discovery Protocol (NDP)*. All nodes proactively store local routing information and route requests can be more efficiently performed with *bordercasting*. Bordercasting utilizes the topology information provided by IARP to direct query request to the border of the zone. The bordercast packet delivery service is provided by the Bordercast Resolution Protocol (BRP). IERP uses the routing table of IARP to respond to route queries. IERP forwards queries with BRP. BRP uses the routing table of IARP to guide route queries away from the query source. There are studies [13-16] related to ZRP which prove that its performance is better compared to either table-driven or on-demand protocols. Authors of the paper have also made considerable performance study on ZRP. The results of the study are presented in [17-20].

Genetic Algorithms [21] perform much better with uneven conditions because of their population based approach spreading search throughout the possible alternatives. A large amount of work [21-30] has been done on the application of genetic algorithms or evolutionary algorithms to communications networks. Investigators have applied GAs to the shortest path (SP) routing problem [22-23]. C.W. Ahn et al [27] have proposed a GA approach for SP routing problem. It employs the variable length chromosomes. The crossover operation exchanges partial chromosomes (partial routes) at partially independent crossing sites and the mutation operation maintains the generic diversity of the population. A repair

P. Sateesh Kumar is with Department of CSE, Osmania University, Hyderabad as a Research Scholar (corresponding author; e-mail: kits.satish@gmail.com).

Dr. S. Ramachandram is with Department of CSE, Osmania University, Hyderabad as Professor of CSE; Director, University Computer Center; Member, IEEE).

function is used to cure the infeasible solutions due to crossover. The proposed protocol GZRP utilizes the new GA suggested in [27] with little changes which is proved to be fast compared to other GA-based methods.

The SP has to be computed within a very short time. Since GAs promise solutions to such complicated problems, they have been used successfully in various practical applications. In our approach, the proposed routing algorithm maintains a limited number of alternative routes which are frequently used in order to reduce communication overhead and end-to-end delay in routes while having better delivery of packets. We generate alternative routes by GA with genetic operators based on topological information of the network. These alternative routes generated by GA are use for distributing the packets in multiple paths in order to load balance the network.

This paper is organized as follows: In Section 2, provides the details and working of the protocol proposed by the authors, called Genetic Zone Routing Protocol (GZRP). Section 3 gives the experimental procedure including the evaluation methodology and environment used for the simulation, and in Section 4, we present the results of the experimented simulations. Section 5 gives the conclusions.

II. GENETIC ZONE ROUTING PROTOCOL

Genetic Zone Routing Protocol (GZRP) is proposed by the same authors in [32] which is an extension of Zone Routing Protocol (ZRP) adopting the concept of Genetic Algorithm (GA). GZRP is studied for its performance compared to ZRP in many folds like scalability for packet delivery and proved with improved results [33-35]. GZRP works like ZRP when the destination node is within the routing zone (or routing table) of the source node. The route to the destination is available in the routing table of the source node which is produced due to IARP. However, if the destination node is not found in the routing table of the source node, it initiates the route discovery process by sending Route Request (RREQ) packets with the help of IERP. These RREQ packets are bordercasted by BRP. Every border node searches for the destination node within its routing table. When a route to the destination is found, a Route Reply (RREP) packet is sent back to the source node.

The GZRP makes use of GA at each border node and generates possible alternative paths which may be optimal or sub-optimal. These alternative paths are stored at the border nodes for two basic reasons: (a) they can utilize these routes as the alternative routes in case of the existing route fails or node fails. (fault tolerance) (b) they can distribute the packets on multiple alternative routes to reduce the congestion and as well to balance the network (load balancing). At each border node, instead of bordercasting the RREQ packets on a primary path alone, they can be bordercasted on many routes. Even though, GA produces many possible alternative paths, we make use of limited number of alternative routes which are either optimal or near optimal. The architecture of the GZRP is shown in Fig.1.

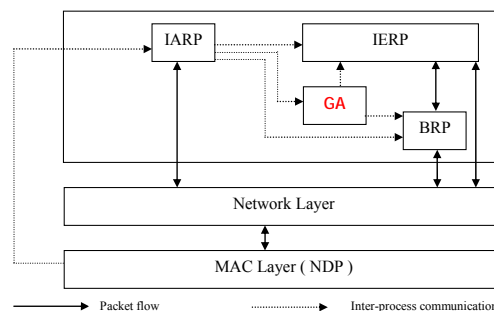

Fig. 1. Architecture of Genetic Zone Routing Protocol

While using GA in computing the shortest path or near shortest paths, it includes the process like crossover and mutation to produce the new routes. The GA used with GZRP is explained briefly below:

The first step in GA is to encode the elements of chromosomes. A chromosome of the GA consists of sequences of positive integers that represent the IDs of nodes through which a route path passes. The chromosome (border nodes of GZRP) representation is shown in Fig. 2. Each locus of the chromosome represents an order of a node (indicated by the gene of the locus) in a routing path. The gene of the first locus is always reserved for the source node. It never needs more than N number of nodes in a network to form a routing path. Hence, the maximum size of a chromosome length can be N. A chromosome (routing path) encodes the problem by listing up node IDs from its source node to destination node based on topological information (provided by IARP) of the network.

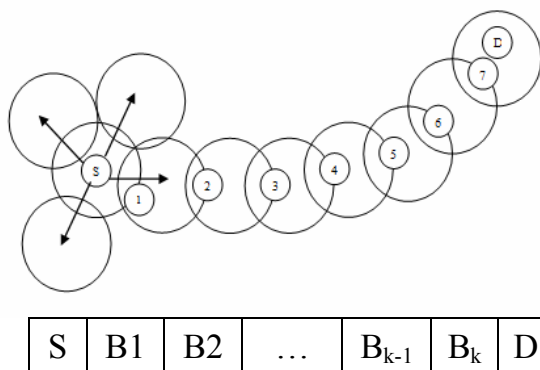

Fig. 2. Encoding method of border nodes

A population is created with a group of individuals (chromosomes) created randomly. These chromosomes in the population are evaluated. In this paper, the routing is applied on border nodes. Hence, the route length will be reduced in size compared to normal On-demand networks. This way, it reduces the population size of the network also. This work considered the population size as twice the number of nodes in the network. Further, the literature suggested that random initialization method can be adopted in order to generate the

new population.

The fitness function of GAs is generally the objective function that requires to be optimized. The fitness function in the SP routing problem is obvious because the SP computation amounts to finding the minimal cost path.

The selection (reproduction) operator is intended to improve the average quality of the population by giving the high-quality chromosomes a better chance to get copied into the next generation. However, the proposed GA technique employs the roulette wheel selection which is most widely used one.

Crossover examines the current solutions in order to find the better ones. Physically, crossover in the SP routing problem plays the role of exchanging each partial route of two chosen chromosomes in such a manner that the offspring produced by the crossover represents only one route. This dictates selection of one-point crossover as a good candidate scheme for the proposed GA. One partial route connects the source node to an intermediate node, and the other partial route connects the intermediate node to the destination node. In the proposed scheme, two chromosomes chosen for crossover should have at least one common gene (node) except for the source and destination nodes, but there is no requirement that they be located at the same locus. That is, the crossover does not depend on the position of nodes in routing paths. It is possible that loops are formed during crossover. A simple countermeasure must be taken this regard. Repair and penalty functions are the usual counter measures.

The population undergoes mutation by an actual change or flipping of one of the genes of the candidate chromosomes thereby keeping away from local optima. Physically, it generates an alternative partial-route from the mutation node to the destination node in the proposed GA. One of the nodes, connected directly to the node at mutation point, is chosen randomly as the first node of the alternative partial route.

As mentioned earlier, crossover may generate infeasible chromosomes that violate the constraints of generating loops in the routing paths. It must be noted that none of the chromosomes of the initial population or after the mutation is infeasible because when once a node is chosen, it is excluded from the candidate nodes forming the rest of the path.

A. Routing Table of a Border Nodes

Table I is a routing table generated at border node by IARP. It also makes use of GA to get primary route and as well the secondary routes or sub-optimal routes. The routing table consists of the entries including destination, route, frequency, and metric. The default metric used throughout the work is hop count. The destination entry indicates the destination node of packets. For each destination, we have a set of alternative routes. A route entry is a list of node IDs along the route. The frequency entry specifies the number of packets sent to the destination by the route.

TABLE I
A ROUTING TABLE AT BORDER NODE

Destination	route	frequency	metric
5	7-3-5	7000	Hop count
	7-2-6-5	2000	
	7-3-2-6-5	1000	
8	4-9-8	20000	Hop count
	4-5-8	18000	
...

B. Robustness: fault tolerance

Fault tolerance is essential in actual routing algorithms. It will take care of route maintenance. The routing algorithms must be robust for packet loss caused by instability of the network such as congestion and node/link failure. The GZRP reduces this problem by providing a set of alternative routes to a border node. The next best available alternative route at the border node is used for forwarding the packets. This gives robustness for the network and also reduces the control overhead that may occur in the network due to rediscovery of the routes.

C. Load Balancing

This frequency field in the routing table as shown in Table-I will be useful in order to load balance the network. This reduces the load on a single route by equally distributing the packet delivery through the available alternative routes as shown in Fig.3. The first route to the destination in the list is considered as the default route. In initial state, the routing table is empty. When a packet is generated at a node, a default route is generated by the IARP routing framework and will be inserted in to the routing table. This not only reduces the end-to-end delay but also helps in reducing the overhead. Further, delivery of the packets will be done more efficiently.

III. EXPERIMENTAL PROCEDURE

A. Evaluation Methodology

The simulator used for evaluation of the protocols is GloMoSim (Global Mobile Information System Simulator) [31]. The aim of this simulation study is to investigate the impact of scalability and node mobility on the performance of both the protocols, ZRP and GZRP with respect to load balancing. The effect of load balancing is evaluated with Coefficient of Variance, CoV.

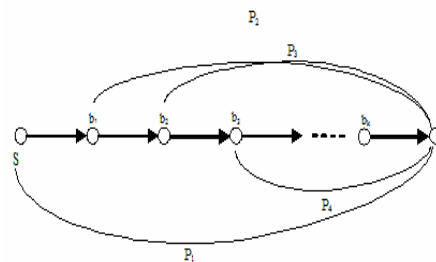

Fig. 3. Load balancing at border nodes

Load Balancing: We use a graph $G=(V, E)$ to denote the network, where V is the node set and E is the link set. We define a state function $f : V \rightarrow I$ where I is the set of positive integers. $f(v)$ represents the number of packets forwarded at node v . Let coefficient of variance, $CoV(f) = \text{standard variance of } f / \text{mean of } f$. We use $CoV(f)$ as a metric to evaluate the load balancing. The smaller the $CoV(f)$, the better is the load balancing.

B. Parameter used in the Simulation Model

The parameters used for modeling the simulation to evaluate the protocol are summarized in Table II and Table III summarizes the parameters used for GA. No data was collected for the first 10 seconds to avoid measurements before intra-zone route discovery process stabilized.

IV. RESULTS ANALYSIS

In this section, an analysis is made on the achieved results due to the performance evaluation of ZRP and GZRP with respect to load balancing. The results indicate that GZRP outperforms the ZRP due to load balancing. The study is concentrated particularly on the factors like mobility and scalability.

TABLE II
PARAMETERS OF SIMULATION

Parameter	Value
Simulation Time	900 s
Number of experimented trials	5
Network Coverage Area	1500 x 300 m ²
Number of Nodes	10-100
Routing Zone Radius	2
Mobility Model	Model: Random Way Point Pause Time: 0s, 100s, ..., 900s Minimum Speed: 1 m/s Maximum Speed: 20 m/s Node Placement : Random
Traffic	Source: CBR Number of Sources : 10 Rate: 1 packet/s Packet Size: 512 bytes
MAC	802.11
Bandwidth	2 Mbps
Transmission range	200m

TABLE III
PARAMETERS USED FOR GA

Parameter	Value
Crossover Rate	60%
Mutation Rate	0.5%
Population Size	2 times the Number of nodes
Selection	Roulette-Wheel method
Size of alternative routes in the routing table	3

A. Load Balancing Versus Mobility

The pause times are considered on X-axis to evaluate the performance of the protocol at various mobility conditions. A zero pause time means having high (continuously without break) mobility for the nodes. A low mobility (pause time is equal to the time of simulation) means the nodes are in near static environment. In between these two extremes, we have average mobility of the nodes. Fig.4 presents the comparative study of changes in CoV due to mobility of the nodes. At very high mobility conditions, both protocols behave similarly with GZRP providing better balance at around 13% improvement over ZRP. At very low mobility conditions, GZRP outperforms ZRP due to more available static routes compared to ZRP. In this case, GZRP provides around 27% improvement over ZRP. On the average, GZRP is better balanced near to 14% improvement over ZRP. The reason for this improvement is due to readily availability of alternative routes during the route failure or link failure conditions and also due to the availability of multiple (in our experiments, it is up to 3) routes through which packets are routed. This is a considerable achievement for GZRP.

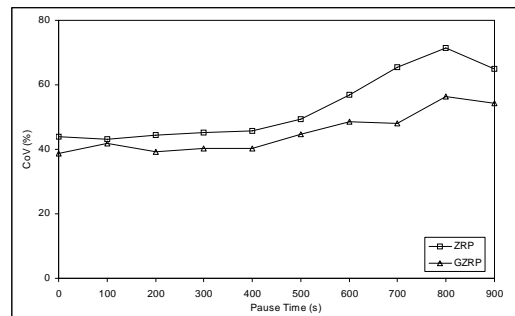

Fig. 4. load balancing versus mobility

B. Load Balancing Versus Scalability

The effect of load balancing on the scalability of the protocol is shown in Fig. 5. At an average GZRP has seen nearly 11% improvement over ZRP. It can also be seen that the deviation from the mean value is also very less for GZRP compared to ZRP. The network size (or the number of nodes in the network) is giving fewer imbalances over GZRP compared to ZRP. As the number of nodes increase, both the protocols are converging to a common value at around 50-60 nodes scenario. When the number of nodes is very less, GZRP outperforms ZRP with an improvement nearly 30%. However, both the protocols exhibit similar balancing when there are a large number of nodes in the network with an improvement of 20%.

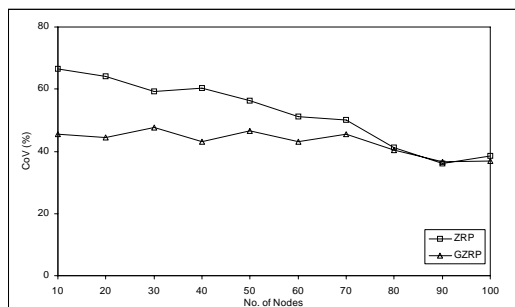

Fig. 5. load balancing versus network size

The imbalance is better explained through Fig. 6. The dashed line represents the desired output i.e. the required balancing factor. ZRP deviates a lot from the desired output and expands on either sides of the dashed line. It can perform well in the near range of network size with 50-60 nodes. GZRP performs almost near to desired values i.e. dashed line. This implies that GZRP can be a good choice for load balancing protocol apart from its regular performance.

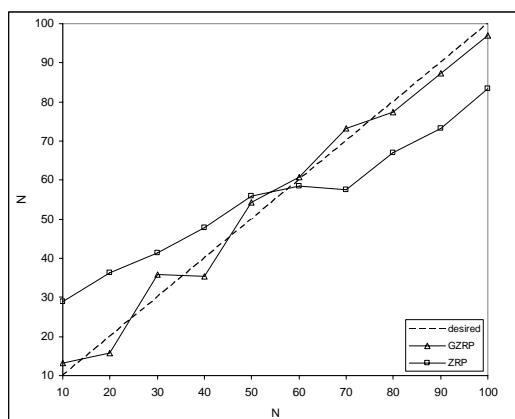

Fig. 6. Load balance Deviation of ZRP and GZRP from the desired value

V. CONCLUSIONS

In this paper, we have presented the performance evaluation of Genetic Zone Routing Protocol (GZRP) which is an extension to the Zone Routing Protocol (ZRP) with the use of genetic algorithm (GA). GZRP is more efficient compared to ZRP as it reduces considerably the average end-to-end delay and control overhead. The results indicate that GZRP is well balanced protocol compared to ZRP due to mobility of the nodes and number of the nodes in a network is concerned. On the whole, the GZRP is giving an improvement of 14% and 11% due to mobility and scalability. Its load balancing nature and fault tolerance nature provided a set of alternative routes without requiring for more route discoveries.

REFERENCES

[1] National Science "Foundation. Research priorities in wireless and mobile communications and networking"; *Report of a workshop held;*

- March 24-26, 1997, Airlie House, Virginia, Available at <http://www.cise.nsf.gov/anir/ww.html>
- [2] R. Ramanathan and J. Redi, "A brief overview of ad hoc networks: challenges and directions", *IEEE Communications Magazine*, 40(2):20-22,2002
- [3] Schiller, J.H; *Mobile Communications*, Pearson Education, India, 2001
- [4] William Stalings; *Wireless communications and Networks*. Prentice Hall, New Jersey, 2000
- [5] Elizabeth, Royer, Chai-Keong, Toh: "A Review of Current Routing Protocols for Ad hoc Mobile Wireless Networks", *IEEE Personal Communications*, April 1999.
- [6] Frank, McSherry, Gerome, Miklau, Don, Patterson, Steve, Swanson:"The Performance of Ad hoc Networking Protocols in Highly Mobile Environments", *Spring 2000*, Washington.
- [7] Perkins, C.E, Bhagwat,P: "Highly Dynamic Destination Sequenced Distance Vector Routing (DSDV) for Mobile Computers", *Computer Communications*, October, pp234-244, 1994
- [8] David B. Johnson. Routing in Ad Hoc Networks of Mobile Hosts. Proceedings of the Workshop on Mobile Computing Systems and Applications, *IEEE Computer Society, Santa Cruz, CA, December*, pp. 158-163, 1994
- [9] Haas, J., "A new routing protocol for the reconfigurable wireless networks", *Proc. of IEEE Int. Conf. on Universal Personal Communications*, pp. 562-566, 1997
- [10] Haas, Zygmunt J, Pearlman, Marc R, Samar, P; "Intrazone Routing Protocol (IARP)", June 2001, *IEFT internet Draft*, draft-ietf-manet-iarp-01.txt
- [11] Haas, Zygmunt J, Pearlman, Marc R, Samar, P; "Interzone Routing Protocol (IERP)", June 2001, *IEFT internet Draft*, draft-ietf-manet-ierp-01.txt
- [12] Haas, Zygmunt J, Pearlman, Marc R, Samar, P; "Bordercast Resolution Protocol (BRP)", June 2001, *IEFT internet Draft*, draft-ietf-manet-brp-01.txt
- [13] Pearlman, Marc R, Hass, Zygmunt J; "Determining the Optimal Configuration for the Zone Routing Protocol", *IEEE Journal on Selected Areas in Communications*, Vol 17, No. 8, August 1999
- [14] Hass, Zygmunt J, Pearlman, Marc R: "Providing ad-hoc Connectivity With Reconfigurable Wireless Networks", *Ithaca, New York* available at <http://www.ee.cornell.edu/~haas/wnl.html>
- [15] Hass, Zygmunt J, Pearlman, Marc R: "The Performance of Query Control Schemes for the Zone Routing Protocol", *IEEE/ACM Transactions on Networking*, August 2001, , Vol 9 No. 4
- [16] Prasun, Sinha, Srikanth, Krishnamurthy, Son, Dao: "Scalable Unidirectional Routing with Zone Routing Protocol (ZRP) Extensions for Mobile Ad hoc Networks". *IEEE Conf. Wireless Comm. and networking*, pp. 1329-1339, 2000.
- [17] P. Sateesh Kumar, S. Ramachandram and C.R. Rao, "Effect of Transmission Range on the Performance of Zone Routing Protocol in MANETs", *Proc. ICACC*, pp. 627-630, 2007.
- [18] P. Sateesh Kumar, and S. Ramachandram, "Performance Studies on the various routing protocols in Ad hoc Networks", *Int. Jrl. Of Scientific Computing*, vol.2, No.1, pp. 83-91, Jun. 2008.
- [19] P. Sateesh Kumar, S. Ramachandram, and C.R. Rao, "Impact of Node mobility and Network size on the performance of ZRP in MANETs", *Proc.ObCom, 2006*
- [20] P. Sateesh Kumar, P. Suresh Kumar, and S. Ramachandram, "A modified timer based caching technique for ZRP", *Conf. ICAC*, 2008.
- [21] D.E. Goldberg, *Genetic Algorithms in Search, Optimization, and Machine Learning*. Reading, MA: Addison-Wesley.
- [22] M. Munemoto, Y. Takai, and Y. Sato, "A migration scheme for the genetic adaptive routing algorithm", *Proc. IEEE Int. Conf. Systems, Man, and Cybernetics*, 1998, pp2774-2779.
- [23] J. Inagaki, M. Haseyama, and H. Kitajima, "A genetic algorithm for determining multiple routes and its applications", in *Proc. IEEE Int. Symp. Circuits and Systems*, 1999, pp. 137-140.
- [24] Y. Leung, G. Li, and Z.B. Xu, "A genetic algorithm for the multiple destination routing problems", *IEEE Trans. Evol. Comput.*, vol. 2, pp. 150-161, Nov. 1998.
- [25] Z. Xiawei, C. Changjia, and Z. Gang, "A genetic algorithm for multicasting routing problem", *Proc. Int. Conf. Communication Technology (WCC-ICCT 2000)*, 2000, pp. 1248-1253.
- [26] D. Montana, and J. Redi, "Optimizing Parameters of a Mobile Ad hoc Network Protocol with a Genetic Algorithm", 2006.

- [27] C. W. Ahn, and R.S. Ramakrishna, "A Genetic Algorithm for Shortest Path Routing Problem and the Sizing of Populatioon", *IEEE Trans. On Evol. Comput.* Vol.6, No.6, Dec. 2002.
- [28] E. Sozer, M. Stojanovic, and J. Proakis, "Initialization and routing optimization for ad-hoc under water acoustic networks", *Proc. Of Oponetwork*, 2000.
- [29] A. Roy and S. Das, "QM2RP: A QoS-based mobile multicast routing protocol using multi-objective genetic algorithm", *Wireless Networks*, 10(3): 271-286, 2004.
- [30] D. Turgut, S. Das, R. Elmasri, and B. Turgaut, "Optimizing clustering algorithm in mobile ad hoc networks using genetic algorithm approach", *Proc. Of IEEE Global Telecommunications Conf.*, 21(1), pp.62-66, 2002.
- [31] GloMoSim: "Global Mobile Information Systems Simulation Library" available at <http://pcl.cs.ucla.edu/projects/glomosisim>.
- [32] P. Sateesh Kumar and S. Ramachandram, "Genetic Zone Routing Protocol", *Int. Jrl. of Theoretical and appl. Infn. Tech.*, 4(9), pp 789-794, Sept. 2008.
- [33] P. Sateesh Kumar and S. Ramachandram, "Scalability of Network Size on Genetic Zone Routing Protocol of MANETs", *IEEE Proc. of ICACTE-2008*, Thailand, Dec. 2008.
- [34] P. Sateesh Kumar and S. Ramachandram, "The Performance Evaluation of Genetic Zone Routing Protocol", *IEEE Proc. of TENCON-2008*, India, . Nov. 2008
- [35] P. Sateesh Kumar and S. Ramachandram, "The Performance Evaluation of Cached Genetic Zone Routing Protocol for MANETs", *IEEE Proc. of ICON 2008*, India, Dec 2008.



P. Sateesh Kumar is a Life Member (LM) of IAENG, IIS, ISTE, IETE, and CSI. He is the Senior Member (SM) of IACSIT. He is born in Warangal city of India. He acquired his M.Sc.in Physics with a specialization in Electronics in 1995 from Kakatiya University, Warangal, India, M.Tech in CSE in 2003 from Osmania University, Hyderabad, India and currently pursuing Ph.D from the same University.

He is currently working in Vaagdevi College of Engineering, Warangal, India as Associate Professor of CSE. Earlier, he worked in Kamala Institute of Technology & Science, Karimnagar, India. He has over 12 years of teaching and research experience. He has many publications in Journals and Conferences. Some of them are published in IEEE Xplore. He has been the Member Editor of International Journal of Computers and Electrical Engineering. He has worked as TPC Members for many conferences. He was the Member Editor for Proceedings of National Conference on Mobile Computing. Currently, he is a TPC Member of a IEEE Conference on ITRWP. His research interests include the Mobile Ad-hoc Networks, Grid Computing and Cloud Computing.



S. Ramachandarm is Professor of Dept of Computer Science and Engineering, University College of Engineering, Osmania University, Hyderabad, India. He is an **IEEE** Member and Life Member of many professional Societies like ISTE, IETE and CSI. He is born in Nalgonda city of India. He has done his B.Tech in Electronics, M.Tech in Computer Science & Engineering and Ph.D in Computer Science & Engineering from Osmania

University, Hyderabad, India. He has organized and involved in many Conferences and Member Editor for many Journals. He acted as Chair and Co-Chair for many International Conferences. His research areas include Mobile Computing, Distributed Computing and Grid Computing. He guided many Post Graduate and Ph.D scholars. Currently, he is the Head of the Department of Computer science and Engineering.

He authored two books and published many papers both in Journals and conferences. Many of them are published in IEEE Xplore. He was Project coordinator for establishing Campus wide Network in Osmania University and he is instrumental in modernizing and automation of Examination Branch of Osmania University, Hyderabad, India.