

Layout Design Optimization of Spars under Multiple Load Cases of the High-Aspect-Ratio Wing

Yu Li, Jingwu He, Yuexi Xiong

Abstract—The spar layout will affect the wing's stiffness characteristics, and irrational spar arrangement will reduce the overall bending and twisting resistance capacity of the wing. In this paper, the active structural stiffness design theory is used to match the stiffness-center axis position and load-cases under the corresponding multiple flight conditions, in order to achieve better stiffness properties of the wing. The combination of active stiffness method and principle of stiffness distribution is proved to be reasonable supplying an initial reference for wing designing. The optimized layout of spars is eventually obtained, and the high-aspect-ratio wing will have better stiffness characteristics.

Keywords—Active structural stiffness design theory, high-aspect-ratio wing, flight load cases, layout of spars.

I. INTRODUCTION

DIFFERENT wing configurations may build up various kind of fixed-wing aircraft, and these aircraft always are used in their separate conditions, including the proper flight height and speed.

Especially, the high-aspect-ratio wing is universally used in high altitude environment with subsonic flight speed, which has less induced drag and is more aerodynamically efficient, because of its long and slender shape. In modern times, the high-aspect-ratio wing is widely used in solar-powered aircraft and high-performance sailplanes. Therefore, it is necessary to optimize its configuration.

The active stiffness design method [1] is put forward in the preliminary stage of structural design, with which the wing stiffness characteristics are analyzed and calculated, providing guidance for the subsequent design process. Then, a better wing configuration can be designed meeting the stiffness characteristic requirements, and thus the structural potential is realized.

In this paper, the active stiffness design method and the principle of stiffness distribution are used to optimize the layout of the high-aspect-ratio wing spars.

II. STUDY OBJECTIVE

In this paper, a rectangular high-aspect-ratio wing will be taken as an example, and the layout of spars will be discussed

Yu Li is with the Beihang University, Beijing, BJ 100191 CHN (corresponding author, phone: 18810344761, e-mail: 18234085592@163.com).

Jingwu He, is with the School of Aeronautic Science and Engineering, Beihang University, Beijing, BJ 100191 CHN (e-mail: hejingwu@buaa.edu.cn).

Yuexi Xiong is with the School of Aeronautic Science and Engineering, Beihang University, Beijing, BJ 100191 CHN (e-mail: yxiong@buaa.edu.cn).

based on active stiffness design method. The rectangular wing has constant chord length and parallel leading as well as trailing edges, of which the structure is simple. Taking the rectangular wing as the study object, the calculation could be simplified, and the optimization theory can be described more clearly.

This wing, having SG6042 airfoil, 10-meter wingspan, double beams, and aspect ratio $\lambda = 11.1$, is mounted on a solar-powered aircraft that will carry out missions at high altitude and low speed cruise state.

Due to the symmetry of wing forces, the half-wing is taken as the research object, which is shown in Fig. 1.



Fig. 1 Half-wingspan model

III. ACTIVE STIFFNESS DESIGN METHOD

A. Active Stiffness Design Method

The active stiffness design method is proposed in accordance with the existing strength-based design method of the aeroplane structure.

In modern structural design, the strength indexes are put forward at the initial structural design phase and run through the whole design process, by which the structure is judged whether to meet the requirements for engineering applications. But, the stiffness indexes are not checked until the design is completed, and the structure designed may be not up to the stiffness standard. Thus, the re-design, even from the initial stage, is inevitable, resulting in the heavy workload. In terms of the high-aspect-ratio wing, its stiffness is low especially in the wing-span direction. So, the active stiffness design method is used to design wing configuration and optimize the spar layout.

B. Rigid Line

The stiffness center is a point that forces run through without producing any torque on the corresponding cross-section. All stiffness centers on each cross section are connected into a line, called rigid line.

The rigid line is one of stiffness indexes for wing, the position of which is calculated out to match multiple flight load cases [2]. And the force condition of wing can be improved under various flight states. The high-aspect-ratio airplane is in

cruise state for a long period, and is in flight turbulence for a short time, the load of these two cases is shown in Fig. 2.

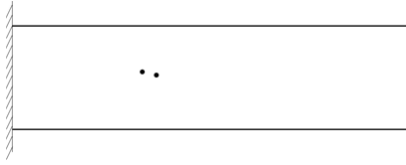

Fig. 2 Position of flight cases

In the two flight states, the magnitude and position of external loads are different, and the rigid line cannot pass all the points of resultant forces. Therefore, the external load points do not always coincide with the rigid line, and the wing is not only subject to shear and bending moments but also the twisting moment relative to the stiffness center. Due to the presence of torque, the wing will have a torsional deformation, which causes a problem of aero elasticity [3]. So, placing the rigid line where the twisting moment will be minimized for all load cases is reasonable.

C. Rigid Line Designing

In the two given conditions, the flight height and speed are considered for the solar-powered airplane. The size and position of the aerodynamic forces can be calculated by using the FLUENT software (see Table I). Then, a mathematical model is established, and the rigid line position matches the various flight load cases.

TABLE I
AERODYNAMIC FORCE IN TWO KINDS OF FLIGHT STATES

	cruise state	vertical gust state
magnitude of aerodynamic force (N)	196.4	491.35
point of aerodynamic force (mm)	(2.3361,0.5218)	(2.3338,0.5084)

Firstly, it is assumed that the rigid line is a straight line for the semi-wingspan in order to simplify the calculation in the early designing stage.

A plane coordinate system, shown in Fig. 3, is established for the parameters of the half-wing, where the origin is at the intersection of the wing root and the trailing edge, the x-axis is along with the wing-span, and the y-axis points at the leading edge from the origin.



Fig. 3 Coordinate system of the rigid line

The equation of the rigid line is,

$$y = kx + b \tag{1}$$

where the k and b are design variables, and the x and y are coordinate values.

If values of k and b are set to be reasonable, that is, the location of the rigid line is appropriate, the aerodynamic torque will be relatively small.

Secondly, an objective function of k and b is set to solve this problem.

Objective function,

$$\min_{(k,b)} \{ \sum \lambda_i |T_i| \} \quad (i = 1, 2) \tag{2}$$

where

$$T_i = F_i \frac{|kx_i + b - y_i|}{\sqrt{1 + k^2}} \tag{3}$$

Thirdly, constraint conditions are chosen to restrict the location of the rigid line according to engineering experience. Referred to the *Aircraft Design Manuel*, the front and rear beams are arranged between 15% and 60% of the wing chord, so,

$$\begin{cases} |k| \leq 0.081 \\ 0.36 \leq b \leq 0.765 \\ 0.36 \leq 5k + b \leq 0.765 \end{cases} \tag{4}$$

Finally, the multi-objective optimization model is,

$$\min_{(k,b)} \{ \sum \lambda_i |T_i| \} \quad (i = 1, 2) \tag{5}$$

$$\min_{(k,b)} \{ \lambda_1 T_1 + \lambda_2 T_2 \} = \frac{1}{\sqrt{1+k^2}} \cdot [\lambda_1 (F_1 |kx_1 + b - y_1|) + (F_2 |kx_2 + b - y_2|)] \tag{6}$$

where $\lambda_1 = 0.95, \lambda_2 = 0.05$.

$$\text{st.} \begin{cases} |k| \leq 0.081 \\ 0.36 \leq b \leq 0.765 \\ 0.36 \leq 5k + b \leq 0.765 \end{cases} \tag{7}$$

The data shown in Table I are substituted into the optimization model to calculate and obtain the optimal solution by MATLAB software. Thus, the rigid line equation is

$$y = 0.0011x + 0.5192 \tag{8}$$

The rigid line is always located between the 35% and 45% of the wing chord by passive stiffness design method [4]. In this paper, the rigid line lies in about 42.31% of the chord by adapting to flight load cases using active stiffness method. That is, this method is reasonable enough to be an initial reference for wing designing.

IV. PRINCIPLE OF STIFFNESS DISTRIBUTION

This paper mainly discusses the distribution of spars, assuming that the ribs are evenly arranged and the thickness of the skin-panel is equal, on the basis of the controlling variable method.

The rigid line has been obtained in the above analysis, and the spars will be arranged according to the position of the rigid line and the principle of stiffness distribution.

In terms of the wing with double beams, the front and rear beams bear bending moment. And the closed cabin, consisting of spars and skins, is mainly subjected to the aerodynamic torque, whose size and average height depend on the position of the spars for the wing of a given airfoil.

In order to study the stiffness distribution theory and evolutionary computation, the wing uses beams with rectangular section. It is assumed that the aerodynamic force on the stiffness center is P , and the forces of the front and rear spars are P_1 and P_2 at the wing root section, shown in Fig. 4. Inertia moments of the front and rear spars are assumed to be I_1 and I_2 . The same material is chosen for the both beams, so elastic modulus is E . Therefore, the stiffness of the beams is E_1 and E_2 , respectively. According to the force equilibrium equation,

$$\begin{cases} P = P_1 + P_2 \\ P_1 : P_2 = E_1 : E_2 \end{cases} \quad (9)$$

then,

$$\begin{cases} P_1 = E_1 \times \frac{P}{E_1 + E_2} = \omega P \\ P_2 = E_2 \times \frac{P}{E_1 + E_2} = (1 - \omega) P \end{cases} \quad (10)$$

where ω is the stiffness distribution coefficient of the front beam based on the principle of stiffness distribution.

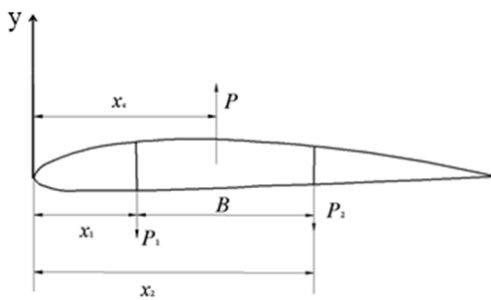

Fig. 4 Stiffness distribution

V. THE OPTIMIZATION MODEL FOR THE LAYOUT OF WING SPARS

A. Equation of SG6042 Airfoils

With the ascending in spars pitch spacing, the cross-sectional area of the closed cabin increases, called the anti-twist box, which enhanced the wing's torsional resistance ability. But, the

reduction in the height, that is, the stiffness of the spars, weakens the bending resistance ability of the wing. So, it is necessary to arrange a set of spars better so that the wing has a good performance in withstanding bending and torsion moment. This is also a multi-objective optimization problem.

A two-dimensional coordinate system is created at the wing root profile with the SG6042 airfoil. The airfoil is fitted from the coordinates values derived from the PROFILI software (see Table II), where the origin point is at the leading edge, the x-axis is along with the chord, and the y-axis points up.

TABLE II
AIRFOIL COORDINATE VALUES (UNITS: MM)
SG6042

Upper surface		Lower surface	
x	y	x	y
900	0	0	0
898.254	0.42882	0.315	-4.70643
893.241	1.81470	3.339	-8.20192
885.348	4.14033	9.612	-10.9985
874.890	7.25330	18.612	-13.4031
862.056	10.93794	30.321	-15.2268
846.918	14.95139	44.838	-16.4874
829.449	19.20360	62.109	-17.2840
809.712	23.74868	82.053	-17.7337
787.914	28.55100	104.499	-17.8818
764.235	33.55691	129.285	-17.7917
738.882	38.70377	156.222	-17.4817
712.053	43.88394	185.130	-16.9971
683.955	49.00780	215.811	-16.3562
654.813	53.89576	248.031	-15.5776
624.690	58.39494	281.574	-14.6795
593.658	62.49646	316.215	-13.6715
561.915	66.13768	351.702	-12.5719
529.596	69.27386	387.801	-11.3632
496.872	71.90531	424.260	-10.0099
463.914	73.99633	460.872	-8.47621
430.893	75.52023	497.493	-6.77156
397.989	76.48634	533.970	-4.94117
365.373	76.85898	570.105	-3.05741
333.216	76.67445	605.682	-1.22866
301.698	75.91509	640.449	0.44562
270.990	74.59020	674.136	1.88393
241.272	72.73612	706.446	3.04073
212.697	70.35311	737.100	3.86152
185.427	67.45048	765.837	4.34582
159.615	64.07350	792.369	4.49311
135.396	60.23142	816.462	4.31196
112.896	55.97847	837.873	3.86493
92.241	51.32388	856.377	3.19661
73.521	46.31281	871.812	2.40570
56.844	40.99945	884.016	1.57291
42.282	35.38395	892.836	0.79696
29.835	29.53830	898.200	0.23072
19.611	23.55269	900	0
11.556	17.45403		
5.571	11.38614		
1.773	5.53823		
0	0		

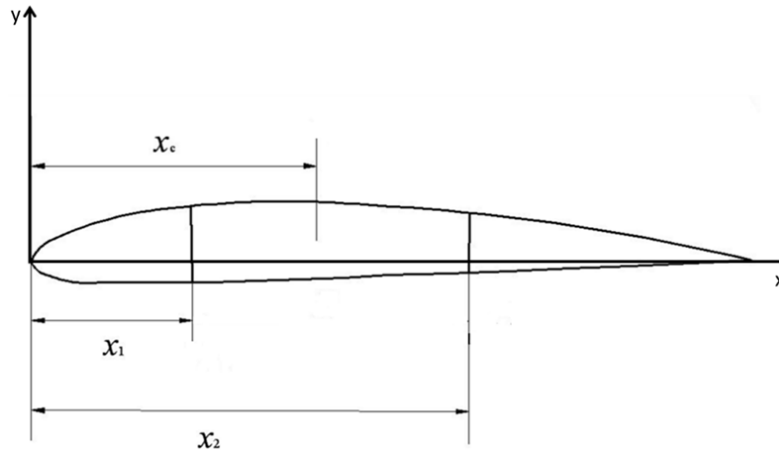

Fig. 5 Coordinate system for airfoil equations

In Fig. 5, x_1 is the coordinate value of the front beam, x_2 is the coordinate value of the rear beam, and x_c is the coordinate value of the stiffness center at wing root section, which has been gained in the above paragraphs. Then, a mathematical model can be established to optimize the layout of spars.

Firstly, it is assumed that the thickness of the rectangular beams is constant, and the stiffness index B can be converted to the height parameter h . And the airfoils of the upper and lower surfaces are fitted with quadratic polynomial to calculate the beam height.

The function of the upper half of the airfoil curve is,

$$y_u(x) = -7.942 \times 10^{-10}x^4 + 1.694 \times 10^{-6}x^3 - 0.001503x^2 + 0.5469x + 9.929 \quad (11)$$

The function of the lower half of the airfoil curve is,

$$y_l(x) = -6.046 \times 10^{-11}x^4 - 0.1097 \times 10^{-6}x^3 + 0.0002641x^2 - 0.0972x - 6.276 \quad (12)$$

The function of the beam height is,

$$h(x) = y_u(x) - y_l(x) = -7.3374 \times 10^{-10}x^4 + 1.8037 \times 10^{-6}x^3 - 1.7671 \times 10^{-3}x^2 + 0.6441x + 16.205 \quad (13)$$

Secondly, the coordinate relations between beams and stiffness center can be gotten by the moment equilibrium equation,

$$P_1(x_c - x_1) = P_2(x_2 - x_c) \quad (14)$$

Combined with the force equilibrium equation, then optimization variables are x_1 and ω ,

$$x_2 = \frac{x_c - \omega x_1}{1 - \omega} = \frac{0.4039 - \omega x_1}{1 - \omega} \quad (15)$$

Finally, the cross sectional area of the anti-twist box, which represents the wing's torsional resistance ability, can be calculated with these parameters,

$$A = \int_{x_1}^{x_2} (y_u - y_l) dx \approx \frac{1}{2} (h_1 + h_2) (x_2 - x_1) \quad (16)$$

where h_1 is the height of the front beam, and h_2 is the height of the rear beam.

B. The Multi-Objective Optimization Model

The mathematical model for this multi-objective optimization problem is,

$$\max_{(x_1, \omega)} \{h_1(x_1, \omega), h_2(x_1, \omega), A(x_1, \omega)\} \quad (17)$$

In this optimization problem, the h_1 , h_2 and A are expected to be maximum, but the increasing of A would lead to the descending of the beam height h , and vice versa. So, there is a necessity that the spurs position is planned to make the wing's bending-torsion resistance ability reasonable.

For a multi-objective optimization problem, a unified objective function is required for design variables. Solving the maximum value of each sub-objective function h_1^0 , h_2^0 and A^0 first, then the weighted square method is used to establish the objective function and make it minimized to approach respective maximums.

Objective function,

$$\min_{(x_1, \omega)} \{ \lambda_1 (h_1 - h_1^0)^2 + \lambda_2 (h_2 - h_2^0)^2 + \lambda_3 (A - A^0)^2 \} \quad (18)$$

where λ_1 , λ_2 and λ_3 are the weight coefficients, meeting

$$\begin{cases} \lambda_1 + \lambda_2 + \lambda_3 = 1 \\ \lambda_1 \geq 0 \\ \lambda_2 \geq 0 \\ \lambda_3 \geq 0 \end{cases} \quad (19)$$

and $\lambda_1 = 0.5$, $\lambda_2 = 0.1$ and $\lambda_3 = 0.4$ here.

Constraint conditions are chosen depending on design experience, such that the front beam is usually placed between 15% and 35% of the chord, the rear beam is mounted between 50% and 60% of the chord, and the front beam is always the main beam which has bigger stiffness and bears greater force for the high-aspect-ratio wing. So

$$\begin{cases} 135 \leq x_1 \leq 315 \\ 450 \leq x_2 = \frac{x_c - \omega x_1}{1 - \omega} \leq 540 \\ 0.5 \leq \omega \leq 1 \end{cases} \quad (20)$$

The maximum values of each sub-objective can be gained under these constraints.

$$h_1^0 = \max \{h_1\} = 93.1849 \quad (21)$$

$$h_2^0 = \max \{h_2\} = 82.4865 \quad (22)$$

$$A^0 = \max \{A\} = 2.4710 \times 10^4 \quad (23)$$

Eventually, the optimization model for the layout of spars is objective function

$$\min_{(x_1, \omega)} \left\{ \lambda_1 (h_1 - h_1^0)^2 + \lambda_2 (h_2 - h_2^0)^2 + \lambda_3 (A - A^0)^2 \right\} \quad (24)$$

$$\min_{(x_1, \omega)} \left\{ \begin{array}{l} 0.4 \times (h(x_1) - 93.1849)^2 \\ +0.2 \times (h(x_2) - 82.4865)^2 \\ +0.4 \times (A(x_1, \omega) - 2.2210 \times 10^4)^2 \end{array} \right\} \quad (25)$$

st.

$$\begin{cases} 135 \leq x_1 \leq 315 \\ 450 \leq x_2 = \frac{x_c - \omega x_1}{1 - \omega} \leq 540 \\ 0.5 \leq \omega \leq 1 \end{cases} \quad (26)$$

then,

$$\begin{cases} x_1 = 233.8462 \\ \omega = 0.52 \end{cases} \quad (27)$$

The computation results of the optimization process can be obtained by the MATLAB software [5]. The front beam is located in 30% of the chord line, and the rear beam lies in 54% of the wing chord, which is coincided with the designing experience.

VI. CONCLUSION

High-aspect-ratio wings have low stiffness, especially at its wingspan direction, hence the rigid line is calculated out at the original stage by active stiffness method to meet the stiffness

requirement. Then, the principle of stiffness distribution guides the spar layout.

- 1) Active stiffness design method could supply reference stiffness indexes, and help to improve the efficiency structural design.
- 2) Rigid line is one of the wing's stiffness characteristics, with which the layout of the spars could be designed better.
- 3) The flight load cases are various according to the solar-powered aircraft flight state. The position of the rigid line can be optimized by matching these load cases.
- 4) The principle of stiffness distribution is the basis of optimizing the layout of spars, on which the stiffness index is applied to this optimization process.
- 5) In terms of the multi-objective optimization model, it is important to unify its sub-objective functions though some ways, and obtain the final conclusion.

REFERENCES

- [1] Xia Sheng-lai, He Jing-wu, Hei Li-jie, "Study on the Method of Active Structural Stiffness Design," *Aircraft Design*, 2012, vol. 3, pp. 19-23.
- [2] Xu YanShen, Xu Qianli, Chen Yongliang, Hou Liang, "Research on the generalized modular design method with flexible modules of product structures," *Chinese Journal of Mechanical Engineering*, 2004, vol. 4, pp. 477-480.
- [3] Z. C. Yang, H. Zhang, G. U. Ying-Song, M Song, "Aeroelastic analysis of the high aspect ratio wing considering the geometric nonlinearity," *Journal of Vibration*, 2006, vol. 6, pp. 32-33+53.
- [4] *Aircraft Design Manual* (Chinese Aviation Industry Press, 2000, vol. 10, pp. 333-362).
- [5] Y. L. Liu, D. M. Guo, Y. I. Xian-Zhong, Optimum Design of Mechanism based on Matlab Optimization Toolbox (J), *Modern Machinery*, 2006, vol. 6, pp. 32-33+53.