

# Investigation of Transmission Line Overvoltages and their Deduction Approach

A. Hayati Soloot, A. Gholami, E. Agheb, A. Ghorbandaeipour, and P. Mokhtari

**Abstract**—The two significant overvoltages in power system, switching overvoltage and lightning overvoltage, are investigated in this paper. Firstly, the effect of various power system parameters on Line Energization overvoltages is evaluated by simulation in ATP. The dominant parameters include line parameters; short-circuit impedance and circuit breaker parameters. Solutions to reduce switching overvoltages are reviewed and controlled closing using switchsync controllers is proposed as proper method.

This paper also investigates lightning overvoltages in the overhead-cable transition. Simulations are performed in PSCAD/EMTDC. Surge arresters are applied in both ends of cable to fulfill the insulation coordination. The maximum amplitude of overvoltages inside the cable is surveyed which should be of great concerns in insulation coordination studies.

**Keywords**—Switching Overvoltage, Lightning Overvoltage, Insulation Coordination, ATP, PSCAD/EMTDC.

## I. INTRODUCTION

THE level of transient overvoltage has a strong effect to power system reliability. It has already been known that switching overvoltages are the most important criteria which the design of insulation of extra high voltage (EHV) systems is based on [1].

With the increment of the operating voltage of transmission systems, switching surge overvoltages determine the insulation design rather than lightning overvoltages. The insulation level required to withstand the switching surge overvoltages can have a significant influence on the cost of transmission systems. Therefore, an accurate estimation of the switching overvoltages under various conditions of operation is an important factor for the design of transmission systems. The main operations that can produce switching overvoltages are line energization and reenergization, capacitor and reactor switching, occurrences of faults and breaker openings [2].

Transmission line switching transient and its severity depend on the difference between the supply and the line voltages at the instant of energization. If energization occurs

at an instant when the difference between supply voltage and the line voltage is high, a large traveling wave would be injected on the transmission line. At the time, this wave reaches the open far end of the line, it gets reflected and a high transient overvoltage is experienced [3].

Such switching transients are of concern for many EHV transmission networks, especially for long transmission lines. For transmission networks rated at voltages of 420 kV and above, switching impulse withstand voltage of the system and its equipments is about 2-3 p.u. and therefore, switching overvoltages have to be kept under control [3], [4].

Line parameters surveyed here are the length of transmission line, trapped charge and shunt compensation. Circuit breaker parameters are pole discordance, preinsertion resistors and their being in system duration. The limitation of the switching overvoltages – especially when used in combination with surge arresters – could be similar to what is achieved with preinsertion resistors [4].

ATP program is used to simulate the energization of a typical 400 kV transmission line. J.Marti Model applied for the transmission line is a frequency dependant model with constant transformation matrix [5]. Since switching phenomenon is simulated; the appropriate matrix frequency is 5 kHz [6].

Lightning overvoltages must be taken into account when designing the insulation system of a cable. The required lightning impulse voltage withstand capability (BIL) is defined in norms (e.g., IEC 60071-2) as specified levels of a 1.2/50  $\mu$ s impulse voltage. IEC specifies one, two, or three BIL levels for each system voltage, thus giving the customer some room for adapting the BIL to the actual lightning overvoltage conditions. The manufacturer is simply required to produce cables that satisfy the lightning test voltages [7].

To avoid cable failures due to Lightning Overvoltages, it is essential to keep the protective level provided by arresters within a safe margin. It is then desirable to calculate the maximum overvoltages experienced by cables with certain accuracy [8].

The models for overhead lines and underground cables in ATP/EMTP are generally based on the Method of Characteristics (MoC) with recursive convolution due to the high efficiency of the resulting model. For overhead lines, satisfactory results can usually be achieved by assuming a constant transformation matrix and frequency-dependent modes. For underground cables, however, the assumption of a constant can lead to erroneous results. This problem can, for most cable systems, be overcome by frequency dependent

A. Hayati Soloot is with Electrical Engineering Department, Iran University of Science and Technology (corresponding author to provide phone: +98-9126508944; e-mail: amir.hayati@gmail.com).

A. Gholami is with Electrical Engineering Department, Iran University of Science and Technology, (e-mail: gholami@iust.ac.ir).

E. Agheb is with School of Electrical and Computer Department, University of Tehran (e-mail: e.agheb@gmail.com).

A. Ghorbandaeipour is with School of Electrical and Computer Department, University of Tehran (e-mail: ali.ghr@gmail.com)

P. Mokhtari is with North Industrial Electricity Company (e-mail: pozghan@gmail.com).

transformation matrix [9], [10].

II. SWITCHING OVERVOLTAGES

A. Simulation Specifications for Line Energization

In order to investigate the effects of power system parameters on switching overvoltages, the following circuit in Fig. 1 is used for simulation. The parameters of the voltage source are determined in Table I.

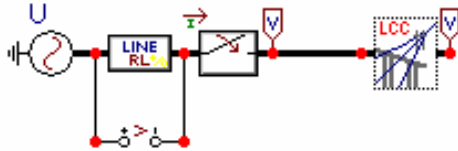

Fig. 1 Power network arrangement applied for simulation in ATP

TABLE I  
PARAMETERS OF THE VOLTAGE SOURCE

source voltage (line voltage)	400 kV
frequency	50 Hz
positive sequence resistance	0.711 Ω
zero sequence resistance	0.55 Ω
positive sequence inductance	11.857 mH
zero sequence inductance	8.98 mH

Fig. 2 depicts the dimensions of the transmission line towers and the conductor arrangements. J. Marti model is defined for transmission line modeling. Skin effect, segmented grounding and transposition are considered in the modeling. Table II provides the radii and resistances of phase conductors and shield wires.

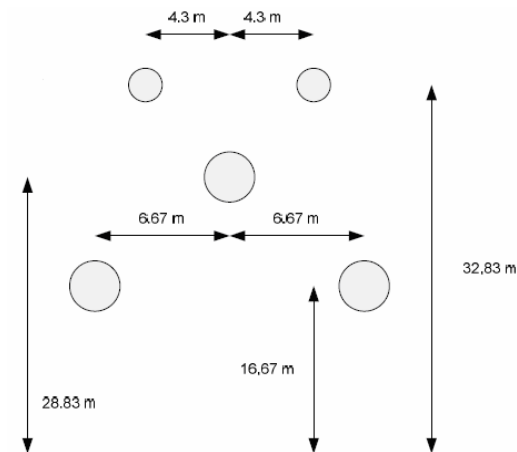

Fig. 2 Conductor arrangements for the 400 kV tower

TABLE II  
RADI AND RESISTANCES OF PHASE CONDUCTOR AND SHIELD WIRE

outer radius of shield wire	0.76 mm
inner radius of shield wire	0
resistance per kilometer of shield wire	1.63 Ω
outer radius of phase conductor	3.15 mm
inner radius of phase conductor	0.85 mm
resistance per kilometer of phase conductor	0.033 Ω

Considering these phase distances, the per-meter inductance and per-meter capacitance of transmission line is achievable by these formulas [11]:

$$L = \frac{\mu_0}{2\pi} \ln\left(\frac{GMD}{r'}\right) \quad (\text{H/m}) \quad (1)$$

$$C = \frac{2\pi\epsilon_0}{\ln\left(\frac{GMD}{r}\right)} \quad (\text{F/m}) \quad (2)$$

where:

$$GMD = \sqrt[3]{D_{12}D_{13}D_{23}} \quad (3)$$

$$r' = r \times e^{-0.25} \quad (4)$$

$D_{12}$ ,  $D_{13}$  and  $D_{23}$  in equation (3), are phase-to-phase distances and  $r$  is the radius of phase conductor. The time takes for switching surge to travel from the beginning to the end of the transmission line is represented by  $\tau$  and is calculated using equation (5):

$$\tau = l\sqrt{LC} \quad (5)$$

In equation (5),  $l$  is the length of the transmission line and is assumed 220 kilometer in this paper. For the dimensions shown in Fig. 2 and the assumed length,  $\tau$  is 0.74 millisecond. The period of switching overvoltages is  $4\tau$  and equals to 2.96 millisecond.

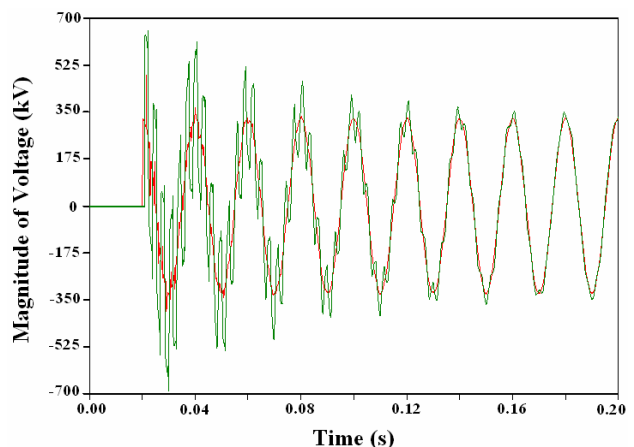

Fig. 3 Voltage at the beginning of the transmission line (red curve), voltage at the end of the transmission line (green curve)

The duplication of the switching surge at the end of transmission line is illustrated in Fig. 3 and Fig. 4. From Fig. 3, it can be obtained that damping of switching overvoltages takes around 100 milliseconds. Comparing the green curve (voltage at the end of transmission line) with the red one (voltage at the beginning of transmission line) in Fig. 4, traveling time is 740 microseconds which exactly corresponds to the amount calculated from equation 5.

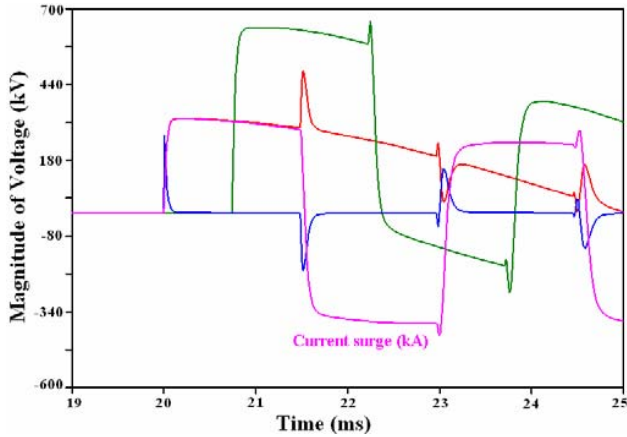

Fig. 4 Voltage at the beginning of the transmission line (red curve), voltage at the end of the transmission line (green curve), voltage drop on the equivalent short circuit impedance (blue curve) and current surge by a factor of 500 (pink curve)

It takes  $2\tau$  for switching surge to return to the beginning of the transmission line. In this time interval, voltage and current surges have the same form, just the current surge is 500 times smaller than voltage one. This multiplication factor is equal to surge impedance  $Z_s$  which is defined as:

$$Z_s = \sqrt{\frac{L}{C}} \quad (6)$$

The diversion of current surge after  $2\tau$  causes a spike voltage on the equivalent short circuit impedance and affects the switching surge as well. According to what mentioned in this section, the effect of power system parameters is investigated in the following sections.

### B. Effect of Voltage Source Parameters

Voltage source represents network voltage, frequency and short circuit impedance. Among these parameters, network voltage and frequency are consistent and short circuit impedance can be considered as a variable parameter.

At first, the effect of positive sequence inductance is surveyed. If the positive sequence inductance is multiplied by four, the time constant of voltage rising at the end of the transmission line will be quadrupled. It results in smoother switching overvoltage but the peak of switching transient is some ten kilovolts higher. In order to describe this effect, the following equations just after switching can be applied:

$$U = Ri + L \frac{di}{dt} + U_f \quad (7)$$

$$U_f = Z_s i_f \quad (8)$$

$R$  and  $L$  in equation 7 and 8 are  $R_+$  and  $L_+$ .  $U_f$  is the front traveling surge. Combining the two equations, equation (9) is resulted.

$$U_{RL} = \frac{RU}{R + Z_s} + \frac{Z_s U}{R + Z_s} e^{-\frac{(R+Z_s)t}{L}} \quad (9)$$

$U_{RL}$  is the voltage drop on equivalent short circuit impedance. As  $R$  is so smaller than  $Z_s$ , equation 9 can be simplified to the following formula:

$$U_{RL} = U e^{-\frac{Z_s t}{L}} \quad (10)$$

Equation 10 describes the blue curve in Fig. 5. Increasing the inductance leads to higher time constant for the deduction of voltage on short circuit impedance and consequently slower increase in switching surge at the beginning and end of transmission line.

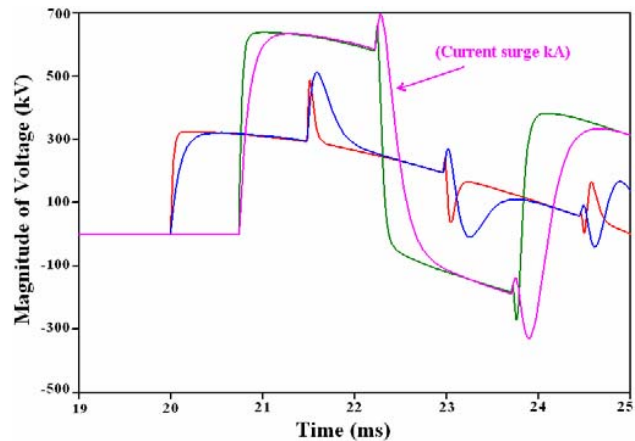

Fig. 5 Voltage at the beginning (red curve) and voltage at the end of the transmission line (green curve) for  $L_+ = 1.857$  mH, voltage at the beginning of the transmission line (blue curve) and voltage at the end of the transmission line (pink curve) for  $L_+ = 47.4$  mH

### C. Effect of Circuit Breaker Parameters

Circuit breaker plays the main role in transient overvoltages of line energization. Voltage difference on circuit breaker before switching definitely determines the amplitude of overvoltages at the end of transmission line.

In previous section, it was mentioned that energizing a transmission line at the moment of peak voltage results in 2 p.u. overvoltage surge at the end of transmission line. In order to reduce the amplitude of overvoltages, pre-insertion resistors can be used at the moment of switching.

The simulation circuit suitable for investigating pre-insertion resistor effect is brought in Fig. 6. The time interval which the resistor presents is in the order of milliseconds due to the mechanical delay time in breakers which is in the same order. The second breaker bypasses the resistor after some ten milliseconds of first breaker closure. This delay time is a margin to prevent from closure of bypassing breaker sooner

than main breaker.

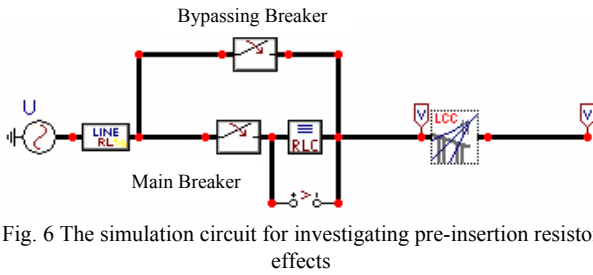

Fig. 6 The simulation circuit for investigating pre-insertion resistor effects

Fig. 7 describes the effect of pre-insertion resistance value on the amplitude of overvoltages in the 400 kV network in Fig. 6. Increasing the resistance, the amplitude of overvoltages will be deducted. Besides, the more resistance is inserted, the more voltage drop is across the pre-insertion resistor in steady state which means that if the bypassing of the resistor is not done precisely at the moment of zero potential across it, higher switching transients will occur again. This effect was of main importance when the idea of synchronous switching was not prompt. Synchronous switching by switch-sync relays is definitely a proper substitution for pre-insertion resistors which will be discussed in next section.

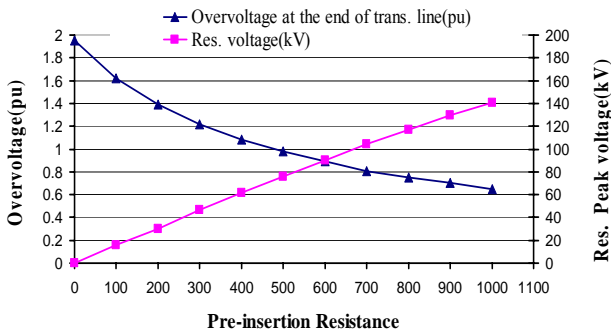

Fig. 7 The effect of pre-insertion resistance on overvoltage amplitude and voltage on pre-insertion resistor in steady state

Analyzing the curves in Fig. 7, the optimum pre-insertion resistor is 500 ohm which is equal to surge impedance of transmission line. In this case, pre-insertion resistor is called matching impedance. This matching impedance makes the switching surge to be half in the beginning of the transmission line and at the end it will be doubled. So, the amplitude will be the same as original switching surge and not more.

As in Table III, the more resistance, the sooner the overvoltage transients damp which result in the decrement of insulation failure probability. It confirms that 500 ohm is the appropriate value for pre-insertion resistance.

*D. Effect of Transmission Line Parameters*

For a transmission line with definite length and definite tower geometry, the main and effective parameter which should be considered is the trapped charge on transmission line. To model the effect of trapped charge, the follow circuit is applied, Fig. 8.

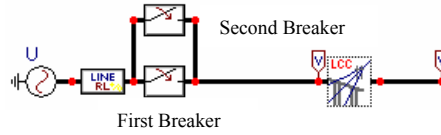

Fig. 8 The simulation circuit to model the trapped charge

TABLE III  
DAMPING TIME OF OVERVOLTAGE TRANSIENTS APPLYING VARIOUS RESISTANCE VALUES

Resistance Value (Ohm)	Damping Time (ms)
0	140
100	20
200	10
300	10
400	2
500	0

The worst case is when a trapped charge of -1 p.u and energizing the transmission line in +1 p.u. The transient overvoltage reaches to 3 p.u. illustrated in Fig. 9. The insulators at the end of transmission line encounter 4 p.u. voltage changes in 100 us when the first surge reaches to end of transmission line.

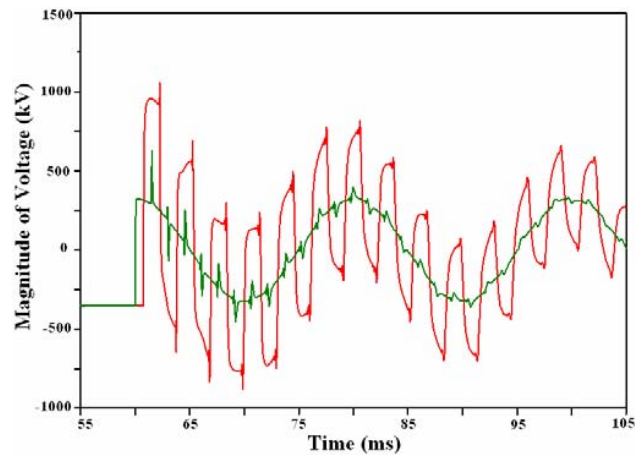

Fig. 9 Switching surge in the beginning (green curve) and at the end of transmission line (red curve), the transmission line has -1 p.u. trapped charge and line energized in 1 p.u.

Energizing the line at the moment of zero voltage while line has -1 p.u. trapped charge has two forms, Fig. 10 and Fig. 11. First surge has more severe waveform in the case when voltage ascends after voltage zero, Fig. 10. The maximum overvoltage in both cases is 2.5 p.u. The last case which can be obtained by synchronous switching has the lowest overvoltages in the order of 1.5 p.u., Fig. 12. Thus, energizing the transmission line considering the equipotentiality of breaker terminals deduces the overvoltages to the acceptable margin.

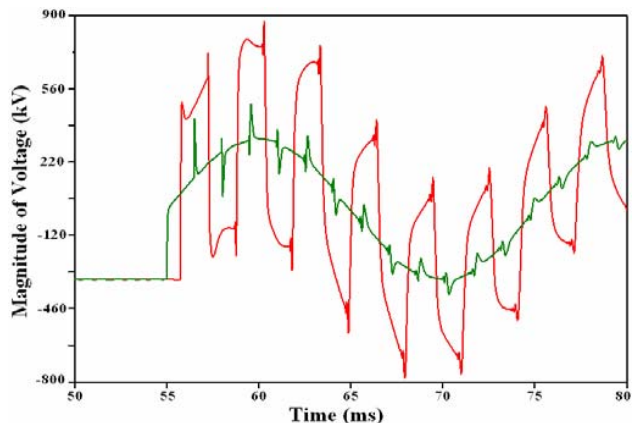

Fig. 10 The switching surge in the beginning (green curve) and at the end of transmission line (red curve), the transmission line has -1 p.u. trapped charge and line energized at the moment of zero potential and when the sinusoidal voltage curve goes up to 1 p.u.

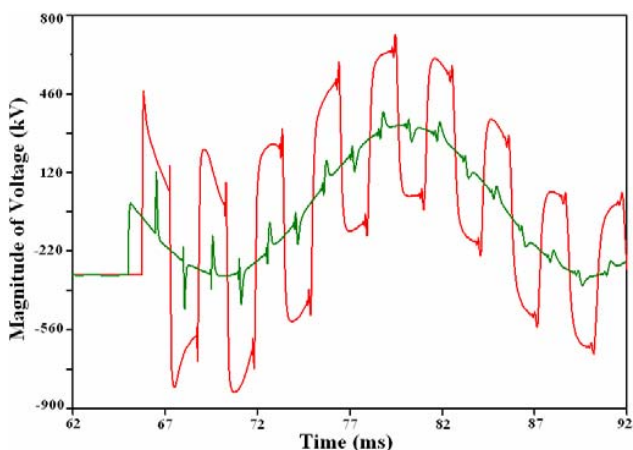

Fig. 11 The switching surge in the beginning (green curve) and at the end of transmission line (red curve), the transmission line has -1 p.u. trapped charge and line energized at the moment of zero potential and when the sinusoidal voltage curve goes down to -1 p.u.

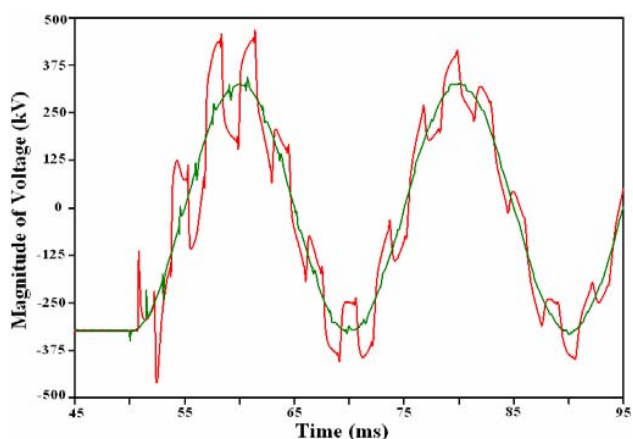

Fig. 12 The switching surge in the beginning (green curve) and at the end of transmission line (red curve), the transmission line has -1 p.u. trapped charge and line energized at -1 p.u.

### III. LIGHTNING OVERVOLTAGES

#### A. Lightning Modeling

Sometimes, there is a necessity to connect over-head lines with cable systems. It mostly occurs in distribution networks. In special cases such as environmental requirements or limited space for overhead lines in densely populated areas, the usage of cable connection or GIL [12] is mandatory.

As the overhead line and cable connection illustrated in Fig. 13, lightning may strike one phase of the overhead line and the overvoltage surge travels toward the cable. A surge arrester should be applied in the connection point to protect cable from overvoltages. By the way, simulations should be performed to notice about the possibility of the maximum overvoltage occurrence inside the cable and its amplitude.

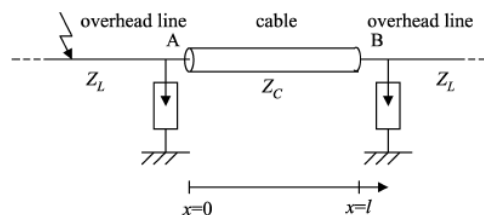

Fig. 13 Overhead line- Underground transition [7]

A 100 kilometers transmission line, which has cable transition in the 50 kilometer, is simulated in this paper, Fig 14. The transmission line has 132 kV rated line voltage and feeds a load of 50 MW, 50 MVAR at the end of the transmission line. The characteristics of the voltage source are brought in Table I.

TABLE IV  
PARAMETERS OF THE VOLTAGE SOURCE

source voltage (line voltage)	132 kV
frequency	50 Hz
positive sequence resistance	0.711 Ω
positive sequence inductance	11.857 mH

Fig. 15 depicts the dimensions of the transmission line towers and the conductor arrangements.  $C_1$  is a side conductor and considered as phase A. As illustrated in simulation circuit, Fig. 14, the lightning surge strikes  $C_1$ .

The specifications of the phase conductor and shield wire are given in Table II.

TABLE V  
THE SPECIFICATIONS OF PHASE CONDUCTOR AND SHIELD WIRE

phase conductor radius	0.02m
phase conductor DC resistance	0.032 ohms/km
SAG for all conductors	10m
ground wire radius	0.0055m
Ground wire DC resistance	2.865ohms/km
SAG for all ground wires	10m
Shunt conductance	1e-11 mhos/m



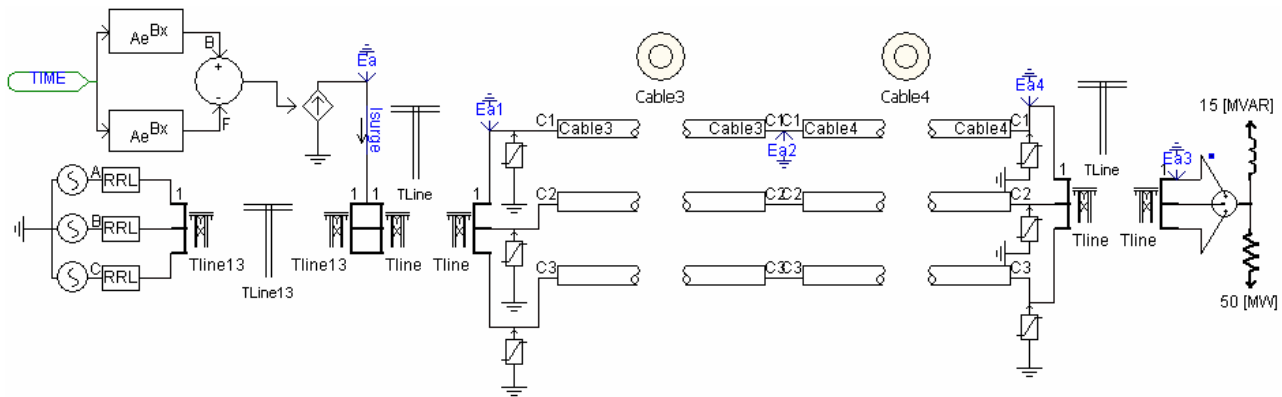

Fig. 14 The simulation circuit of the 100 kilometer transmission line with cable transition in middle.

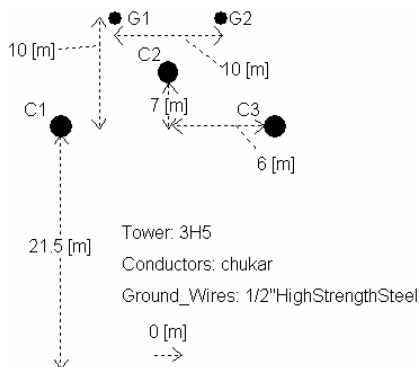

Fig. 15 Conductor arrangement of the transmission tower

In PSCAD/EMTDC a frequency dependent phase model is applied for the transmission line and the underground cable. In this model, curve fitting start frequency is 0.5 Hz and curve fitting end frequency is 1 MHz. Maximum order of fitting for both  $Y_{shunt}$  and propagation function is 20 with the maximum fitting error of 0.2%.

The radius of different layers of underground cable is illustrated in Fig. 16. The underground cable is placed 1meter under the ground surface.

In this model, lightning surge is modeled with a current source with the following equation:

$$I = I_m (e^{-at} - e^{-bt}) \tag{9}$$

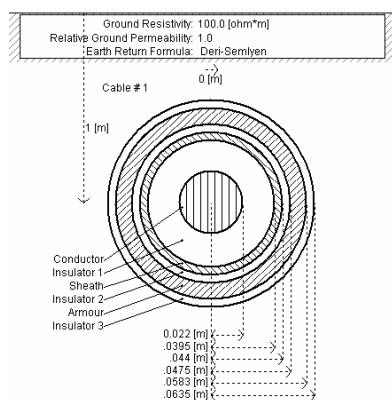

Fig. 16 Underground Cable Characteristics

In order to obtain 1.2/50  $\mu$ s lightning surge in PSCAD/EMTDC, parameter  $a$  in equation (9) is adjusted to 15500, in which the half time will be set to 50  $\mu$ s. Parameter  $b$  is 2500000. So, the rise time is 1.2  $\mu$ s, the blue curve in Fig. 17.

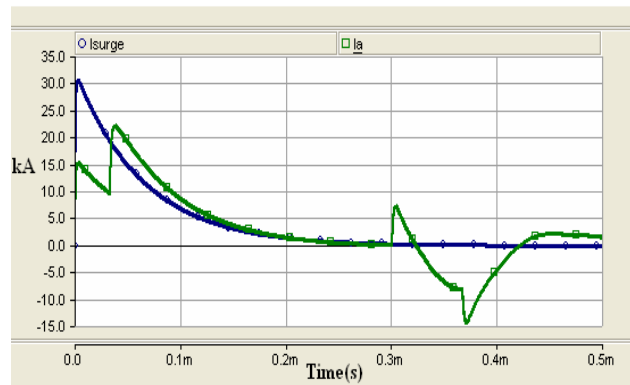

Fig. 17 Current waveform of lightning surge,  $I_{surge}$  (blue curve), current of the point hit by lightning in phase A,  $I_a$  (green curve)

Analyzing the green curve and comparing it with the blue one, the addition of another surge to flowing lightning surge in phase A is obtainable. It emerges some ten microseconds after lightning surge injection. The time interval is around twice the time takes for surge to reach to cable connection. Therefore the time interval directly depends on the distance of stroke place to cable connection. After some 100 microseconds, another pulse can be observed in current waveform of stroke point. In fact, that's the reflection of lightning surge reached to the source.

### B. Simulation Results

In the model delivered in Fig. 14, the overvoltage at the end of the second section of the transmission line and cable end is directly related to lightning current and distance of lightning strike from the cable.

In Fig. 18, the overvoltage surges at different places along the transmission line are illustrated. It should be noted that the

waveforms of  $V_{cable}$  and  $V_{load}$  are multiplied by a scale factor of 10 in order to be in the same order of magnitude with  $V_{surge}$ . Thus, the maximum surge amplitude on the load is limited to 2.5 p.u. For stroke place, a sharp deduction in voltage surge after some ten microseconds is observable. Simulating precisely the time interval which this phenomenon happened, the reflection of lightning surge from cable-transmission line connection can be comprehended as the cause for it. The moment which the reflected surge reaches the stroke point, the duplication in current surge and sharp decrease in voltage surge come about simultaneously, Fig. 19. Since the surge impedance of cable is one order of magnitude lower than that of transmission line and the overvoltage surge reflects again at the end of cable, the sharp decrease follows by a smooth increase in the voltage at the stroke point. For cables with longer length, the reflections inside cable are more obvious, Fig. 18 and Fig. 19.

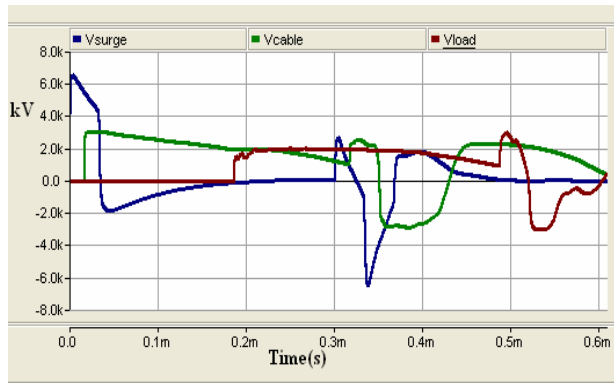

Fig. 18  $V_{surge}$ : Voltage surges in the stroke place (blue curve),  $V_{cable}$ : Voltage surge at the beginning of cable (green curve) and  $V_{load}$ : Voltage surge on the load (red curve) for Lightning strike with amplitude of 30 kA and 5 km distance from the cable.  $V_{cable}$  and  $V_{load}$  are multiplied by 10

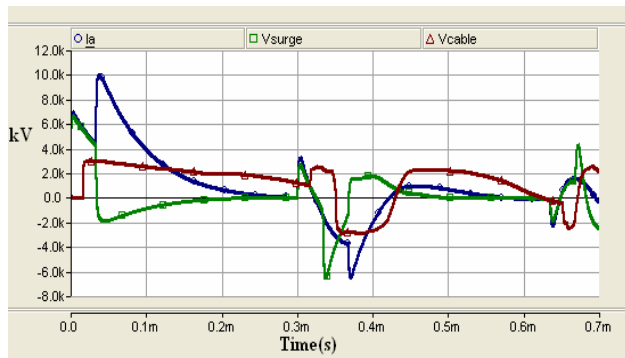

Fig. 19  $I_a$ : current of the point hit by lightning in phase A (blue curve),  $V_{surge}$ : Voltage surges in the stroke place (green curve),  $V_{cable}$ : Voltage surge at the beginning of cable (red curve) for Lightning strike with amplitude of 30 kA and 5 km distance from the cable.  $I_a$  is multiplied by 450 and  $V_{cable}$  is multiplied by 10

voltage surge on the load without or with applying surge arrester, respectively. Comparing these figures, one can obtain that the amplitude of overvoltages are deducted one order of magnitude and limited to 2 p.u. which is bearable for line insulators and load dielectrics. Although the application of surge arrester ensures insulation coordination for load and line insulators, the overvoltages inside cable and their severity should be seriously considered.

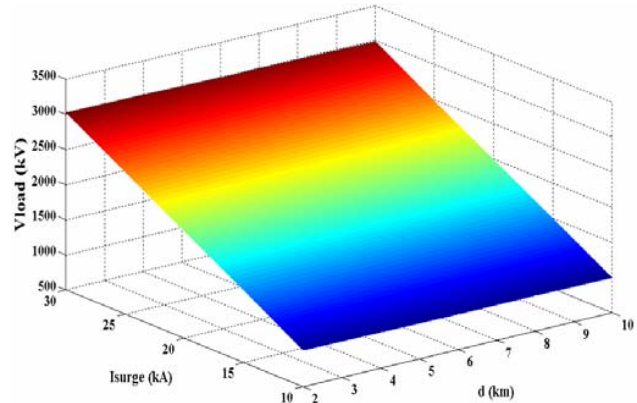

Fig. 20 Maximum amplitude of voltage surge on the load without cable surge arresters in cable-line connection

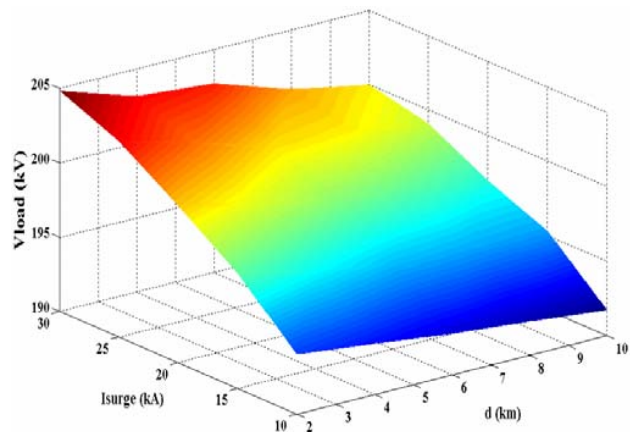

Fig. 21 Maximum amplitude of voltage surge on the load with cable surge arresters in cable-line connection

Fig. 22 and Fig. 23 depict the voltage surge at different points inside the cable while the lightning strike the line at 2km and 25 km to cable connection, respectively. The first voltage surge approaches 4 p.u. and even more instantaneously and have oscillatory waveform. The longer distance lightning strikes the transmission line, the closer are the first surge and the reflected surge from voltage source. Thus, overvoltage surge inside cable will be similar to square form with some oscillations, Fig. 23.

Fig. 20 and Fig. 21 depict the maximum amplitude of

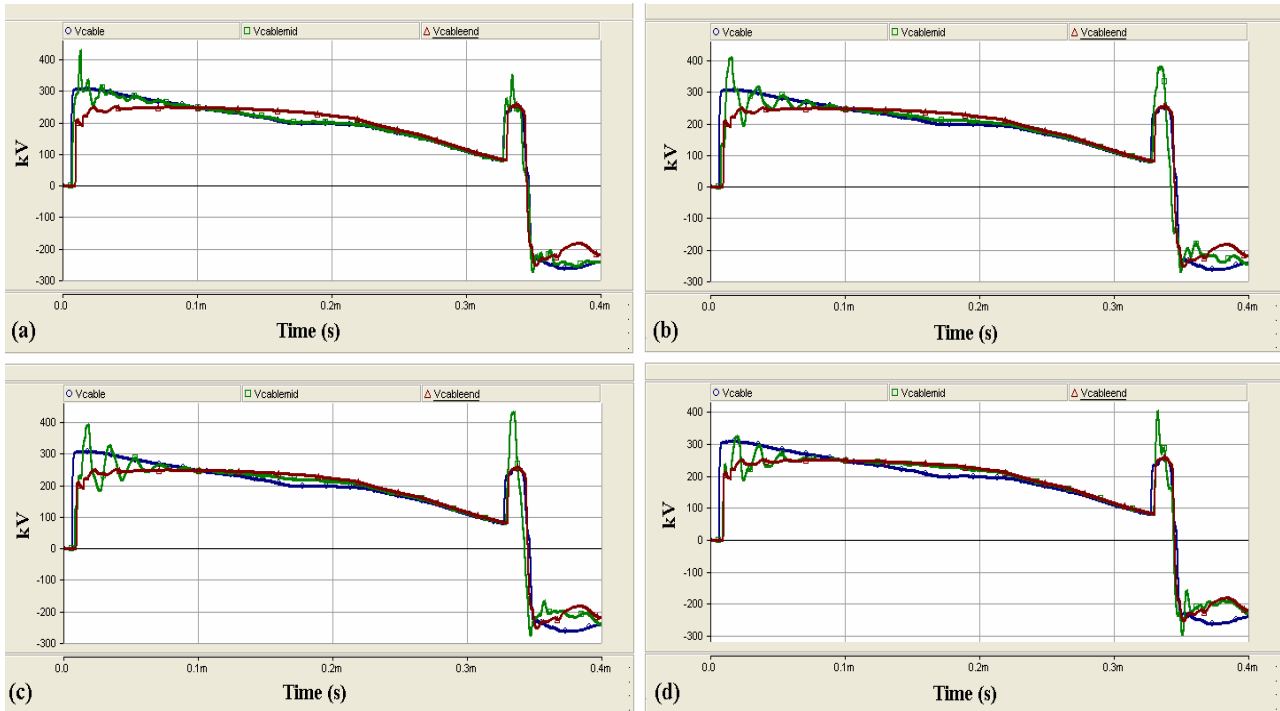

Fig. 22  $V_{\text{cable}}$ : Voltage surge at the beginning of cable (blue curve),  $V_{\text{cableend}}$ : Voltage surge at the end of cable (red curve),  $V_{\text{cablemid}}$  (green curve): Voltage surge inside cable at 50 m from cable beginning (a), 150 m from cable beginning (b), 250 m from cable beginning (c) and 350 m from cable beginning (d). The cable length is 420 meters. Lightning surge strikes the line at 2 kilometers to cable and its amplitude is 30 kA.

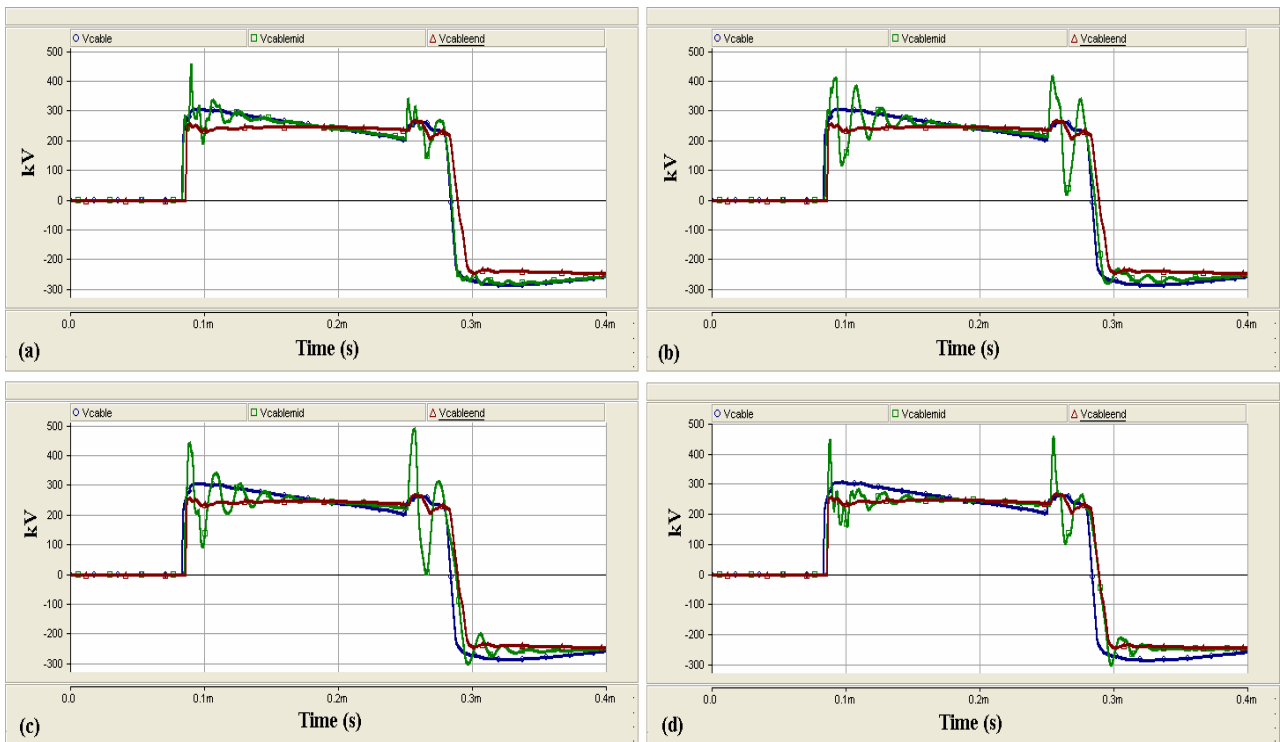

Fig. 23  $V_{\text{cable}}$ : Voltage surge at the beginning of cable (blue curve),  $V_{\text{cableend}}$ : Voltage surge at the end of cable (red curve),  $V_{\text{cablemid}}$  (green curve): Voltage surge inside cable at 50 m from cable beginning (a), 150 m from cable beginning (b), 250 m from cable beginning (c) and 350 m from cable beginning (d). The cable length is 420 meters. Lightning surge strikes the line at 25 kilometers to cable and its amplitude is 30 kA.



## IV. LIGHTNING OVERVOLTAGES

Investigating switching overvoltages due to line energization, network short circuit impedance, pre-insertion resistors and the trapped charge of transmission line have the main effect on switching transients. The optimum pre-insertion resistor obtained from simulation results, is called matching impedance which is equal to surge impedance of transmission line. The hazardous transients caused by energizing transmission line while line has opposite trapped charge presents the necessity of closing the breaker when its terminal is equipotential. The implementation of switch sync relays properly deduces the transient overvoltages.

Investigating lightning overvoltages in overhead-underground transition, the effective application of surge arrester with  $V_{ref}$  120 kV is simulated in a 100 km 132 kV transmission line. The implementation of arresters in cable-line transition points result in the one order of magnitude reduction of overvoltages comparing to having no arresters. The overvoltages restricted to 2 p.u. which is bearable for line insulators and load dielectrics. Although insulation coordination is fulfilled for transmission line and load by surge arresters, the overvoltages inside cable and their severity should be seriously considered which may approach 4. p.u. and even more instantaneously and have oscillatory waveform.

## REFERENCES

- [1] K. Ngamsanroaj and W. Tayati, "An analysis of switching overvoltages in the EGAT 500 kV transmission system", in proc. 2003 IEEE Conference on Power Engineering, pp. 149-153.
- [2] A. I. Ibrahim and H. W. Dommel, "A Knowledge Base for Switching Surge Transients", in proc. Intr. Conf. on Power Systems Transients (IPST'05), Montreal, Canada, 2005, paper 50.
- [3] M. Sanaye-Pasand, M.R. Dadashzadeh and M. Khodayar, "Limitation of transmission line switching overvoltages using switchsync relays", in proc. Intr. Conf. on Power Systems Transients (IPST'05), Montreal, Canada, 2005, paper 87.
- [4] "Controlled Switching Application Guide", Edition 1, ABB., 2004.
- [5] B. Gustavsen and A. Semlyen, "Calculation Of Transmission Line Transients Using Polar Decomposition", IEEE Trans. on Power Delivery, vol. 13, pp. 855-862, July 1998.
- [6] P.C. Magnusson, "Traveling Waves on Multi-Conductor Open-Wire Lines-A Numerical Survey of the Effects of Frequency Dependence of Modal Composition", IEEE Trans. on Power Apparatus and systems, PAS-92, pp. 999-1008, May 1973.
- [7] T. Henriksen, B. Gustavsen, G. Balog, and U. Baur, "Maximum Lightning Overvoltage along a Cable Protected by Surge Arresters", IEEE Trans. Power Delivery, vol. 20, pp. 859-866, April 2005.
- [8] J. A. Martinez and F. Gonzalez-Molina, "Surge protection of underground distribution cables", IEEE Trans. Power Delivery, vol. 15, pp. 756-763, April 2000.
- [9] B. Gustavsen and J. Mahseredjian, "Simulation of Internal Overvoltages on Transmission Lines by an Extended Method of Characteristics Approach", IEEE Trans. Power Delivery, vol. 22, pp. 1736-1742, July 2007.
- [10] B. Gustavsen and A. Semlyen, "Simulation of transmission line Transients using vector fitting and modal decomposition", IEEE Trans. Power Delivery, vol. 13, pp. 605-614, April 1998.
- [11] H. Saadat, Power System Analysis, McGraw-Hill, 1999, pp. 112-127.
- [12] H.Koch and T.Hillers, "Second generation gas-insulated line", IEEE Power Engineering Journal, vol.16, pp 111-116, Jun 2002.