

# Hybrid Fuzzy Selecting-Control-by-Range Controllers of a Servopneumatic Fatigue System

Marco Soares dos Santos, Jorge Augusto Ferreira, Camila Nicola Boeri and Fernando Neto da Silva

**Abstract**—The present paper proposes high performance non-linear force controllers for a servopneumatic real-time fatigue test machine. A CompactRIO<sup>®</sup> controller was used, being fully programmed using LabVIEW language. Fuzzy logic control algorithms were evaluated to tune the integral and derivative components in the development of hybrid controllers, namely a FLC P and a hybrid FLC PID real-time-based controllers. Their behaviours were described by using state diagrams. The main contribution is to ensure a smooth transition between control states, avoiding discrete transitions in controller outputs. Steady-state errors lower than 1.5 N were reached, without retuning the controllers. Good results were also obtained for sinusoidal tracking tasks from  $1/\pi$  to  $8/\pi$  Hz.

**Keywords**—Hybrid Fuzzy Selecting, Control, Range Controllers, Servopneumatic Fatigue System.

## I. INTRODUCTION

ALTHOUGH pneumatic control systems have relatively small size, light weight, high speed and can be used without explosion danger, tracking operations with a high accuracy remains its major problem. These systems also present a high power-to-weight, low cost and do not work with a pollutant fluid, but their performance is a much discussed matter by researchers all over the world. The fast technological evolution in this domain during the last few years has allowed the development of complex control techniques. Their evolution is strongly linked to control techniques' evolution [1]. Air compressibility, piston friction, pressure losses and nonlinear behavior of servovalves are the main problems of this kind of actuation. Because of their highly nonlinear characteristics, classical control theory is unable to provide the same good results as the *well behaved* systems, such as electrical devices [2]. Advanced control strategies can be used to obtain good spool dynamic characteristics over the whole valve operating conditions in order to overcome its highly non-linear operation [3]. Carneiro [4] underlines the scientific research dynamism of pneumatic system control.

Servopneumatic systems play a significant role in industrial

automation, mainly in manufacturing and distribution systems, but they can also be found in applications for biomedicine and biomechanical research projects, pneumatic step-by-step motors, McKibben muscles, pneumatic rubber actuators [5], braided pneumatic actuators [6], biomimetic robotic devices [7], human-support robots, invasive surgery systems or micro-robots used for colonoscopies, etc.

Richer and Hurmuzlu [8] proposed two nonlinear sliding mode force controllers: the first one is a *complete*-based controller because uses a *complete* pneumatic system model; the second one is a *reduced*-based controller because it is applied a reduced order model that disregards mainly the valve dynamics and the time delay due to connecting tubes. Requiring a very complex online computation for the control law, the *complete*-based controller have always achieved better performances than the *reduced*-based controller, although the slightly reduced performances appeared in configurations with relatively short tubes and at frequencies up to 25 Hz. Applying sinusoidal trajectory tracking tasks, good performance up to 20 Hz and very good results up to 5 Hz were achieved. The steady-state errors' analysis was not taken into account. Xiang and Wikander [9] also use information from mathematical models and proposed a solution based on nonlinear feedback linearization methodology to deal with the nonlinearities. They split the pneumatic system model into several modules (dynamic of the chambers' pressure, friction, servovalves, etc) and acted upon each of them with a linearization function. The nonlinear feedback controller was then applied to the reduced order linearized-based module. The controlled system was tested only with a force tracking reference, where seems to be achieved good tracking performances. Numerical tracking errors were not quantified, including steady-state errors, and a performance analysis was not pointed up. The mathematical model inaccuracy remains a hard difficulty that needs to be overcome. In fact, control algorithms designs assuming "perfect" models is an expensive mistake, because all the conclusions are as accurate as the model that they were developed from. However, very complex mathematical models require control algorithm's very complex online computation. Because it is not feasible to uncover all possible physical process's dynamics, researchers have not reached a conclusion about if apply their approaches with numerical-based models, experienced-based models, a hybrid solution of both, or another one [10]. There is a relation between the control system performance and the mathematical model

This work was supported by FCT - Foundation for Science and Technology, under the PTDC/EME-PME/70824/2006 project.

M. Soares dos Santos, J. A. F. Ferreira, C. N. Boeri and F. J. Neto da Silva are with the Department of Mechanical Engineering of University of Aveiro, Aveiro (corresponding authors to phone: (+351) 234370830; fax: (+351)234370953; e-mail: marco.santos@ua.pt, jaff@ua.pt, camilaboeri@ua.pt, fneto@ua.pt).

accuracy, which implies the requirement of lower-order *design models* by several nonlinear techniques [11]-[13]. To overcome this problems, Liu, Lee and Li [14] designed a MISO-based FLC hybrid controller (PID+FLC), but a discrete switch is used to choose which controller is turned on. The fuzzy controller was parameterized with twenty-two fuzzy sets and fifty-six rules. They refer steady-state errors close to zero, but a numerical performance analysis was not taken into account. Only presenting the experimental results concerning the tracking test of a squared trajectory, they concluded that the hybrid fuzzy PID controller is suited or high-precision control of pressure in a pneumatic chamber. Kaitwanidvilai and Parnichkun [15] research a solution based on hybrid adaptive neuro-fuzzy model reference controller (ANFMRC). Although the steady-state errors were not pointed up, they compared a conventional and a hybrid ANFMRC through a squared tracking reference with amplitudes lower than 10 N. Although a numeric performance analysis is missing, graphically is possible to conclude about the better performance of the hybrid ANFMRC controller over the conventional one, especially at the initial period. Ying, Jiafan, Can-jun and Bin [16] developed a hybrid controller that performs a multi-mode switch between a bang-bang control and a FLC. Through twenty-nine fuzzy sets and seventy-seven rules, the FLC was built under heuristic information. Step, slope and sinusoidal tracking references were used to analyze its performance: the system showed a good performance and a good agreement between experimental and simulated responses as well. The steady-state errors were not numerically quantified. Ruihua, Weixiang e Qingyu [17] applied a single MISO-based multi-region FLC with three inputs (error, error change and an auxiliary variable). Twenty fuzzy sets and seventy-five rules were proposed to control squeezing forces between 8 and 50 kN. Only maximum absolute errors lower than 2 kN were confirmed.

This work is mainly related to products or projects whose aims were the development of new methods for fixation of biomechanical devices to biological tissues; new materials, more resistant to fatigue failure and breakage than conventional ones; new concepts in design of prosthesis; new studies about biomechanical systems of articulation and clinical phenomena which frequently happen in patients having arthroplasty. This background has drawn the need to develop a high performance force control for a one-degree-of-freedom servo-pneumatic machine, which was developed by Biomechanics Research Group of the University of Aveiro to carry out fatigue simulation tests on biomechanical devices. Because through fuzzy sets and rules it is possible to model any nonlinear function as far as the desired accuracy [18] and perform any nonlinear control action [19], two fuzzy logic controllers are proposed: a SISO-based FLC P controller and a MISO hybrid soft Real-Time-based and Selecting-Control-by-Range FLC PID controller. The second one takes into account a nonlinear contribution of the integral and derivative's errors, assuring smoothness at the switch of the several control states through fuzzy rules. There are a lot of studies involving the comparison between controllers. Much of them are about fuzzy control, but designed according MISO-based configurations, being neglected the potential performance that

can be achieved by SISO-based FLC controllers, namely FLC P's designs.

## II. ELECTROPNEUMATIC SYSTEM

The servopneumatic machine has one degree of freedom and was optimized to simulate the biomechanical behavior of different anatomical models experimentally: complex models as joints (knee, hip) or simpler models as synthetic femurs or tibias, with and without prostheses, making possible the static and dynamic characterization of biomechanical devices, through force tracking tasks.

Figure 1 shows the servopneumatic machine's mechanical apparatus and instrumentation. It is composed for:

- a double effect pneumatic cylinder (Festo CRDNGS 80-200-PPV-A) with a length of 200 mm and a diameter of 80 mm to ensure 3016 N at 6 bar;
- a servo-valve (Festo MPYE-5-1/8-HF-010-B) with a nominal flow rate of 700 l/min;
- an optical linear scale (Fagor SV- B220) measures the cylinder's spool motion with a resolution of 1 μm;
- a load cell (AEP TC4) to measure the applied force to the biomechanical device, with a full scale measurement of 10 kN and a maximum linearity of 0.05% of that value.

## III. HARDWARE PLATFORM

The National Instruments PAC CompactRIO® it's an embedded and data acquisition control system with: a real-time controller to perform autonomous, distributed and high speed deterministic control applications; and a FPGA to perform parallel execution of customized hardware functions. The PAC is composed by a CompactRIO® Intelligent Real-Time Controller NI cRIO-9002, a four-slot reconfigurable embedded chassis NI cRIO-9101, a 16 bit Analog Input NI cRIO-9215, a Digital Input NI cRIO-9411 and a 16 bit Analog Output NI cRIO-9263.

The real-time controller NI cRIO-9002 has its own 195 MHz industrial processor, 32 MB DRAM memory, 64 MB hard memory, a FTP server and the multithread embedded and deterministic processing skill with a 1 kHz clock. It has a soft real-time LabVIEW Real-Time (Phar Lap ETS 10.1 RTOS) operating system (OS). The CompactRIO-9101 is a four slots chassis that provides connection to four I/O modules and includes a FPGA with one million gates connected to I/O modules to allow data acquisition through several I/O functions. The FPGA is a reconfigurable parallel processing hardware device with 40 MHz clock that can be programmed to perform deterministic control and data acquisition operations.

The PC has got an Intel CPU, core (TM) 2, with 2 GHz clock and 2 GB RAM memory.

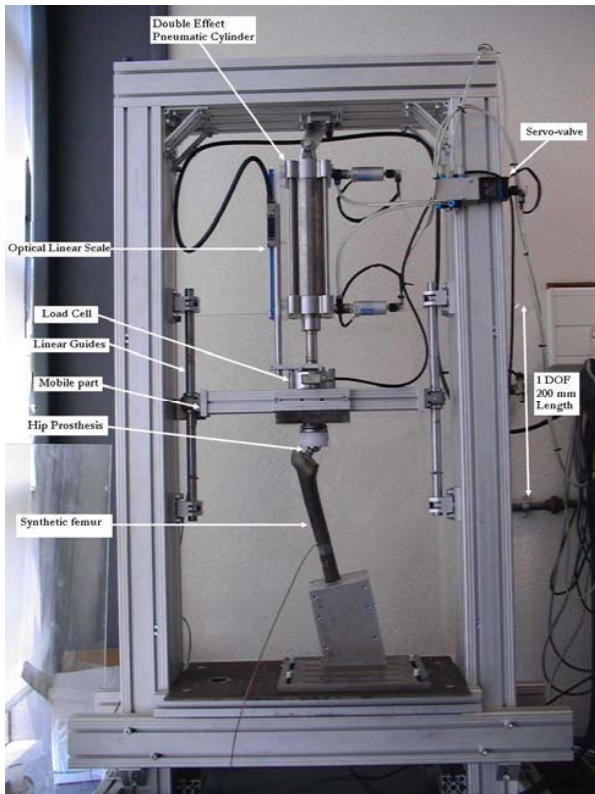

Fig. 1. Servopneumatic machine, with a femur and a hip prosthesis assembled to perform force tracking control references.

#### IV. SOFTWARE PLATFORM

All the control, monitor and data acquisition software were implemented using LabVIEW 8.0 Professional Development System and LabVIEW Reconfigurable Software Development Kit, which includes LabVIEW Real-Time 8.0 and LabVIEW FPGA 8.0 modules.

The built-in software platform ensures the self-rule controller, experiment reliability, easy interface with the user operator, remote web monitoring, easy controllers' upgrade and flexibility to perform different tests [20]. The main problem is the operation scheduling between the several hardware tools and the several software operations. The hardware platform has allowed the development of a three layer distributed software: a PC to boot the cRIO-9002, with the purpose of perform graphical operations; the cRIO-9002 to boot the FPGA, in order to ensure several operations, such as communications, trajectories generation and data storage; the FPGA to perform I/O operations. The operations schedule is a hard problem because deals with the allocation of several communication operations (between the PC and the cRIO-9002, and between cRIO-9002 and the FPGA), control algorithms processing, trajectories generation and data storage with different priorities, periods and deadline, and with no more than a 1 kHz clock available using a soft real-time OS. Using the same methodology, two different configurations were analyzed by Santos *et al* [21], who have also conducted previous work about the design of force controllers.

#### V. CONTROLLERS DESIGN

The “mamdani” inference mechanism, “minimum” implication, “maximum” aggregation and “COG” defuzzification methods were applied to all the proposed FLCs.

FLC algorithm's on-line processing may demand a high computational complexity processing resources. Processing a matrix representation of the parameterized fuzzy model is an easy approach to overcome this problem. The Fuzzy Logic Toolbox's functions from MATLAB<sup>®</sup> provide n-dimensional look-up-tables (LUT) to allow real-time processing. The FLC P and FLC PID outputs are represented by a  $100 \times 1$  and  $100 \times 100$  matrices, respectively. The output value is settled by linear interpolation for input values within these ranges [22], prevailing over the MacVicar-Whelan problem [23].

##### A. FLC P Controller

A SISO FLC P is proposed, applying a nonlinear function (equation 1) to the current error through nine triangular membership functions (MF) for the input error and nine for the output. It was designed to have high sensibility to small errors and neglect error changes. Figure 2 and 3 display the controller's block diagram and control curve, respectively. The parameter optimization was attained through a manual iterative optimization tuning, being found:  $K_{FP} = 1.74$ .

$$F_{FLC\_P}(t) = K_{FP} K_{FLC\_P}(e(t)) \quad (1)$$

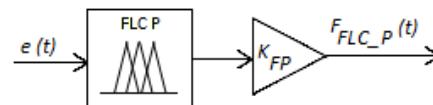

Fig. 2. Block diagram of the FLC P controller.

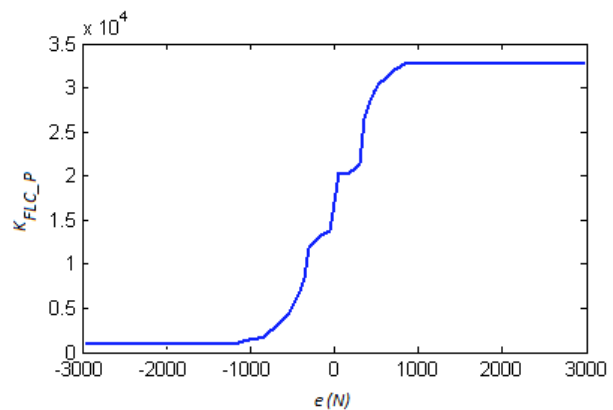

Fig. 3. Control curve of the FLC P controller.

##### B. Hybrid FLC PID Controller

This hybrid real-time-based controller applies a non-linear function to the past, current and future's error, through five SISO FLC and a SIMO FLC: two FLC P were design to

define the proportional error action; a FLC (Aux) to launch the switch between FLC Ps, in order to avoid large overshoots at low force tracking tasks; a FLC I to control the integral error role; and a FLC D to control the error change. An anti-windup technique was also included. Figure 4 and 5 shows its block diagram and state chart. Equation 2 and 3 present its mathematical formulation. FLC Ps were also designed with eighteen fuzzy sets, much like the FLC P from previous section. FLC (Aux) was designed with a couple of fuzzy sets for the input force reference and a couple for each output. It was put into operation a FLC I and a FLC D to improve the controller performance: on the one hand, the FLC I only turns on the integral coefficient for errors closed to zero; on the other, the FLC D function only allows a derivative contribution for errors far away from the neighborhood of no error. The parameter optimization was attained through manual iterative optimization tuning, which conducted to:  $K_{FP1} = 1.74$ ,  $K_{FP2} = 1.74$ ,  $K_I = 20$  and  $K_D = 0.001$ . Figures 6, 7 and 8 point up their control curves. The main contribution of this hybrid design is to use fuzzy rules to ensure the switch between several control states, taking all the advantages about smooth switch control and selecting-control-by-range.

$$F_{FLC\_PID}(t) = K_{FLC\_P}(e(t), F) + K_I K_{FLC\_I}(e(t)) \int_0^t e(t) dt + K_D K_{FLC\_D} \frac{de(t)}{dt} \quad (2)$$

$$K_{FLC\_P}(t) = \begin{cases} K_{FP1} K_{FLC\_P1}(e(t)) & F < 1480 \text{ N} \\ K_{FP2} K_{FLC\_P2}(e(t)) & F > 1520 \text{ N} \end{cases} \quad (3)$$

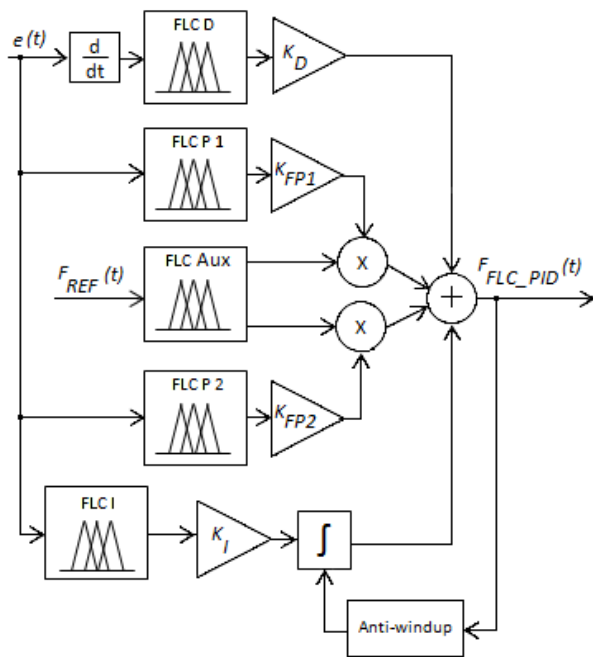

Fig. 4. Block diagram of the FLC PID controller.

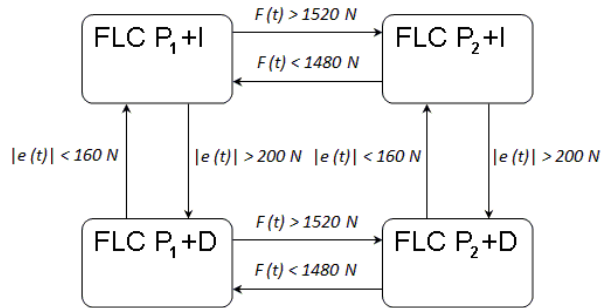

Fig. 5. State chart of the FLC PID controller.

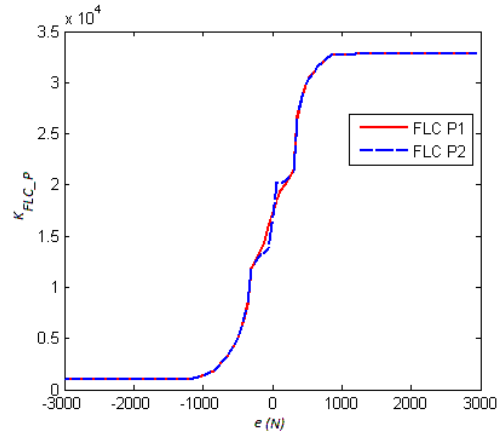

Fig. 6. Control curves of the FLC P 1 and FLC P 2.

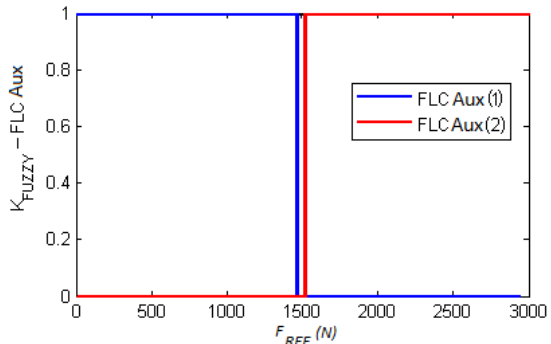

Fig. 7. Control curves of the FLC Aux.

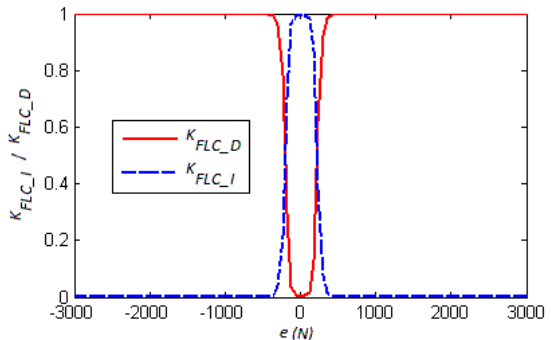

Fig. 8. Control curves of the FLC I and FLC D.

C. Linear PID Controller

A linear controller was also used to experimentally evaluate the performance of FLC P and FLC PID controllers. It has the following control law:

$$F_{PID}(t) = K_P e_{PID}(t) + K_I \int_0^t e_{PID}(t) dt + K_D \frac{de_{PID}(t)}{dt} \quad (4)$$

An anti-windup technique was design to avoid the large increase of the integral action. Its parameters were found through manual tuning, after the application of the Ziegler-Nichols method (in fact, the maximum contribution of PID automatic tuning methods is only provide good initial estimations for an iterative-based approximation [24]), which conducted to:  $K_P = 14$ ;  $K_I = 26$ ; and  $K_D = 0.02$ .

VI. EXPERIMENTAL RESULTS

A. Force Tracking Results

Figures 9 to 15 make experimental results clear, namely through several steps and sinusoidal tracking tasks response, which were discussed from tables I to III. All experiences were conducted using a 200 N/mm spring, to simulate fatigue tests on hip or knee prosthesis. The servovalve's operation is based on the mass flow regulation, which performance is quite different from a servovalve's pressure regulating operation.

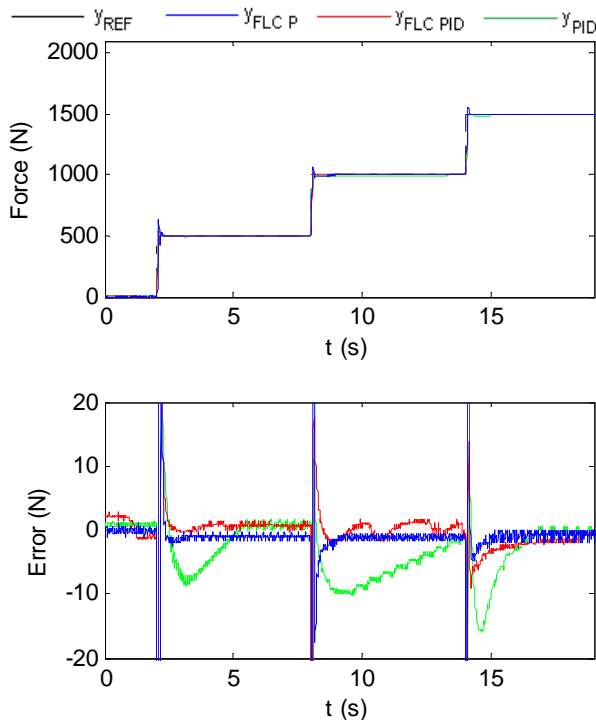

Fig. 9. PID, FLC P and FLC PID controllers' response to step tracking tasks – test 1.

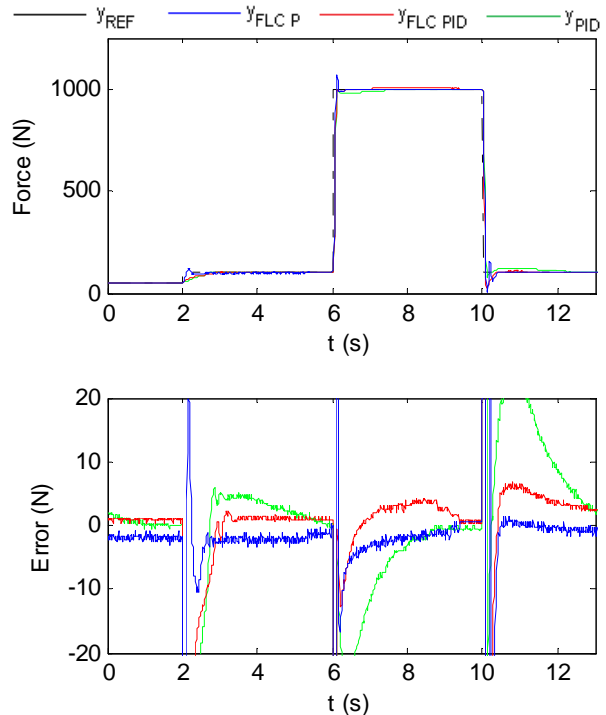

Fig. 10. PID, FLC P and FLC PID controllers' response to step tracking tasks – test 2.

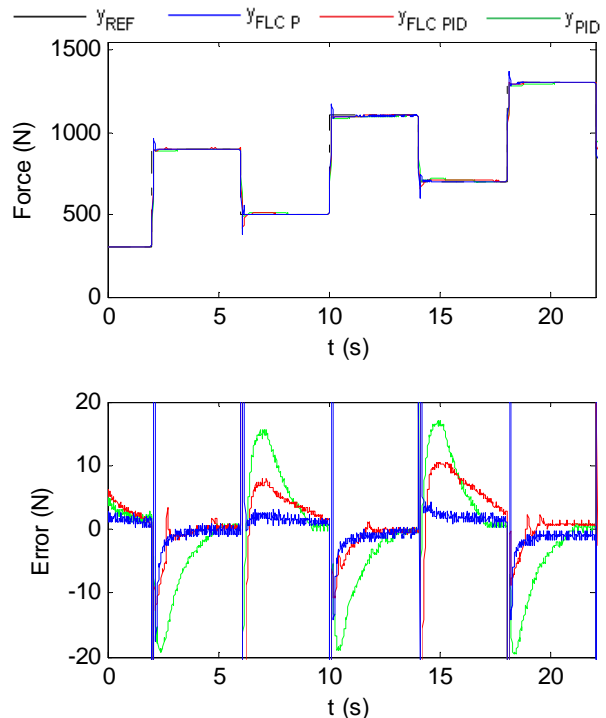

Fig. 11. PID, FLC P and FLC PID controllers' response to step tracking tasks – test 3.

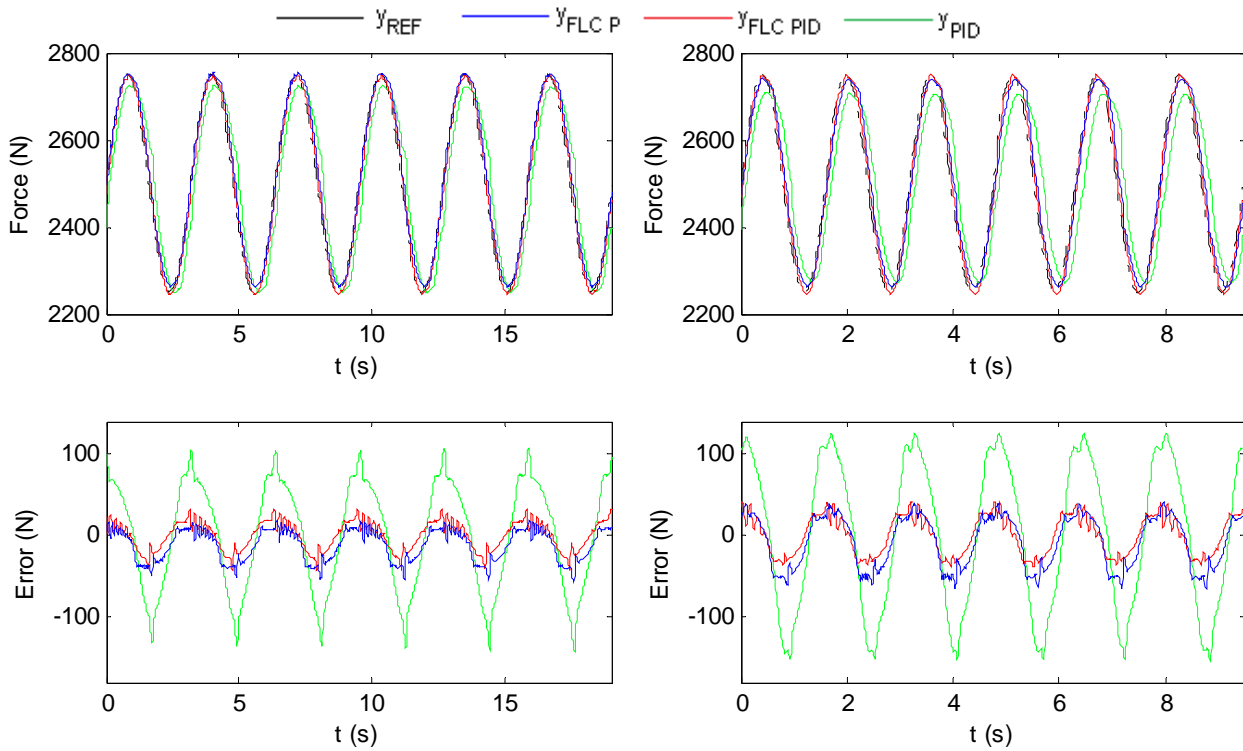

Fig. 12. PID, FLC P and FLC PID controllers' response to sinusoidal tracking tasks S1 (left  $1/\pi$  Hz; right  $2/\pi$  Hz).

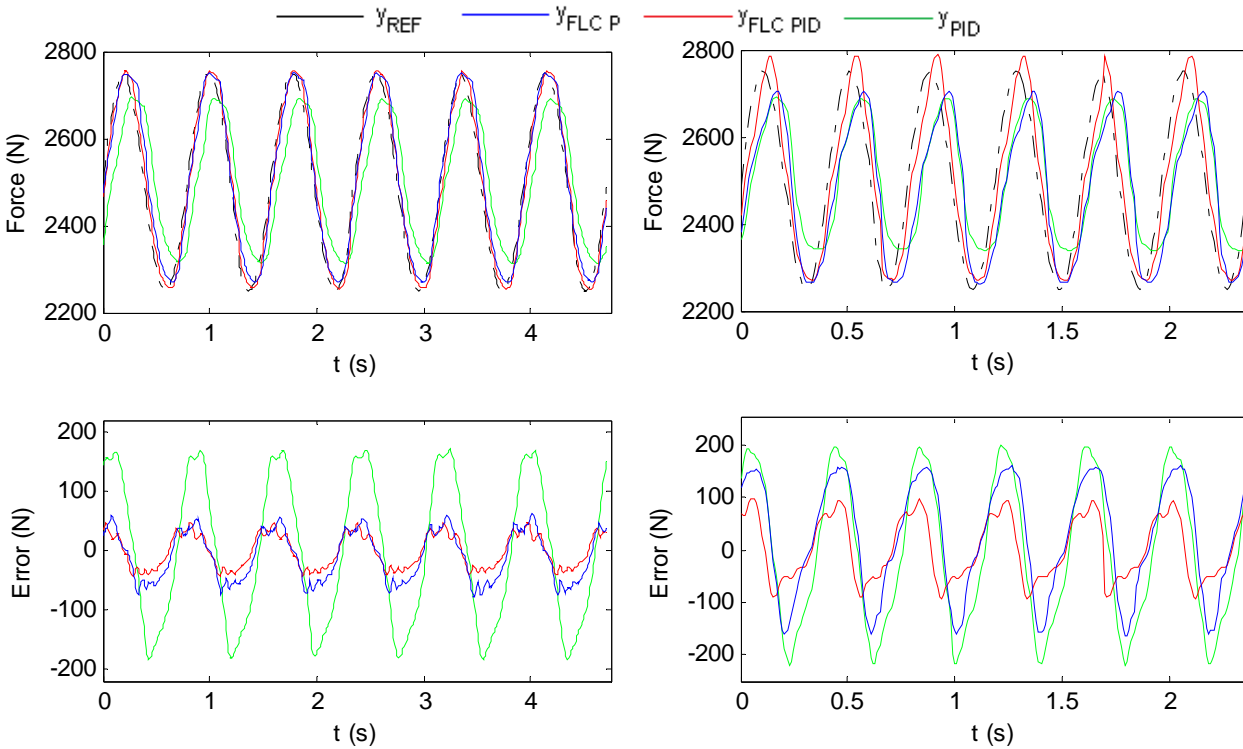

Fig. 13. PID, FLC P and FLC PID controllers' response to sinusoidal tracking tasks S1 (left  $4/\pi$  Hz; right  $8/\pi$  Hz).

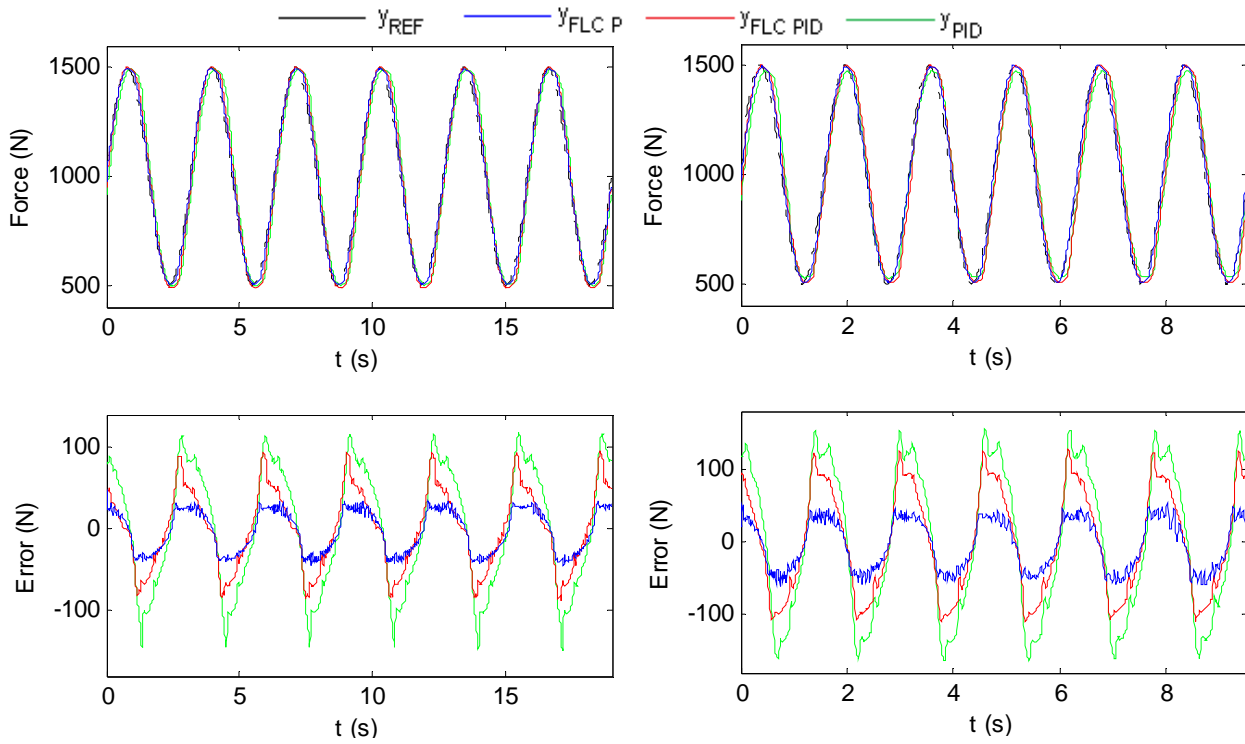

Fig. 14. PID, FLC P and FLC PID controllers' response to sinusoidal tracking tasks S2 (left –  $1/\pi$  Hz; right –  $2/\pi$  Hz).

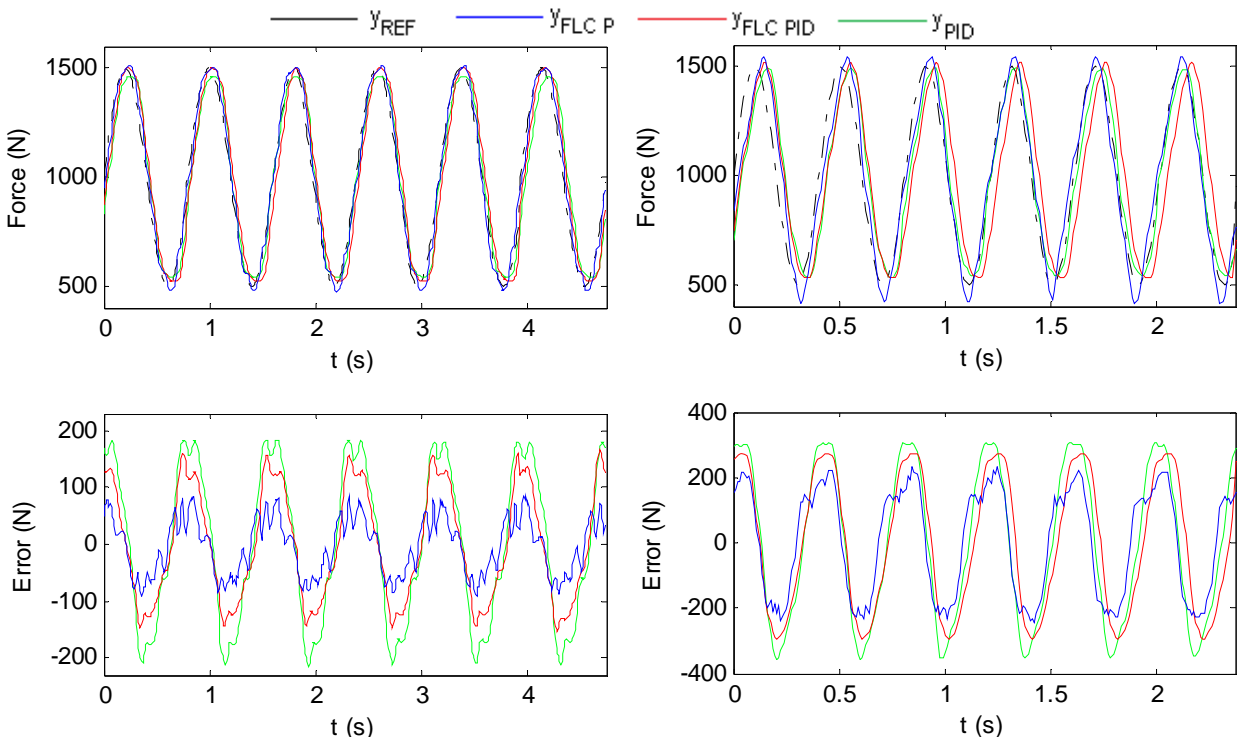

Fig. 15. PID, FLC P and FLC PID controllers' response to sinusoidal tracking tasks S2 (left –  $4/\pi$  Hz; right –  $8/\pi$  Hz).

**B. Performance Analysis and Discussion**

For the step tracking test, the mean squared error (MSE), maximum overshoot (MO), minimum steady-state error (mEE) and maximum steady-state error (MEE) were the chosen criteria to evaluate controllers' performance. For sinusoidal tracking test, MSE and the maximum sinusoidal tracking error (ESM) were used. Figures 16 to 19 were built with the performance results from table I to IV.

TABLE I  
CONTROLLERS' RESPONSE TO SEVERAL STEPS

Criteria Evaluation	Tracking Task (PID   FLC P   FLC PID)		
	Test 1	Test 2	Test 3
MSE (N <sup>2</sup> )	1608   1715   1629	5663   5170   4830	2759   2533   2617
MO (%)	10.65   27.54   8.16	12.18   41.33   8.47	4.37   29.56   20.98
mEE  (N)	<1   <1   <1	<1   <1   <1	<1   <1   <1
MEE  (N)	<1   <1   <1	<1   <1.5   <1	<1   <1.5   <1.5

TABLE II  
CONTROLLERS' RESPONSE TO SINUSOIDAL TRACKING TASKS

Tracking Task S1	Criteria Evaluation (PID   FLC P   FLC PID)	
	MSE (N <sup>2</sup> )	ESM  (N)
1/π Hz	4382   513.5   305	143.1   56.5   42
2/π Hz	8262   1052   570	153.7   65.9   42.3
4/π Hz	14862   1838   815	183.9   78.8   47.9
8/π Hz	19457   11992   3585	219.3   165.3   96.7

TABLE III  
CONTROLLERS' RESPONSE TO SINUSOIDAL TRACKING TASKS

Tracking Task S2	Criteria Evaluation (PID   FLC P   FLC PID)	
	MSE (N <sup>2</sup> )	ESM  (N)
1/π Hz	5445   671   2300	148.7   47.2   94.9
2/π Hz	10409   1232   5236	164.5   61.9   126.5
4/π Hz	18312   2526   9786	214.5   91.2   165
8/π Hz	56080   27153   44149	358.4   243.3   293.9

Steady-state force errors lower than 1.5 N have been achieved. In relation to sinusoidal reference S1, tracking errors lower than 42 N were achieved for 1/π Hz (FLC PID), lower than 42.3 N for 2/π Hz (FLC PID), lower than 47.9 N for 4/π Hz (FLC PID) and lower than 96.7 N for 8/π Hz (FLC PID). In relation to sinusoidal reference S2, tracking errors lower than 47.2 N were achieved for 1/π Hz (FLC P), lower than 61.9 N for 2/π Hz (FLC P), lower than 91.2 N for 4/π Hz (FLC P) and lower than 243.3 N for 8/π Hz (FLC P).

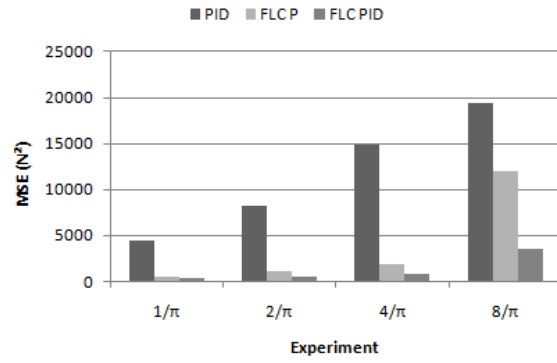

Fig. 16. MSE analysis of several sinusoidal tracking responses – S1.

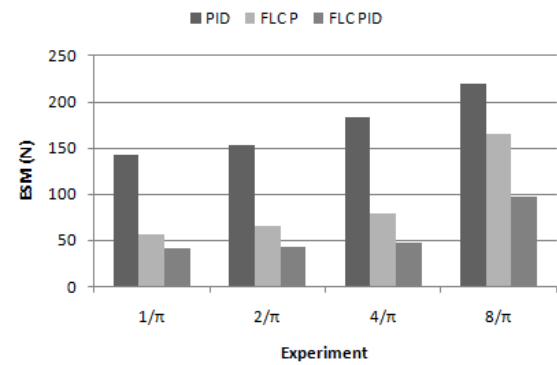

Fig. 17. ESM analysis of several sinusoidal tracking responses – S1.

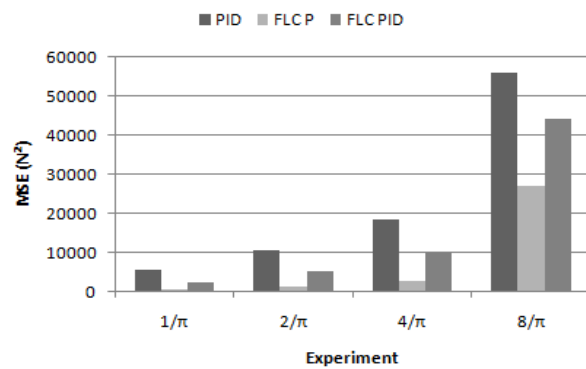

Fig. 18. MSE analysis of several sinusoidal tracking responses – S2.

Both FLC's controllers have much better performance than PID controller. It is well-known the FLC PID's best results over 1.5 kN and the good performance of the FLC P up to 1.5 kN. However, the overshoot levels of the hybrid FLC PID were always lower than the results found by the FLC P. In fact, the main goal about FLC PID was overcoming the control problems about tracking forces over 1.5 kN. These results have proved that it is possible to overcome difficulties about pneumatic control with these fuzzy logic designs, which do not require for a mathematical model that can explicit the pneumatic process' nonlinearities.



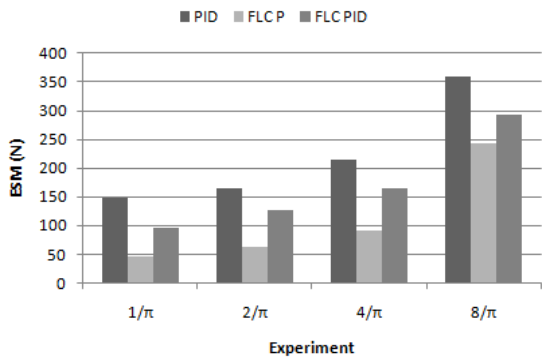

Fig. 19. MSE analysis of several sinusoidal tracking responses – S2.

VII. CONCLUSION

This paper proposes high performance nonlinear Fuzzy Logic force controllers. A servopneumatic control system was put into operation with LabVIEW software and CompactRIO® hardware. A hybrid fuzzy Real-Time-based and Selecting-Control-by-Range controller FLC PID was tested and compared with a FLC P and a PID controller for the force control of a servopneumatic fatigue system. Several fuzzy rules were developed to perform a smoothness switch between the several FLC PID control states. FLC PID ensures the best sinusoidal tracking performance, much better than PID controller results. All controllers point up steady-state errors lower than 1.5 N, without retuning the controllers. The major evidences appear with sinusoidal tracking tasks, namely about tracking forces over 1.5 kN, though the mathematical model of the servopneumatic fatigue machine was despised.

All the criteria evaluation used for controllers’ performance analysis for several steps and sinusoidal tracking tasks has confirmed the skills of FLC P and FLC PID designs to deal with the highly nonlinearities of the pneumatic control.

The next research step is the development of the servopneumatic system’s mathematical model to compare simulated and experimental results. The design of an automatic tuning algorithm to perform the optimization of fuzzy sets, rules and parameters of the FLCs controllers, using genetic-based search algorithms, is also planned.

APPENDIX

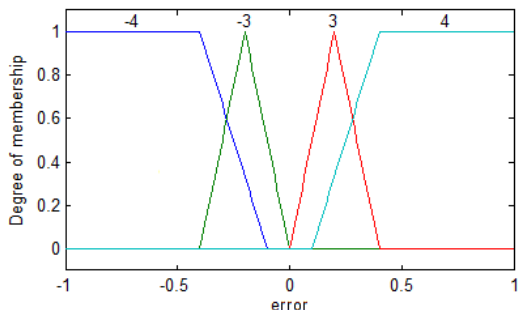

Fig. 20. Four of the nine fuzzy sets of the input error of the FLC P.

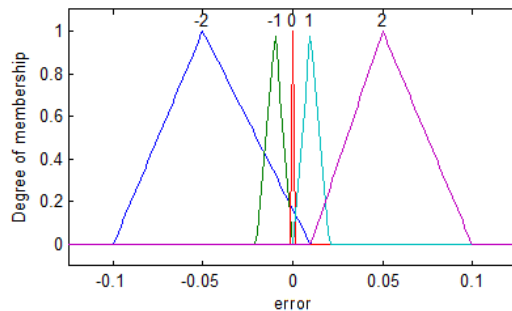

Fig. 21. Remaining five of the nine fuzzy sets of the input error of the FLC P.

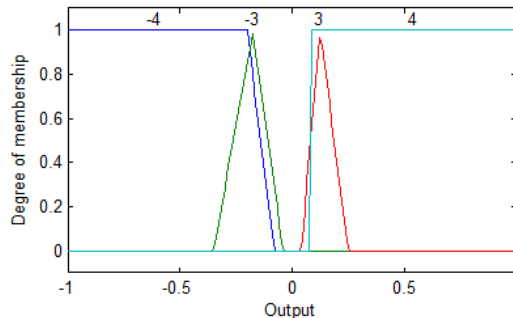

Fig. 22. Four of the nine fuzzy sets of the output of the FLC P.

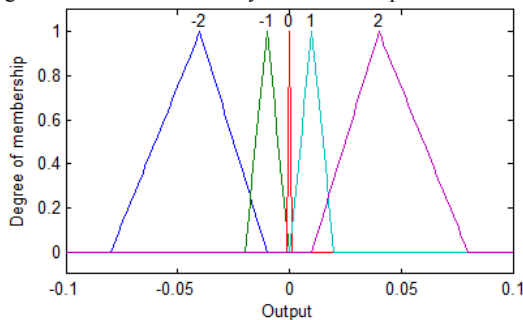

Fig. 23. Remaining five of the nine fuzzy sets of the output of the FLC P.

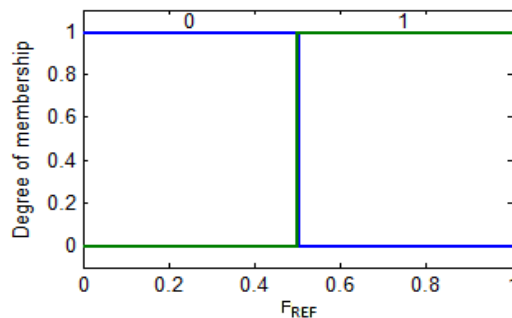

Fig. 24. Fuzzy Sets of the input F<sub>REF</sub> of the FLC Aux.

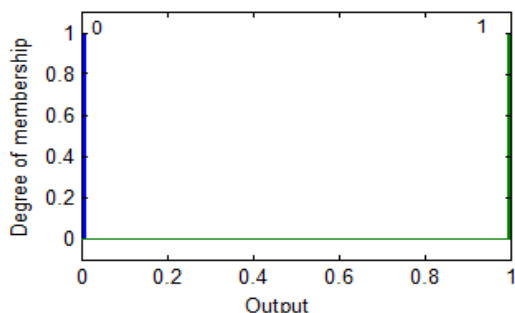

Fig. 25. Fuzzy Sets of the output of the FLC Aux.

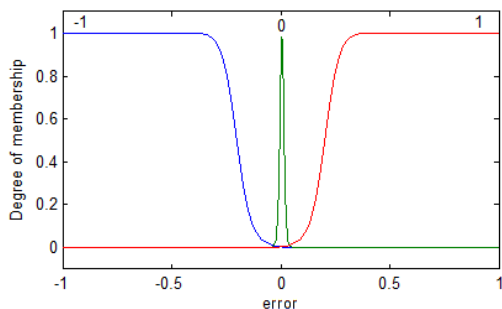

Fig. 26. Fuzzy sets of the input error of the FLC I and FLC D.

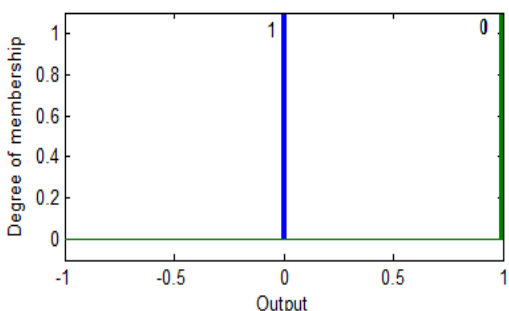

Fig. 27. Fuzzy Sets of the output of the FLC I and FLC D.

TABLE IV  
RULE TABLE F OF THE FLC PS

$K_{FLC P1/P2}$	Linguistic values $e_{FLC P}(t) / e_{FLC PID}(t)$								
	-4	-3	-2	-1	0	1	2	3	4
	-4	-3	-2	-1	0	1	2	3	4

TABLE V  
RULE TABLE OF THE FLC AUX OUTPUTS

	Linguistic values F (t)	
	0	1
$K_{FUZZY-FLC Aux(1)}$	0	1
$K_{FUZZY-FLC Aux(2)}$	1	0

TABLE VI  
RULE TABLE OF THE FLC I AND FLC P OUTPUTS

	Linguistic values F (t)		
	-1	0	1
$K_{FLC D}$	1	0	1
$K_{FLC I}$	0	1	0

REFERENCES

- [1] R. Pedro, "Controlo não Linear de um Servo-mecanismo Pneumático", *Master Thesis in Automation, Instrumentation and Control*, FEUP, University of Porto, Portugal, 2004.
- [2] J. Carneiro, F. Almeida, "Modeling Pneumatic Servovalves Using Neural Networks" in *Proc. IEEE Conference on Computer Aided Control Systems Design*, Munich, Germany, 2006, pp. 790-795.
- [3] J. Ferreira, F. Almeida, M. Quintas, "Semi-empirical model for a hydraulic servo-solenoid valve", in *Proc. Instn Mech. Engrs, Part I, Journal of Systems and Control Engineering*, vol. 216, 2002, pp. 237-248.
- [4] J. Carneiro, "Modelação e Controlo de Actuadores Pneumáticos Utilizando Redes Neurais Artificiais", *PhD Thesis in Mechanical Engineering*, University of Porto, Portugal, 2007.
- [5] K. Suzumori, S. Endo, T. Kanda, N. Kato, H. Suzuki, "A Bending Pneumatic Rubber Actuator Realizing Soft-bodied Manta Swimming Robot", in *Proc. IEEE International Conference on Robotics and Automation*, Roma, Italy, 2007, pp. 4975-4980.
- [6] E. Mangan, D. Kingsley, R. Quinn, H. Chiel, "Development of a Peristaltic Endoscope", in *Proc. IEEE International Conference on Robotics and Automation*, Washington, DC, EUA, 2002, pp. 347-352.
- [7] A. Pujana-Arrese, J. Arenas, I. Retolaza, A. Martinez-Esnaola, J. Landaluze. "Modelling in Modelica of a Pneumatic Muscle: Application to model an Experimental Set-up", in *Proc. 21st European Conference on Modelling and Simulation*, 2007.
- [8] E. Richer, Y. Hurmuzlu. "A High Performance Pneumatic Force Actuator System: Part II – Nonlinear Controller Design", *ASME Journal of Dynamic Systems Measurement and Control*, vol. 122, no.3, pp. 426-434, 2000.
- [9] F. Xiang, J. Wikander. "Block-oriented Approximate Feedback Linearization for Control of Pneumatic Actuator System", *Control Engineering Practice*, vol. 12, no. 4, pp. 387-399, 2004.
- [10] P. Dufour, "Control Engineering in Drying Technology: Review and Trends", *Drying Technology*, vol. 24, no. 7, pp. 889-904, 2006.
- [11] K. Passino, S. Yurkovich. "Fuzzy Control", *Addison Wesley Longman*, Menlo Park, CA, 1998.
- [12] H. Zhang, D. Liu, "Fuzzy Modeling and Fuzzy Control", *Birkhäuser, Control Engineering*, Boston, USA, 2006
- [13] S. Tzafestas, A. Venetsanopoulos, "Fuzzy Reasoning in Information, Decision and Control Systems", *Kluwer Academic Publishers, Microprocessor-based Systems Engineering*, Norwell, MA, USA, 1994
- [14] H. Liu, J. Lee, B. Li, "High Precision Pressure Control of a Pneumatic Chamber Using a Hybrid Fuzzy PID Controller", *International Journal of a Precision Engineering and Manufacturing*, vol. 8, no. 3, pp. 8-13, 2007.
- [15] S. Kaitwanidvilai, M. Parnichkun, "Force Control in a Pneumatic System Using Hybrid Adaptive Neuro-fuzzy Model Reference Control", *Mechatronics* vol. 15, pp. 23-41, 2005.
- [16] C. Ying, Z. Jia-fan, Y. Can-jun, N. Bin, "Design and Hybrid Control of the Pneumatic Force-feedback Systems for Arm-Exoskeleton by Using On/off Valve", *Mechatronics* vol. 17, pp. 325-335, 2007.
- [17] L. Ruihua, S. Weixiang, Y. Qingyu, "Multi-region Fuzzy Tracking Control For a Pneumatic Servo Squeezing Forces System", in *Proc. 5th World Congress on Intelligent Control and Automation*, Hangzhou, China, 2004, pp. 4504-4507.
- [18] B. Kosko, "Neural Networks and Fuzzy Systems", *Prentice-Hall*, 1992.
- [19] L. Wang, "Adaptative Fuzzy Systems and Control", *Prentice-Hall*, 1994.
- [20] M. Santos, P. Talaia, A. Ramos, J. Ferreira, M. Oliveira, "Servo-Pneumatic Machine to Perform and Monitor Tests on Biomechanical Devices", in *Proc. of the 8th Portuguese International Conference on Automatic Control*, Vila Real, Portugal, 2008, pages 784-789.
- [21] M. Santos, "Controlo de um Sistema Servopneumático para Ensaio de Fadiga", *Master Thesis in Industrial Automation Engineering*, University of Aveiro, Aveiro, Portugal, 2009.
- [22] J. Ferreira, P. Sun, J. Grácio, "Design and Control of a Hydraulic Press", in *Proc. IEEE Conference on Computer Aided Control Systems Design*, Munich, Germany, 2006, pp. 814- 819.
- [23] P. MacVicar-Whelan, "Fuzzy sets for man-machine interaction", *Intl. J. Man-Machine Studies*, vol. 8, pp. 687-697, 1976.
- [24] J. Carvalho, "Sistemas de Controlo Automático", *LTC Editora*, Rio de Janeiro, 2000.



**M. P. Soares dos Santos** received the B.S degree in Electronic and Computer Engineering from the Engineering College of the University of Porto, Portugal, in 2004, and the MSc degree in Industrial Automation Engineering from University of Aveiro, Portugal, in 2009.

Since 2006, he integrates the research group of Centre for Mechanical Technology and Automation, at the University of Aveiro. He is preparing the

PhD thesis in Mechanical Engineering at the University of Aveiro. His current research interests include non-linear control and physiologic supply system for in vivo evaluation of orthopedic implants.



**J. A. Ferreira** is graduated in Electronics and Telecommunications Engineering program at the University of Aveiro, Portugal, in 1990. He obtained the M.Sc. degree in Electronics and Telecommunications Engineering in 1994 and the Ph. D degree in Mechanical Engineering in 2003, both from the University of Aveiro. He is now an Assistant Professor in the Mechanical Engineering Department at the University of Aveiro. His research interests transverse the industrial

automation field in areas such as modelling and simulation of physical systems, with more emphasis in fluid power systems, hardware-in-the-loop simulation or instrumentation and control. Recently he joins the Biomechanics group at the University of Aveiro where he has special interests in the area of intelligent bio-devices.



**C. N. Boeri** has a B.S degree in Mathematics (2003) by Regional University Northwestern State of Rio Grande do Sul - Unijui (Brazil), specialization in Mathematics and Physics (2005) from Regional Integrated University of High Uruguay and Missions - Uri (Brazil) and the MSc in Mathematical Modeling (2007) by Unijui, Brazil.

Since April 2008, she integrates the research group of Centre for Mechanical

Technology and Automation – TEMA at the University of Aveiro - Portugal. His PhD thesis in Mechanical Engineering is about modeling and optimization of food products drying. His current research interests include modeling, non-linear control and food drying process.



**F. J. Neto da Silva** is a Professor at Aveiro University since 1997 where he lectures in the fields of Applied Thermodynamics, Thermal Machines, Heat Transfer (Basic and Advanced) and Energy Technologies. F. Neto da Silva is a Mechanical Engineer who graduated from Coimbra University in 1985. He concluded his PhD at Cranfield University in the UK and developed his professional activity both in industry and at Higher Education institutions. The main research subjects are drying, biofuels and

micro-cogeneration.