

Generalized Mathematical Description and Simulation of Grid-Tied Thyristor Converters

V. S. Klimash, Ye Min Thu

Abstract—Thyristor rectifiers, inverters grid-tied, and AC voltage regulators are widely used in industry, and on electrified transport, they have a lot in common both in the power circuit and in the control system. They have a common mathematical structure and switching processes. At the same time, the rectifier, but the inverter units and thyristor regulators of alternating voltage are considered separately both theoretically and practically. They are written about in different books as completely different devices. The aim of this work is to combine them into one class based on the unity of the equations describing electromagnetic processes, and then, to show this unity on the mathematical model and experimental setup. Based on research from mathematics to the product, a conclusion is made about the methodology for the rapid conduct of research and experimental design work, preparation for production and serial production of converters with a unified bundle. In recent years, there has been a transition from thyristor circuits and transistor in modular design. Showing the example of thyristor rectifiers and AC voltage regulators, we can conclude that there is a unity of mathematical structures and grid-tied thyristor converters.

Keywords—Direct current, alternating current, rectifier, AC voltage regulator, generalized mathematical model.

I. INTRODUCTION

IN the mathematical description and simulation of AC/DC and DC/AC power electronics devices, it is advisable to consider the parameters in the DC and AC circuits. The introduction of power supply and transmission parameters makes it possible to vary the parameters in the AC and DC circuits and to ensure the universality of the mathematical structure for application in studies of a wide class of converters. Using this approach, we will demonstrate on the example of thyristor rectifiers and AC voltage regulators, the unity of their mathematical structure, on the basis of which a generalized mathematical model of these converters is proposed.

II. THREE-PHASE THYRISTOR CONVERTERS

The scheme of the bridge thyristor rectifier [1], [4] is shown in Fig. 1 (a). It contains six thyristors, indicated by a cross-principle. If, in this scheme, the output terminals are shorted, and a three-phase load of alternating current is connected between the network and the thyristor bridge, then we obtain a

three-phase AC voltage regulator circuit [2], [3], as shown in Fig. 1 (d). Usually, the AC voltage regulator is shown as it is in Fig. 1 (b). In this scheme, the voltage of the network U_C , being distributed between the thyristors U_T and the load U_H , is equal to the sum $U_C = U_T + U_H$. We swap the summands in this sum, and passing to the scheme in Fig. 1, we rearrange the thyristors and the load, respectively. From this permutation and redistribution of voltage on the elements, the total result and the physical processes in the circuit do not change.

If we compare the circuits shown in Figs. 1 (c) and (d), we can see that they are identical. Their thyristors are connected in pairs in parallel and are included in the load circuit. The numbering of thyristors on all circuits also coincides. Phase A includes thyristors VS1 and VS4, phase B includes VS3 and VS6, and finally, phase C includes thyristors VS5 and VS2. On these grounds, it can be asserted that the rectifier can be used as an AC voltage regulator and vice versa. The only difference is that, in the rectifier, the readout of the thyristor control angle α is made from the point of natural commutation, and this point is shifted towards the lag by 30° relative to the phase voltage of the network, and for the AC voltage regulator from 0° of this voltage (the phase-to-neutral voltage transition of the network). The difference is shown in the diagrams of the control pulses shown in Fig. 2.

In an AC voltage regulator, when working on a purely inductive load, the pulses must be wide, with a duration (Fig. 2) not less than the angle $\varphi = 90^\circ$, while in the rectifier with any ratio between R and L loads, they can be as short and dual, following 60° , or they can be wide, with a duration of at least 60° .

The control of wide pulses increases the stability of the operation of the converters, but at the same time, the possibility of using pulse transformers in the output stage of the control system is excluded, only optical isolator is required.

In Fig. 2 of the diagrams, it is possible to switch with shortening of 90-degree pulses to the 60-degree pulses and simultaneous offset of the reference angle of the thyristor control angle α by 30° . Thus, when performing the necessary switching in the power circuit and the control system, the AC voltage regulator becomes the rectifier. The same switching in the block-modular scheme of the generalized mathematical model will allow to investigate physical processes in the rectifier and AC voltage regulator under different types of load.

Klimash Vladimir Stepanovich is Doctor of Technical Sciences, Professor, Department of Industrial Electronics, FSBEI HPE (Komsomolsk-on-Amur State Technical University), Komsomolsk-on-Amur, Russia (phone: 8 (914) 175-00-35; e-mail: klimash@yandex.ru).

Ye Min Thu is postgraduate student of the Department of Applied Mathematics and Informatics FSBEI HPE Komsomolsk-on-Amur, Russia (phone: 8 (962) 2890106; e-mail: mryemintu08@gmail.com).

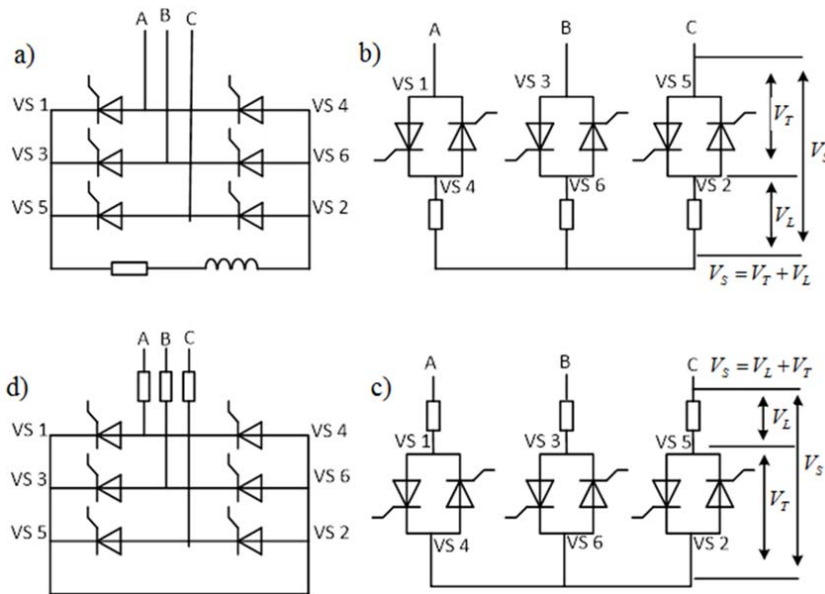

Fig. 1 Three-phase bridge converters (a) – rectifier; (b)-(d) – regulators of alternating voltage

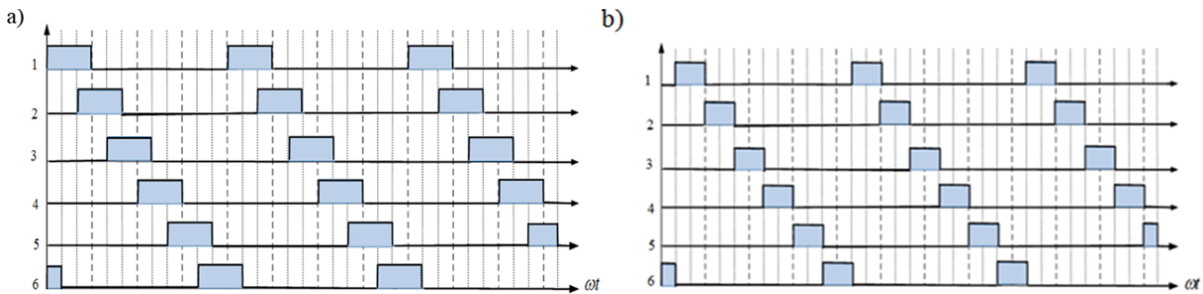

Fig. 2 Control pulse diagrams for the AC voltage regulator (a) and the rectifier (b)

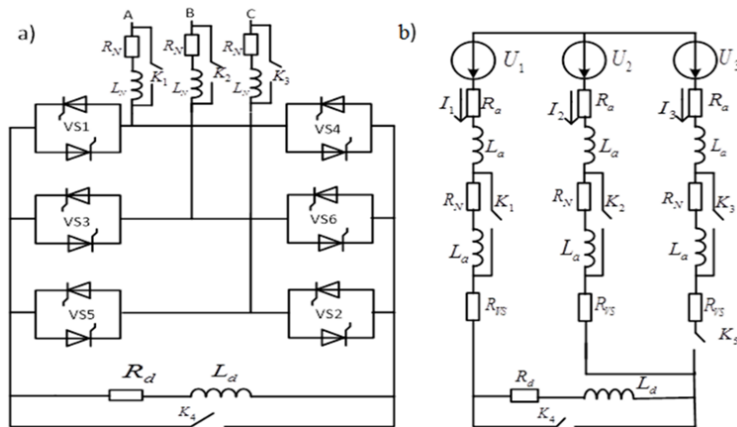

Fig. 3 The generalized circuit diagram (a) and equivalent circuit for replacing bridged thyristor converters (b)

III. GENERALIZED MATHEMATICAL DESCRIPTION OF GRID-TIED THYRISTOR CONVERTERS

Converters with network-synchronized control systems or grid-tied converters are highlighted in a separate class. These include rectifiers and grid-tied inverters, AC voltage regulators and cycloconverters, reversible and recuperative

converters for AC and DC drives [6]. The generalized circuit diagram is shown in Fig. 3 (a), and the corresponding equivalent circuits for replacing bridged thyristor converters are shown in Fig. 3 (b). From the circuit diagram (Fig. 3 (a)) and the substitution (replacing) circuit (Fig. 3 (b)), it can be seen that the three-phase bridge rectifier and the three-phase

AC voltage regulator have much in common. The regulator can be obtained from the rectifier by injecting the load of the rectifier (key K4 is closed) and increasing the resistance in the input circuit (keys K1, K2, K3 are open). This feature made it possible to compose one generalized system of equations describing electromagnetic processes in converters of the class under consideration.

We will carry out approbation of the proposed approach to the studying of converters using the example of three schemes - bridge three-phase thyristor rectifier (BTR), three-phase thyristor controller of alternating voltage (TRV), and a converter with loads in DC and AC circuits - ballast [5].

There are two modes (intervals) of operation of thyristors in the bridge circuit.

- 1) There are two thyristors in operation:
 - a) TRV is referred to as two-phase conductivity intervals;
 - b) BTR is referred to as inter-commutation interval.
- 2) There are three thyristors in operation:
 - a) BTR is referred to as three-phase conductivity intervals;
 - b) TRV is referred to as commutation interval.

Also used for both converters are terms - intermittent current mode, dead time (off period).

The generalized mathematical model takes into account the

$$\frac{dI_2}{dt} = \frac{U_1 - U_2 - 2 \cdot (2R_{VS} + R_a + 2K_n R_n + K_d R_d) + (R_{VS} + R_a + K_n R_n)}{3(L_a + K_n L_n) + 2K_d L_d} \frac{L_a + K_n L_n + K_d L_d}{L_a + K_n L_n} - \frac{I_3(2R_{VS} + R_a + 2K_n R_n + K_d R_d) - (R_{VS} + R_a + K_n R_n)}{3(L_a + K_n L_n) + 2K_d L_d} \frac{L_a + K_n L_n + K_d L_d}{L_a + K_n L_n} - \frac{(U_2 - U_3) \frac{L_a + K_n L_n + K_d L_d}{L_a + K_n L_n}}{3(L_a + K_n L_n) + 2K_d L_d} \quad (2)$$

$$\frac{dI_3}{dt} = \frac{U_2 - U_3 - I_3(R_{VS} + R_a + K_n R_n) + I_2(R_{VS} + R_a + K_n R_n) + \frac{dI_2}{dt}(L_a + K_n L_n)}{L_a + K_n L_n},$$

where I_2, I_3 - Currents in two switched phases (decreasing and increasing accordingly).

The transition from (1) to the system of equations (2) is performed in accordance with the diagram of thyristor switching by control pulses (Fig. 2), and the reverse due to the natural process of switching the thyristor current through zero.

Generalized equations (1) and (2) describe the physical processes of three devices:

- a. Thyristor rectifier, if $K_n = 0$ and $K_d = 1$, i.e. load is on in the DC circuit only;
- b. Regulator of alternating voltage, if $K_n = 1$ и $K_d = 0$, i.e. load is on in the alternating current circuit;
- c. The ballast device, if $K_n = 1$ and $K_d = 1$, i.e. load is on in the alternating current circuit, and the starting rheostat or throttle of saturation in the DC circuit.

IV. MATHEMATICAL MODELING OF THYRISTOR CONVERTERS

A generalized mathematical model [7] is presented in Fig. 4. Here, the AC load is connected between the network and

inductance of the winding of the network transformer or the network inductance, which, together with the inductances of the DC and/or AC loads, affect the duration of the switching process. Due to the fact that, in the switching phases, the current falls not instantaneously, but for a certain time, at the commutation moments in operation three thyristors are simultaneously located.

A generalized differential equation describing the electromagnetic processes in the circuits under study at inter-commutation intervals (two-phase conductivity):

$$\frac{dI_1}{dt} = \frac{U_1 - U_2 - 2 \cdot (R_{VS} + R_a + K_n R_n + K_d R_d) \cdot I_1}{2 \cdot (L_a + K_n L_n) + K_d L_d} \quad (1)$$

where U_1, U_2 - input and output phase voltages; I_1 - input current; R_a, L_a - resistance and inductance of the winding of the mains transformer; R_d, L_d - resistance and inductance of rectifier load; R_n, L_n - resistance and inductance of regulator load; R_{VS} - open thyristor resistance, K_d, K_n - switching functions of the rectifier and regulator.

A generalized system of differential equations describing the electromagnetic processes in the circuits under study at the moment of commutation (three-phase conductivity):

the thyristor unit, and the DC load at the output of the bridge rectifier. The presence of two loads on the AC and DC side finds practical application, for example, in the ballasts of induction motors with a phase rotor. Particular cases of this circuit are the rectifier, when there is no load or AC voltage regulator in the AC circuit, when there is no load in the DC circuit.

The detailed scheme of a three-phase thyristor bridge is shown in Fig. 5, and its control system in Fig. 6.

The thyristor bridge consists of six thyristors, three input clamps of alternating current (1, 2, 3), and two output clamps of direct current (4,5). In addition, the block contains an information output from which the control pulses and voltage for each thyristor are fed to the oscilloscope Os1.

The control input of the thyristor bridge (pulse) is fed by signals from the output (pulse) of the control system (see Figs. 5 and 6).

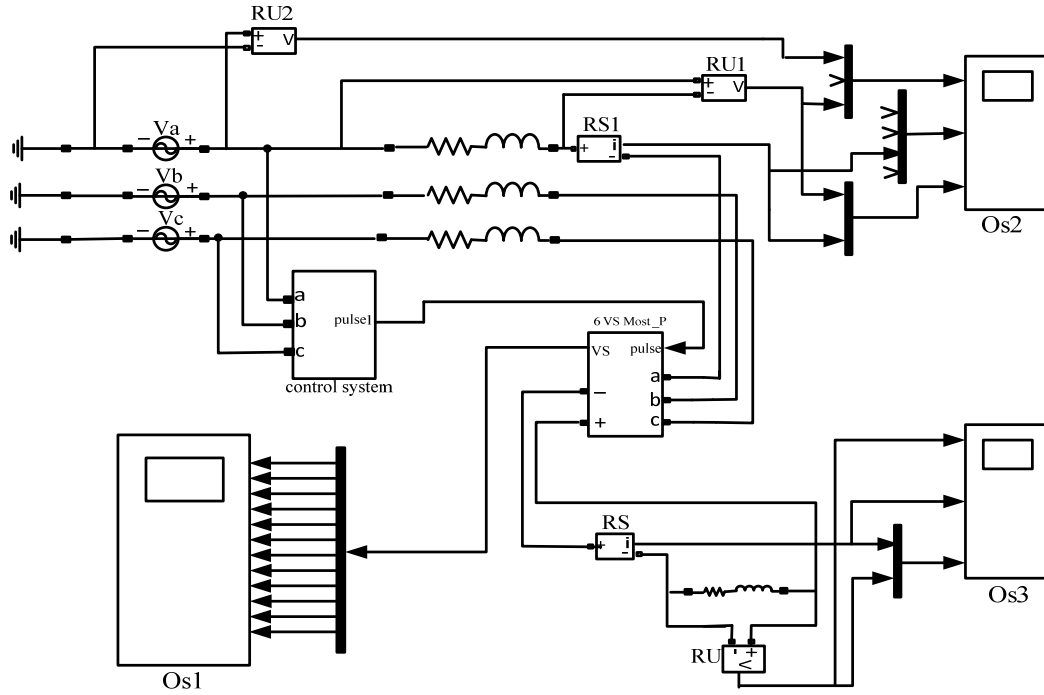

Fig. 4 Generalized block-module mathematical model of bridge converter in MATLAB

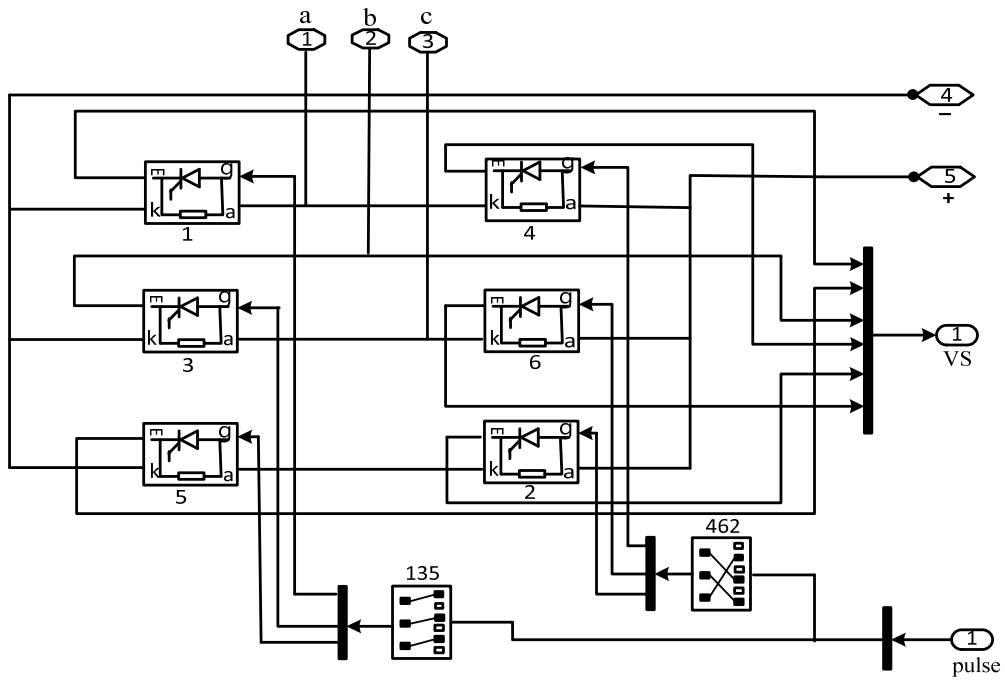

Fig. 5 Diagram of the thyristor bridge module

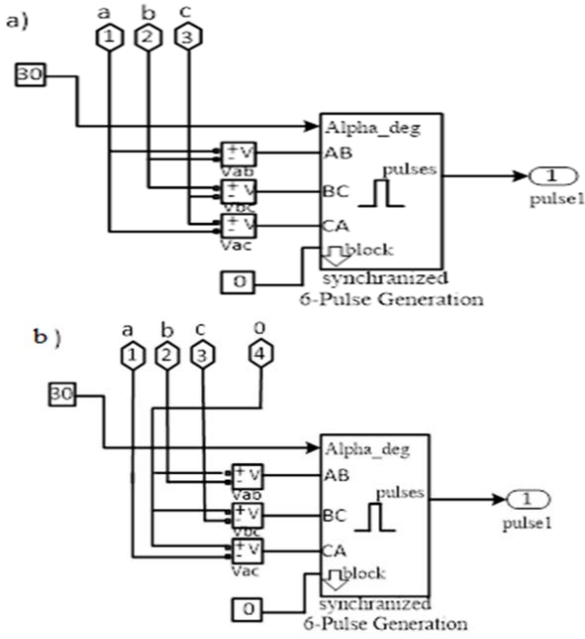

Fig. 6 Diagram of control module for rectifier (a) and controller (regulator) (b)

V. RESEARCH ON MATHEMATICAL MODEL IN THE MATLAB ENVIRONMENT OF THREE-PHASE DEVICES

In Fig. 7, the scheme of model of three-phase bridge regulator of an alternating voltage in MATLAB environment is presented. It is derived from the generalized scheme (see Fig. 3) by switching off the DC load and bridging (shunting) the output terminals of DC 4 and 5 of the three-phase bridge. This electronic device is used for industrial symmetrical loads.

The results of modeling a three-phase AC voltage regulator are represented by oscillograms in Fig. 8. In Fig. 8, the following notations are introduced: U_H - instantaneous voltage on the load; i_{ca}, i_{cb}, i_{cc} - instantaneous values of three-phase mains current; i_d - Rectifying current between thyristor groups.

We perform numerical experiments for an AC voltage regulator with a natural switching TRV-N when working on a symmetrical RL - load with a predominant inductance ($85^\circ < \varphi < 90^\circ$) for different angles α . Such a mode of TRV-N is observed in static compensators of reactive power of a STC with a regulated reactor (regulator mode of the inductive component of the current).

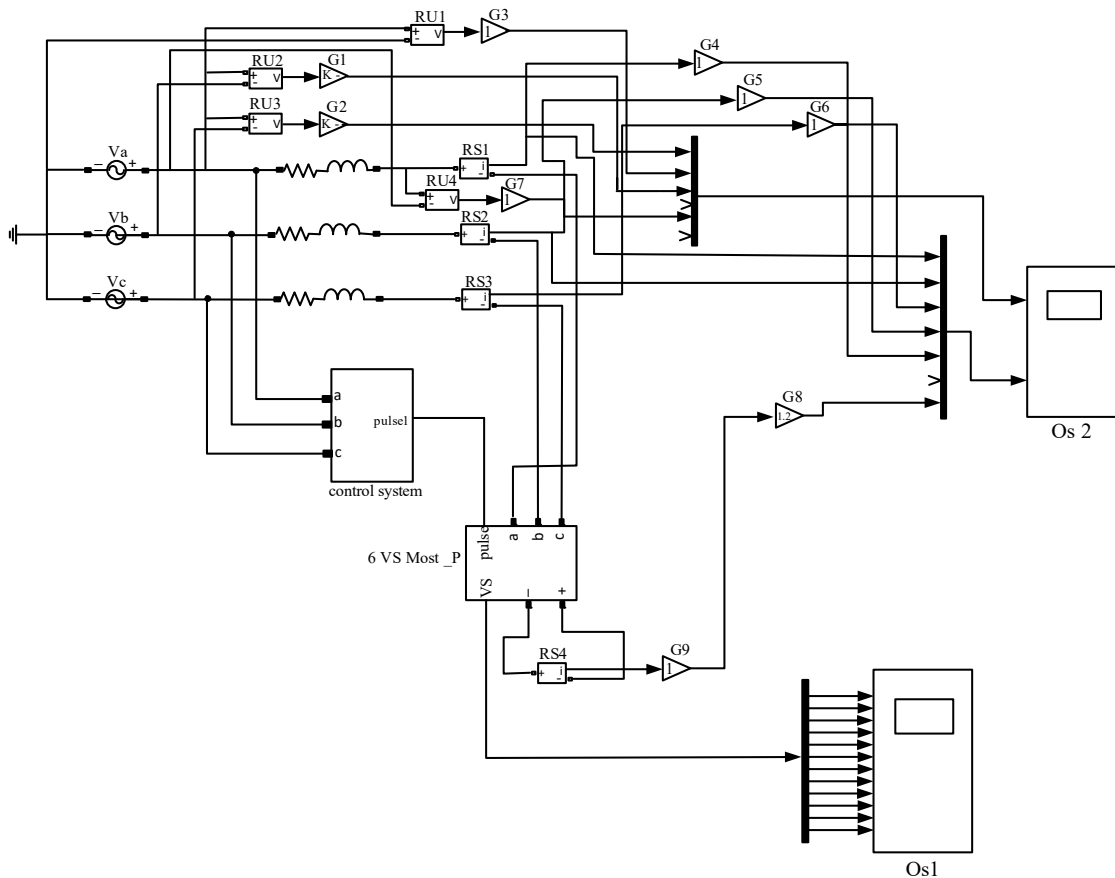
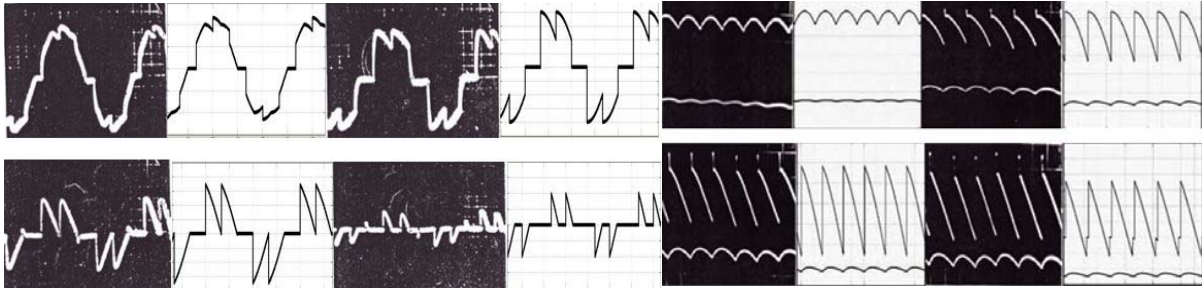

Fig. 7 Three-phase AC voltage regulator model

studies, it was established that the same product can work both as an AC voltage regulator and as a rectifier for any kind of loads in alternating and / or direct current circuits.

Fig. 10 presents a comparative analysis of the voltage and current of one phase of the regulator, obtained by different

methods when the TRV is operated on an RL-load with $\alpha = 60^\circ$. Here, the calculated and experimental curves (Figs. 10 (a) and (b)) are derived from a comparative analysis in Ch. 2-2 of Book [6], and Fig. 10, in the receipt on the model developed by the authors.



(a) Oscillograms of a three-phase AC voltage regulator

(b) Oscillograms of three-phase bridge rectifier

Fig. 9 Oscillograms of the experimental setup and the generalized mathematical model for the regulator of alternating voltage (a) and rectifier (b)

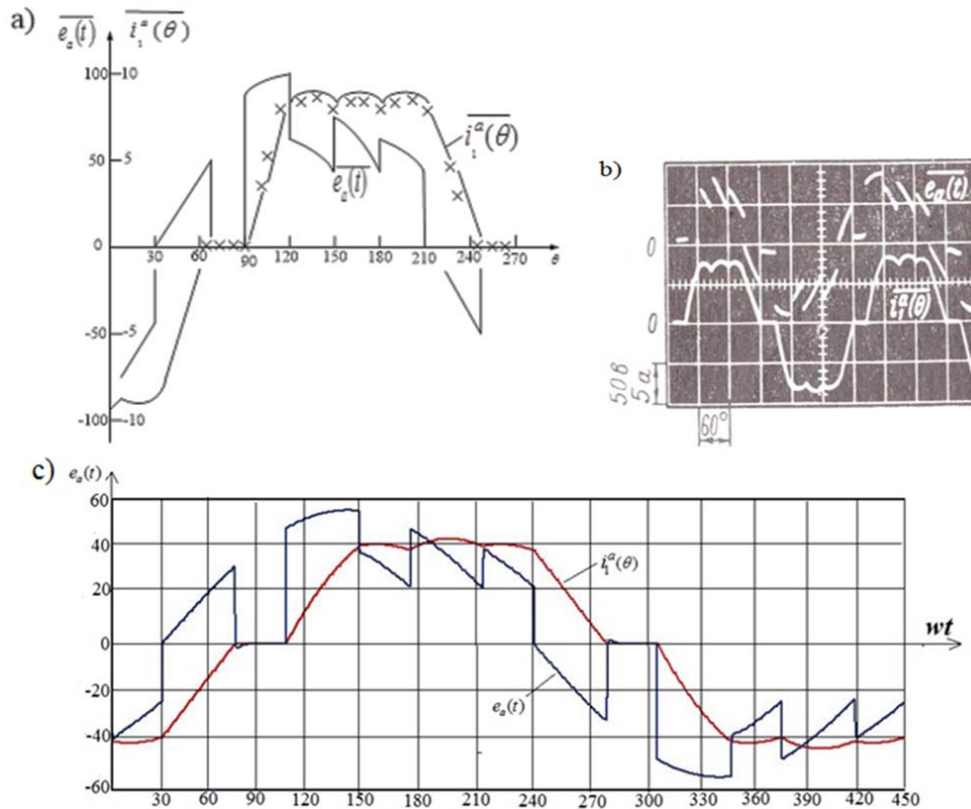

Fig. 10 Voltages and currents obtained from analytical expressions (a), experimentally (b) and the generalized model in MATLAB (c)

When comparing, it is clear that they coincide rather well. Therefore, the generalized mathematical model allows reliably calculating the electromagnetic processes for the considered transducers in transient and stationary modes for any type of load with the detection of any electrical quantity and characteristics of the devices.

VII. CONCLUSION

Oscillograms obtained during mathematical and physical modeling adequately reflect physical processes in rectifiers and AC voltage regulators.

The experimental approbation showed the operability of a three-phase AC voltage regulator made on the basis of a commercially available three-phase bridge rectifier.

Regulators and rectifiers can be produced with a general complete set at one enterprise.

The generalized block-modular model is designed to study not only three-phase bridge converters, but also other power electronics devices. On its basis, construction of models of zero three-phase and bridge single-phase converters is very simple.

The proposed generalized approach to the analytical description and research of processes, their mathematical modeling, predetermines a unified approach to the production of a wide class of converters and significantly reduces the laboriousness in performing research and development work, research and development, testing, compiling and maintaining design documentation and mass production in general.

REFERENCES

- [1] Zabrodin, Yu. S. Industrial Electronics/Yu. S. Zabrodin. - M.: Higher Education, 1982. - 496 p.
- [2] Shubenko, V. A. A thyristor asynchronous electric drive with phase control / V. A. Shubenko, I. Ya. Braslavsky. - M.: Energia, 1972. - 200 p.
- [3] Energy Electronics: A Reference Manual / Trans. From Germ.; Ed. V. A. Labuntsov. - Moscow: Energoatomizdat, 1978. - 464 p.
- [4] Chizhenko, I. M. Fundamentals of transformational technology: Textbook. For higher education institutions / I. M. Chizhenko, V. S. Rudenko, V. I. Senko. - 2 nd ed. - M.: Higher education, 1980. - 424 p.
- [5] Klimash V. S. Fundamentals of converter technology. Tutorial. - Komsomolsk-on-Amur: SEIHPE "Komsomolsk-on-Amur State. Tech. Un-t », 2010. – 100p.
- [6] Takeuchi T, Theory and application of valve circuits for motor control. Trans. from the English. L. "Energy", 1973. - 248 p.
- [7] The certificate of the Russian Federation № 2016617861 about registration of the computer program "Program of the generalized mathematical model in MatLab environment of grid-tied thyristor converters for the study of physical processes" / Klimash VS (RU), Ye Min Thu (RU) // Bul. № 8, August 20, 2016.