

Fuzzy Optimization in Metabolic Systems

Feng-Sheng Wang, Wu-Hsiung Wu, Kai-Cheng Hsu

Abstract—The optimization of biological systems, which is a branch of metabolic engineering, has generated a lot of industrial and academic interest for a long time. In the last decade, metabolic engineering approaches based on mathematical optimizations have been used extensively for the analysis and manipulation of metabolic networks. In practical optimization of metabolic reaction networks, designers have to manage the nature of uncertainty resulting from qualitative characters of metabolic reactions, e.g., the possibility of enzyme effects. A deterministic approach does not give an adequate representation for metabolic reaction networks with uncertain characters. Fuzzy optimization formulations can be applied to cope with this problem. A fuzzy multi-objective optimization problem can be introduced for finding the optimal engineering interventions on metabolic network systems considering the resilience phenomenon and cell viability constraints. The accuracy of optimization results depends heavily on the development of essential kinetic models of metabolic networks. Kinetic models can quantitatively capture the experimentally observed regulation data of metabolic systems and are often used to find the optimal manipulation of external inputs. To address the issues of optimizing the regulatory structure of metabolic networks, it is necessary to consider qualitative effects, e.g., the resilience phenomena and cell viability constraints. Combining the qualitative and quantitative descriptions for metabolic networks makes it possible to design a viable strain and accurately predict the maximum possible flux rates of desired products. Considering the resilience phenomena in metabolic networks can improve the predictions of gene intervention and maximum synthesis rates in metabolic engineering. Two case studies will present in the conference to illustrate the phenomena.

Keywords—Fuzzy multi-objective optimization problem, kinetic model, metabolic engineering.

I. INTRODUCTION

OPTIMIZATION is the process of making something as good or effective as possible. This definition is similar to optimization in a fuzzy environment. More generally, it means finding “best available” values of some objective function given a defined domain, including a variety of different types of objective functions and domains [1]. Regarding to optimization in biology, we should mention Darwin’s evolutionary theory that living organisms have evolved to maximize their chances for survival. The use of optimization has allowed biologists not only to describe patterns or mechanisms but to predict, from first principles, how organisms should be designed [2]. Many articles have been applying optimization methods for solving

The financial support from the National Science Council, Taiwan, ROC (Grant NSC102-2627-B-194-003 and NSC100-2221-E-194-028-MY3) is highly appreciated.

F.S. Wang is with the Department of Chemical Engineering, National Chung Cheng University, Chiayi 62102, Taiwan (phone: +886 5 2720411 ext 33404; fax: +886 5 2721206; e-mail: chmfsw@ccu.edu.tw).

W.H. Wu is with the Department, of Chemical Engineering, National Chung Cheng University, Chiayi 62102, Taiwan (e-mail: wwh@cs.ccu.edu.tw).

biological problems. Model-based optimization problems can be classified as stoichiometric and kinetic models. Stoichiometric models can be obtained through the reaction topology of a network. Stoichiometric models do not require kinetic data and are easy to construct. However, they have shortages of handling regulatory dynamics in a metabolic network. Kinetic models, e.g., generalized mass action (GMA) and Michaelis-Menten formulations are generally formulated as nonlinear equations with more information to describe system characteristics [3]. Indirect optimization methods (IOMs) convert a nonlinear kinetic model into an S-system model [4]. The model becomes a linear system so that the problem can be solved by a linear programming method efficiently.

Optimization problems for metabolic networks can be categorized as single-objective and multi-objective formulations, depending on the design purpose. Most studies on microbial metabolic engineering focus on only a single objective, i.e., maximize the synthesis rate of a desired metabolite. In contrast, a multi-objective optimization approach attempts to find the solutions that are optimal for many objectives simultaneously. However, most approaches are considered optimization in a crisp environment. In general, some biological optimization problems imply finding the best compromise among several conflicting demands in a fuzzy situation. For example, experimental results show that a micro-organism may reflect resilience phenomenon after stressful environmental changes and genetic modification. The resilience phenomenon indicates that a mutant strain tries to recover to its original “wild-type” characteristics. MOMA [5] and ROOM [6] were applied to handle this phenomenon. An optimal design may be over-predicted if we do not consider resilience effects. In this article, a generalized fuzzy multi-objective optimization is introduced to handle resilience effects. We introduce fuzzy programming approaches to determine optimal design for biological systems in a fuzzy environment and then apply to two metabolic network systems for illustrating the approach.

II. METHODS

An optimization problem in a crisp environment can be expressed as follows:

Crisp objective function:

$$\max_{\mathbf{x}} f(\mathbf{x}) \quad (1)$$

Crisp inequality constraints:

$$g_j(\mathbf{x}) \leq 0, j = 1, \dots, p$$

The crisp optimization problem is to find decision variables

\mathbf{x} such that the objective function $f(\mathbf{x})$ should be maximized and fulfilled the constraints $g_j(\mathbf{x})$ completely. Suppose that the vector \mathbf{x}^* in the green area (feasible domain) of Fig. 1 is the maximum point of the crisp optimization problem. According to optimality, the point \mathbf{x}^* is said to be a locally maximum solution, if no point in the neighborhood has a function value greater than $f(\mathbf{x}^*)$. Considering that a point \mathbf{x}^1 located nearby the maximum point \mathbf{x}^* , $f(\mathbf{x}^1) > f(\mathbf{x}^*)$, and one of inequality constraints is greater than zero at the point \mathbf{x}^1 , i.e., $g_j(\mathbf{x}^1) > 0$, is not an optimal solution, because it is outside the crisp feasible domain defined sharply.

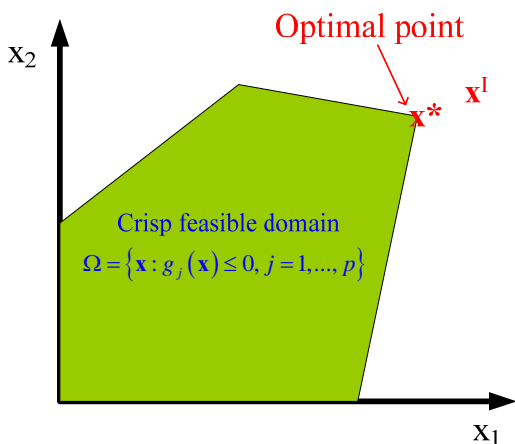

Fig. 1 The feasible domain for a crisp optimization problem

In general, an objective and/or constraints for a biological optimization problem are not sharply defined and flexible. A fuzzy formulation can be applied to describe such flexible situations. The fuzzy optimization problem is expressed as follows:

Fuzzy objective function:

$$\text{Fuzzy max}_{\mathbf{x} \in \Omega \subset \mathbb{R}^n} f(\mathbf{x}) \tag{2}$$

Fuzzy inequality constraints:

$$g_j(\mathbf{x}) \leq [0, \varepsilon_j], j = 1, \dots, p$$

The fuzzy optimization problem is to find decision variables \mathbf{x} such that the objective function $f(\mathbf{x})$ should be maximized as well as possible and the constraints $g_j(\mathbf{x})$ should be possibly well satisfied, respectively. The definition is literally different to the crisp optimization. Fig. 2 shows the feasible domain for fuzzy and crisp optimization problems. In general, the crisp feasible domain is a subset of the fuzzy domain. Both points \mathbf{x}^* and \mathbf{x}^1 on the fuzzy feasible domain are the candidate solutions to the fuzzy optimization problem. Suppose that $f(\mathbf{x}^1) > f(\mathbf{x}^*)$, but the inequalities $g_j(\mathbf{x}^1) = \varepsilon_j > 0$ are less satisfactory than those of \mathbf{x}^* . As a result, a trade-off procedure has to be carried out to obtain a compromise solution for the fuzzy optimization problem. A fuzzy solution, then, may be viewed as an intersection of the given goal and constraints. A satisfactory solution may be obtained by assigning various values of ε_j (a

brute force method), and then solve each problem to obtain the corresponding solution, which is referred to as a candidate solution. The satisfactory solution is then picked up from the candidate solutions. In general, the brute force method is inefficient.

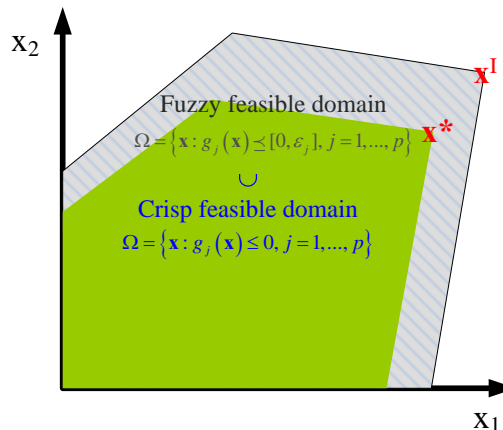

Fig. 2 Description of the crisp and fuzzy feasible domains

We can elicit membership functions to fuzzy objective and constraints in order to solve fuzzy optimization problems. We first define a membership function for each constraint and objective as shown in Fig. 3. The membership function for each fuzzy constraint is a strictly monotonically decreasing function for evaluating the degree of satisfaction. The membership function for objective is defined as a strictly monotone increasing function as shown in the blue curve. The satisfactory grade is zero if the objective is less than its lower bound and one if the objective is greater than its upper bound. By defining each fuzzy objective and fuzzy constraint, the fuzzy optimization problem is then transferred to the maximizing decision problem that is to find maximum intersection of the objective and constraints.

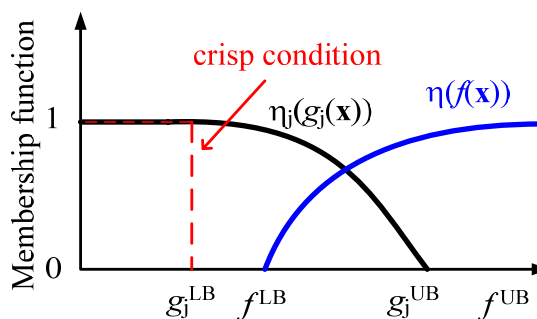

Fig. 3 Description of membership function for objective and inequality constraint

The maximizing decision problem is expressed as follows:

$$\begin{aligned} &\text{Maximizing decision problem:} \\ &\max_{\mathbf{x}} \eta_D(\mathbf{x}) = \max_{\mathbf{x}} \min \left\{ \eta(f(\mathbf{x})), \eta_j(g_j(\mathbf{x})) \right\} \end{aligned} \quad (3)$$

Problem (3) is non-differentiable. To overcome this drawback, the following equivalent problem was introduced.

$$\begin{aligned} &\text{Equivalent problem:} \\ &\max_{\mathbf{x}, \lambda} \lambda \\ &\eta(f(\mathbf{x})) \geq \lambda \\ &\eta_j(g_j(\mathbf{x})) \geq \lambda \end{aligned} \quad (4)$$

The advantage of the approach is that the optimal membership grade is corresponded to the satisfactory level for each objective and constraint, and the optimal decision variable λ^* expresses the overall satisfactory grade for the problem.

III. APPLICATIONS

We apply the fuzzy optimization approach to two metabolic network systems. Improvements in the product yield, rate of production, and final product concentration are common goals in achieving more efficient and cost-effective bioprocesses. The bioprocess improvements can be achieved by two main approaches, process development and genetic modulation. Process improvements involve the adjustment of the environment of the micro-organisms and the optimization of downstream processes to achieve the best possible performance. The aim of process improvements is to evaluate process performance and economics for integrating bioreactor, recovery, separation, purification, and utility. Genetic improvements are based on the use of microorganisms with altered DNA such that their functional characteristics are enhanced. Recent advances in molecular biology enable the routine deletion or modulation of the expression level of genes in microbial production strains. Selecting suitable enzymes from a large scale metabolic network is not straightforward. From computational standpoints, we can apply an optimization model to find some candidate enzymes. There are some questions should be considered in an optimization problem. What is the minimum set of enzymes in a given microorganism that should be modulated and/or knocked-out in order to maximize the synthesis flux of the desired end products and to minimize the synthesis of byproducts, simultaneously?

A. Metabolic Engineering Problem of *E. coli*

In the first case study, we use *E. coli* as an example to explain the fuzzy approach. The central metabolic pathway of *E. coli* is shown in Fig. 4. This case study is to determine the optimal enzyme modulation that maximizes the desired product synthesis rate and minimizes the byproduct secretion, simultaneously. Here, we consider serine as the desired product and glycerol as the byproduct. From a bioprocess engineering standpoint, too much byproduct secretion could cause adverse effects on separation and purification of serine at downstream

processes. Byproducts always result in a separation burden because the capital and operation cost of separation is estimated about 20 to 40 % to total cost. The cost can be reduced if minimizing byproduct secretions was considered in the design of optimal target enzyme.

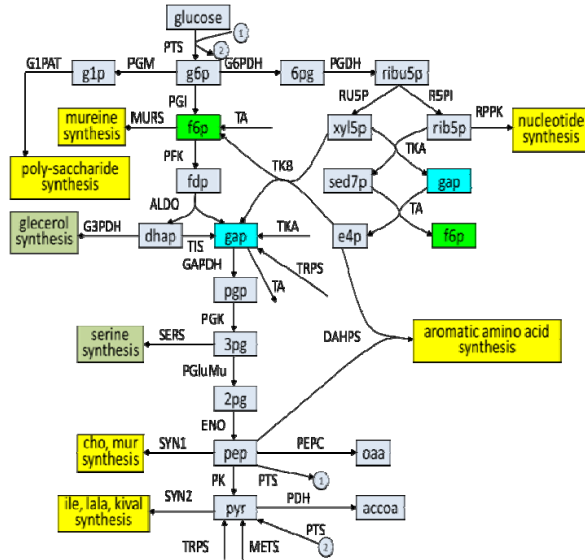

Fig. 4 The central metabolic pathway of *E. coli*

The generalized fuzzy multi-objective optimization problem for *E. coli* is formulated as follows:

Generalized fuzzy multi-objective optimization problem:

$$\begin{cases} \text{Fuzzy max}_{\mathbf{e}, \mathbf{x}, \mathbf{y}} \frac{V_{SerSyn}}{V_{SerSyn}^{basal}} \\ \text{Fuzzy min}_{\mathbf{e}, \mathbf{x}, \mathbf{y}} \frac{V_{G3PDH}}{V_{G3PDH}^{basal}} \\ \text{Fuzzy equal}_{\mathbf{e}, \mathbf{x}, \mathbf{y}} (x_j \approx x_j^{basal}), j \in \Sigma_x \\ \text{Fuzzy equal}_{\mathbf{e}, \mathbf{x}, \mathbf{y}} (e_k \approx e_k^{basal}), k \in \Sigma_E \\ \sum_{i=1}^n x_i \lesssim [\zeta_x^{LB}, \zeta_x^{UB}] \sum_{i=1}^n x_i^{basal} \\ \sum_{i=1}^m e_i \lesssim [\zeta_e^{LB}, \zeta_e^{UB}] \sum_{i=1}^m e_i^{basal} \end{cases}$$

Crisp objective and constraints:

$$\begin{cases} \min_{\mathbf{e}, \mathbf{x}, \mathbf{y}} \sum_{j=1}^m y_j \\ \mathbf{Nv}(\mathbf{x}, \mathbf{e}; \boldsymbol{\theta}) = \mathbf{0} \\ y_i e_i^{LB} + (1 - y_i) e_i^{basal} \leq e_i \leq y_i e_i^{UB} + (1 - y_i) e_i^{basal} \\ \gamma_{x_i}^{LB} x_i^{basal} \leq x_i \leq \gamma_{x_i}^{UB} x_i^{basal} \end{cases} \quad (5)$$

For detailed formulation of the fuzzy multi-objective optimization problem, readers can refer to [7] which considered many maximizing objectives, simultaneously. This study is not

only to maximize the desired product shown in the first objective, but also minimizing the byproduct secretion shown in the second objective. The fuzzy equal operations in (5) are applied to handle resilience effects, which the metabolite concentration and rate constant recover to its basal level as close as possible. The kinetic model of the system consists of 30 enzymatic reactions, 18 metabolites or precursors, and seven co-metabolites.

Three cases are considered in the computation. Case 1 is the crisp single objective optimization problem that is to maximize the serine synthesis rate and without including cell viability constraints. Case 2 is the bi-objective optimization problem that is to maximize the serine synthesis rate and to minimize the glycerol secretion rate, simultaneously, but without including resilience effects. Case 3 is the fuzzy bi-objective optimization problem including resilience effects. Fig. 5 (a) summarizes the maximum serine improved flux ratios using various numbers of allowable modulated enzymes. The glycerol flux ratio is also shown in Fig. 5 (b). We observe that larger the allowable number of the modulated enzymes in the metabolic network, higher the improved serine synthesis rate. The serine synthesis rate got a great improvement if we considered the single maximization problem only, but the byproduct secretion was also in a higher rate. The improved serine synthesis rate in case 3 is less than that obtained by the single optimization problem (case 1), because the resilience problem tries to recover the rate constant and the concentration to the basal levels.

B. Purine Metabolism

The second case study applied fuzzy optimization to identify enzyme targets for purine metabolism in human as shown in Fig. 6. The kinetic model of the purine metabolic pathway described in Curto et al. [4] was expressed as a GMA formulation consisting of 16 dependent variables, 2 diet control variables and 28 independent variables for modulating enzyme activities. The optimization program for drug design (OPDD) is a two-stage procedure used to identify target enzymes for remedying hyperuricemia [8], which is caused by PRPPS overactivity in the purine metabolic pathway. The first stage of the OPDD is the identification of a set of candidate enzyme targets, which minimize the difference between a high concentration of UA and its healthy levels. The GMA model was first transformed into an S-system model, so that the OPDD can be applied to a linear programming method in solving the drug target design problem. The second stage of the OPDD is a posterior decision making determining a satisfactory target from the set of candidate target enzymes.

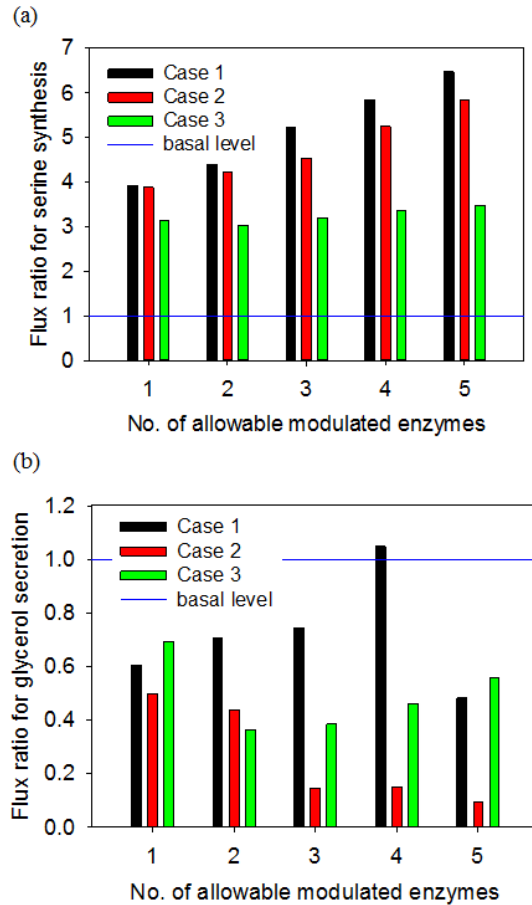

Fig. 5 Ratio for serine synthesis rate and glycerol secretion rate

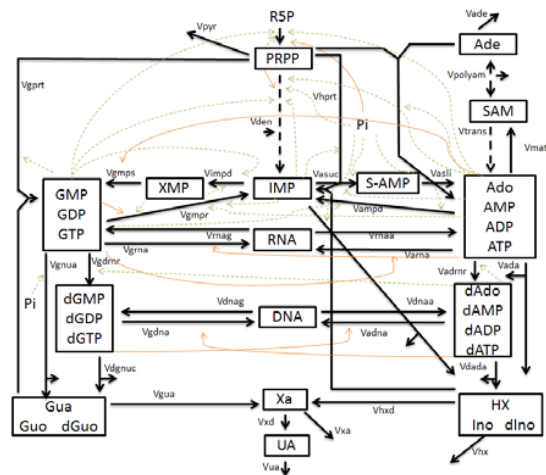

Fig. 6 Diagram of the purine metabolism in humans

We have introduced a fuzzy equal metabolic adjustment approach to formulate the enzyme target design problem for drug discovery into a unified optimization framework [9]. The approach not only considered the therapeutic effect and adverse effect objectives, but also the minimum effective dose (MED)

to represent the low dose objective. Three decision making criteria were combined with the optimal design problem for detecting target enzymes. As a result, the drug design problem was formulated as a mixed-integer nonlinear programming (MINLP) problem. The commercial software, GAMS with BONMIN and KNITRO solvers, were applied to identify target enzymes for curing hyperuricemia caused by PRPPS overactivity and HGPRT deficiency, respectively. In this study, we introduced a nested hybrid differential evolution [10] to solve the MINLP problem including the pathological state caused by PRPPS overactivity and HGPRT deficiency, simultaneously. Fig. 7 shows the overall satisfactory grades with and without prescribed diet control. The detailed computational procedures will discuss in the conference. From Fig. 7, we observe that only one enzyme is unable to achieve the goal for remedying hyperuricemia, which is caused by overactivity of the enzyme PRPPS and HGPRT deficiency. For the case of no prescription diet control, one three-enzyme target {gnuc, ada, den} has the overall satisfactory grade of about 16%. Moreover, if we consider the prescription diet control of R5P and Pi, the overall satisfactory grade can achieve to 54%.

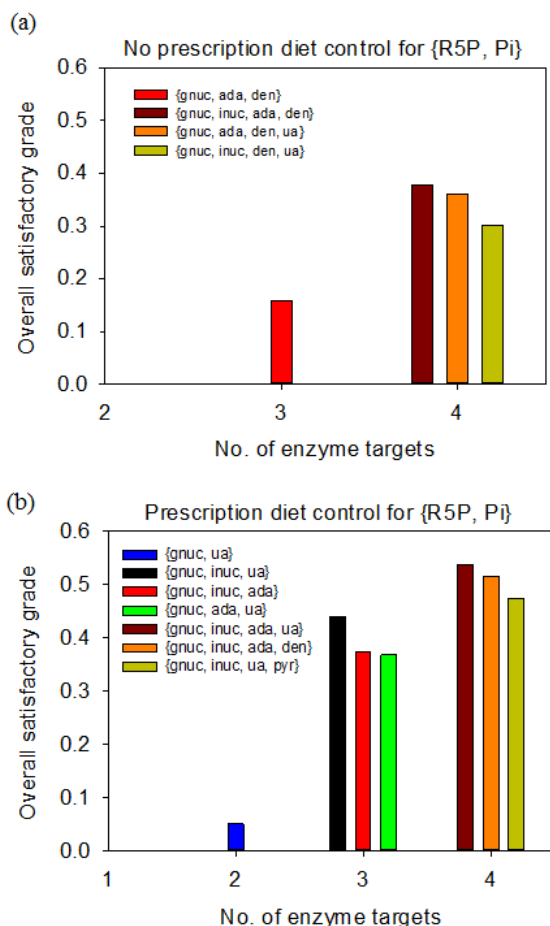

Fig. 7 The overall satisfactory grades for the treatment of disease caused by PRPPS hyperactivity and HGPRT deficiency, simultaneously

IV. CONCLUSION

The optimization of biological systems, which is a branch of metabolic engineering, has generated a lot of industrial and academic interest for a long time. The ultimate goal of this optimization is to find the optimal mutation strategy for improving productivity and to detect new target enzymes for curing metabolic diseases. This study introduces a generalized fuzzy multi-objective optimization approach to find optimal design for metabolic network systems.

REFERENCES

- [1] R. B. Bellman and L. A. Zadeh, "Decision-making in a fuzzy environment," *Management Science*, vol. 17, no. 4, pp. 141–164, 1970.
- [2] W. J. Sutherland, "The best solution," *Nature*, vol. 435, p. 569, Jun. 2005.
- [3] E. O. Voit, "Optimization in integrated biochemical systems," *Biotechnology and Bioengineering*, vol. 40, no. 5, pp. 572–582, Aug. 1992.
- [4] R. Curto, E. O. Voit, A. Sorribas, and M. Cascante, "Mathematical models of purine metabolism in man," *Mathematical Biosciences*, vol. 151, no. 1, pp. 1–49, Jul. 1998.
- [5] D. Segrè, D. Vitkup, and G. M. Church, "Analysis of optimality in natural and perturbed metabolic networks," *Proceedings of the National Academy of Sciences*, vol. 99, no. 23, pp. 15112–15117, Jun. 2002.
- [6] T. Shlomi, O. Berkman, and E. Ruppin, "Regulatory on/off minimization of metabolic flux changes after genetic perturbations," *Proceedings of the National Academy of Sciences*, vol. 102, no. 21, pp. 7695–7700, Feb. 2005.
- [7] W. H. Wu, F. S. Wang, and M. S. Chang, "Multi-objective Optimization of Enzyme Manipulations in Metabolic Networks Considering Resilience Effects," *BMC Systems Biology*, vol. 5, p. 145, Sep. 2011.
- [8] J. Vera, R. Curto, M. Cascante, and N. V. Torres, "Detection of potential enzyme targets by metabolic modelling and optimization: application to a simple enzymopathy," *Bioinformatics*, vol. 23, no. 17, pp. 2281–2289, Sep. 2007.
- [9] K. C. Hsu and F. S. Wang, "Fuzzy Optimization for Detecting Enzyme Targets of Human Uric Acid Metabolism," *Bioinformatics*, vol. 29, no. 24, pp. 3191–3198, Dec. 2013.
- [10] J. P. Chiou and F. S. Wang, "Hybrid Method of Evolution Algorithms for Static and Dynamic Optimization Problems with Application to A Fedbatch Fermentation Process," *Computers & Chemical Engineering*, vol. 23, no. 9, pp. 1277–1291, Nov. 1999.