

# Fuzzy Logic Speed Controller for Direct Vector Control of Induction Motor

Ben Hamed M., Sbita L

**Abstract**—This paper presents a new method for the implementation of a direct rotor flux control (DRFOC) of induction motor (IM) drives. It is based on the rotor flux components regulation. The d and q axis rotor flux components feed proportional integral (PI) controllers. The outputs of which are the target stator voltages ( $v_{dsref}$  and  $v_{qsref}$ ). While, the synchronous speed is depicted at the output of rotor speed controller. In order to accomplish variable speed operation, conventional PI like controller is commonly used. These controllers provide limited good performances over a wide range of operations even under ideal field oriented conditions. An alternate approach is to use the so called fuzzy logic controller. The overall investigated system is implemented using dSpace system based on digital signal processor (DSP). Simulation and experimental results have been presented for a one kw IM drives to confirm the validity of the proposed algorithms.

**Keywords**—DRFOC, fuzzy logic, variable speed drives, control, IM and real time.

## I. INTRODUCTION

IMs with squirrel cage rotors are the workhorse of industry. They are relatively cheap and robust since their construction; neither slip rings nor collectors are needed. IM can be operated directly from the mains, but variable speed and often better energy efficiency are achieved by means of a frequency converter between the mains and the IM. A frequency converter system consists of a rectifier, a voltage stiff DC link and a pulse width modulation (PWM) inverter. Despite of all advantages, compared with DC motor, IMs are more difficult in control due to their non linear dynamics [1]. The electromagnetic torque is coupled with the flux. A simple way of controlling the IMs is to adjust the magnitude of the stator voltage proportionally to a reference synchronous frequency [2-4]. The former is called a scalar control strategy. The knowledge of IM parameters is not necessary implying that the method is quite robust. However, the dynamic performances are so poor. To improve the performances of the IMs and obtain high performances at dynamic regime, a field oriented control (FOC) is early investigated [5] and more implemented in many industry applications [6-8]. The basic principle of the FOC is to keep the flux constant and oriented to the direct axis of a synchronous rotating reference frame which means that the reverse flux component is equaled to

zero value at ideal IM FOC decoupling. Based on the principle of the FOC, two FOC strategies are developed in the literature: the indirect field oriented control (IFOC) and the direct field oriented control (DFOC). The IFO controlled IM drives are widely used in high performance industry applications due to its simplicity and fast dynamic response [9]. The d and q components of the stator voltage and the synchronous speed are obtained based on the Park IM model and the field oriented control conditions. However, these variables are altered by physical phenomena such as temperature [10-12]. Therefore, any parameter mismatch in the IM parameters, specially the rotor time constant, will detrimentally affects the torque response and then the IFOC dynamic performance [13-16]. Attention is focused to force field orientation through on line estimation of machine parameters [14-17]. The on line identification and adjustment of the IM parameters increase computation time. Since, the artificial neural network (ANN) have been proved to be a universal approximation of non linear dynamic systems, it is used to achieve the IFOC implementation [18]. In this case, the data base is obtained when the IM fed with scalar control inverter for various values covering the whole range of IM flux. However, in this test, the IM parameters effects are omitted. Therefore, in practice, the obtained ANN decoupling will remain sensitive to IM parameters.

DFOC is based on the regulation of the IM flux. Different strategies are proposed in the literature [18-28]. They are based on the speed and flux magnitude regulation with or without the decoupling compensators. The slip angular frequency to align the IM flux with the d axis is computed using the Park IM model making the proposed DFOC scheme sensitive to IM parameters.

In this paper, we propose a new method to achieve the direct rotor field oriented control (DRFOC). The needed rotor flux components are reconstructed using the IM model. A fuzzy logic controller is used in speed control loop. The overall investigated system (Fig. 1) is implemented using dSpace system based on digital signal processor (DSP). Simulation and experimental results have been presented for one kw IM drives to confirm the effectiveness of the proposed drive system.

## II. MATHEMATIC MODELING OF INDUCTION MOTOR

Assuming linear magnetic circuits, equal inductances and neglecting iron losses, the mathematical model of the IM viewed from the stator reference frame is given by the following set of equations:

Ben Hamed Mouna is with the National Engineering of Gabes, Tunisia (corresponding author to provide phone: 216-75-392-100; fax: 216-75-392-190; e-mail: benhamed2209@yahoo.fr).

Sbita Lassaad is with the National Engineering of Gabes, Tunisia (e-mail: lassaad.sbita@enig.rnu.tn).

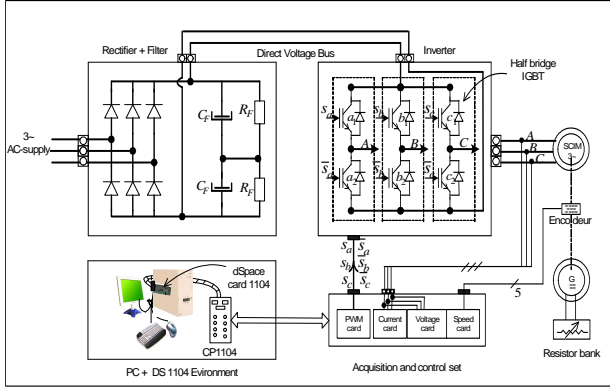

Fig. 1. The bloc diagram of the proposed induction motor drive system.

$$\frac{di_{\alpha s}}{dt} = -\left(\frac{r_s}{\sigma L_s} + \frac{1-\sigma}{\sigma \tau_r}\right) i_{\alpha s} + \frac{M}{\sigma L_s L_r \tau_r} \Phi_{\alpha r} + \frac{M \omega}{\sigma L_s L_r} \Phi_{\beta r} + \frac{1}{\sigma L_s} v_{\alpha s} \quad (1)$$

$$\frac{di_{\beta s}}{dt} = -\left(\frac{r_s}{\sigma L_s} + \frac{1-\sigma}{\sigma \tau_r}\right) i_{\beta s} - \frac{M \omega}{\sigma L_s L_r} \Phi_{\alpha r} + \frac{M}{\sigma L_s L_r \tau_r} \Phi_{\beta r} + \frac{1}{\sigma L_s} v_{\beta s} \quad (2)$$

$$\frac{d\Phi_{\alpha s}}{dt} = v_{\alpha s} - r_s i_{\alpha s} \quad (3)$$

$$\frac{d\Phi_{\beta s}}{dt} = v_{\beta s} - r_s i_{\beta s} \quad (4)$$

$$\frac{d\Phi_{\alpha r}}{dt} = \frac{M}{\tau_r} i_{\alpha s} - \frac{1}{\tau_r} \Phi_{\alpha r} - \omega \Phi_{\beta r} \quad (5)$$

$$\frac{d\Phi_{\beta r}}{dt} = \frac{M}{\tau_r} i_{\beta s} + \omega \Phi_{\beta r} - \frac{1}{\tau_r} \Phi_{\beta r} \quad (6)$$

Where  $L_s$  and  $L_r$  are the stator and rotor self inductances respectively,  $M$  is the mutual inductance,  $r_s$  is the stator resistance,  $\tau_r$  is the rotor time constant,  $\sigma$  is the motor leakage coefficient,  $\omega$  is the rotor electrical angular velocity,  $i_{\alpha s}$ ,  $i_{\beta s}$ ,  $v_{\alpha s}$  and  $v_{\beta s}$  are the stator currents and voltages components,  $\Phi_{\alpha s}$ ,  $\Phi_{\beta s}$ ,  $\Phi_{\alpha r}$  and  $\Phi_{\beta r}$  are the stator and rotor fluxes components respectively.

The electromagnetic torque equation and the electrical angular speed are related by

$$J \frac{d\omega}{dt} = P (T_e - T_L - f \omega) \quad (7)$$

In (7),  $J$  is the moment of inertia of the IM,  $f$  is the friction constant,  $T_e$  and  $T_L$  are the electromagnetic and load torques respectively and  $P$  is the number of pair poles.

### III. PROPOSED DRFOC SCHEME FOR INDUCTION MOTOR DRIVES

Based on the dynamic IM model represented according to the usual d and q axis components in a synchronous rotating

frame, the d and q rotor flux components can be written as

$$\Phi_{dr} = \frac{\frac{M}{r_s}}{1 + [\tau_r + \tau_s \sigma + L_r L_s] s + \tau_r \tau_s s^2} v_{ds} + E_d \quad (8)$$

$$\Phi_{qr} = \frac{\frac{M}{r_s}}{1 + [\tau_r + \tau_s \sigma + L_r L_s] s + \tau_r \tau_s s^2} v_{qs} + E_q \quad (9)$$

and its synchronous speed is given as

$$\omega = \omega_s + \omega_{sl} \quad (10)$$

The coupling terms  $E_d$  and  $E_q$  are expressed with

$$E_d = \frac{-2\omega_s \tau_r - \tau_r \omega_s + \omega_s \left( \frac{M^2}{r_s r_s} - \tau_r \tau_s - \tau_r \tau_s \sigma \right) s \Phi_{qr} + \left( \frac{M^2}{r_s r_s} - \tau_r \tau_s \right) \omega_s \omega_s \Phi_{dr}}{1 + [\tau_r + \tau_s \sigma + L_r L_s] s + \tau_r \tau_s s^2}$$

and

$$E_q = \frac{\omega_s \tau_r + \tau_r \omega_s + \left( \tau_r \omega_s + \frac{\tau_r \sigma}{r_s} \omega_s - \frac{\omega_s}{r_s r_s} \right) s \Phi_{dr} + \left( \frac{1}{r_s r_s} - \tau_r \tau_s \right) \omega_s \omega_s \Phi_{qr}}{1 + [\tau_r + \tau_s \sigma + L_r L_s] s + \tau_r \tau_s s^2}$$

Here,  $\omega_r$  and  $\tau_s$  are the slip speed and the stator time constant.

It can be seen from (1) that it is possible to control the d and q fluxes separately if the coupling terms  $E_d$  and  $E_q$  are equaled to zero on one hand. On the other hand, it is shown from (2) that the rotor speed is controlled with the synchronous speed if the slip speed, imposed with the load torque, is equaled to zero. Therefore, a d, q stator flux components and speed controllers are to be used to attenuate the effect of the decoupling disturbances and load torque appliance.

The new decoupling method needs the rotor flux components. As it is well known that the rotor flux is unmeasured. Therefore, in this paper, it is reconstructed based on the dynamic IM model.

$$\frac{d\Phi_{\alpha re}}{dt} = \frac{M}{\tau_r} i_{\alpha se} - \frac{1}{\tau_r} \Phi_{\alpha re} - \omega \Phi_{\beta re} \quad (11)$$

$$\frac{d\Phi_{\beta re}}{dt} = \frac{M}{\tau_r} i_{\beta se} + \omega \Phi_{\beta re} - \frac{1}{\tau_r} \Phi_{\beta re} \quad (12)$$

Here "e" denotes the estimated value.

### IV. SPEED AND ROTOR FLUX COMPONENTS CONTROLLERS DESIGN

#### A. Fuzzy logic speed controller

Fig. 2 shows the block diagram of a fuzzy logic speed controller where the speed error  $e$  and its rate of change  $Ce$  are the input variables;  $ne$ ,  $nCe$  and  $G$  are inputs and outputs scaling gains. The basic fuzzy logic controller block is composed of fuzzification interface, fuzzy rules and inference mechanism and defuzzification interface. The input/output variables used in this paper are fuzzified by seven symmetrical and triangular membership functions (MFs) (Fig. 3(a), (b) and (c)) normalized in the universe of discourse between -1 and +1. The MFs are labeled as follows: NB—negative big, NM—negative medium, NS—negative small, ZE—zero equal, PS—positive small, PM—positive medium and PB—positive big.

The MFs of adjacent fuzzy sets are complementary in the sense that the sum of membership values is one at all times. The shape of these MFs reduces the computation burden of the controller. The center of gravity is used to compute the output signal. The associated fuzzy rule matrices of main fuzzy logic controller are given in table I. These rules were designed based on the dynamic behavior of the error signal resulting in the symmetrical matrix.

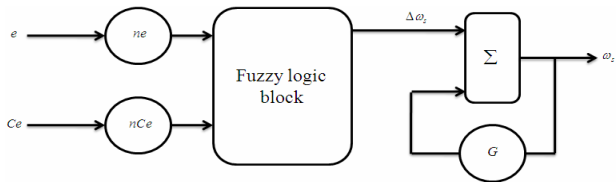
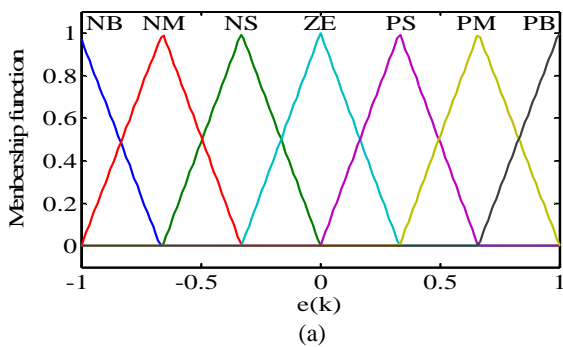
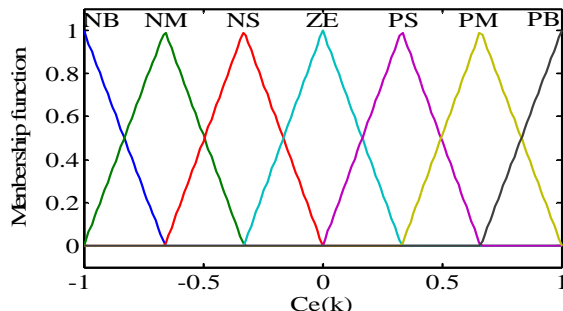

Fig. 2. Structure of fuzzy controller



(a)



(b)

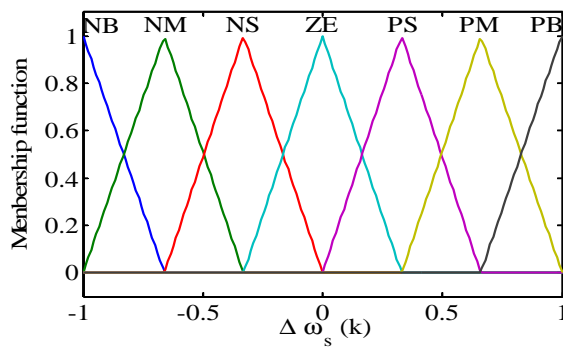

(c)

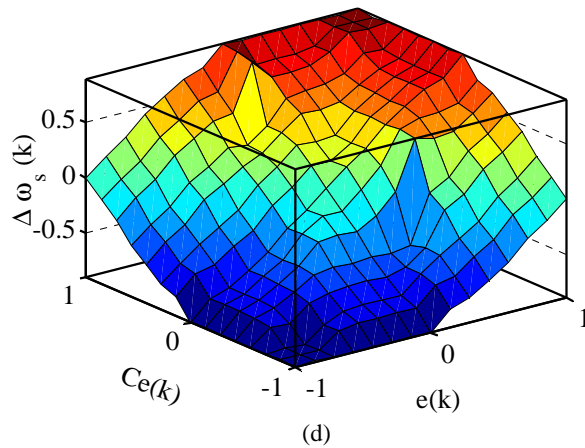

(d)

Fig. 3. The memberships of the: a - Error, b - Error variation, c - Command variation, d - Control surface.

TABLE I  
RULE MATRIX FOR FUZZY LOGIC SPEED CONTROLLER

e Ce	NB	NM	NS	ZE	PS	PM	PB
NB	NM	NS	ZE	PS	PM	PB	PS
NM	NS	ZE	PS	PS	PM	PB	PM
NS	ZE	PS	PM	PB	PB	PB	ZE
ZE	NB	NM	NS	ZE	PS	PM	PB
PS	NM	NS	ZE	PS	PS	PM	PB
PM	NS	ZE	PS	PM	PM	PM	PB
PB	ZE	PS	PM	PB	PB	PB	PB

*B. PI rotor flux components controllers*

It can be seen that the d axis and q axis voltage equations are coupled by the terms  $E_d$  and  $E_q$ . These terms are considered as disturbances and are cancelled by using the proposed decoupling method. If the decoupling method is implemented, the flux components equations become

$$\Phi_{dr} = G(s)v_{ds} \tag{13}$$

$$\Phi_{dq} = G(s)v_{dq} \tag{14}$$

Thus, the dynamics of the d axis and q axis are now represented by simple linear second order differential equations. Therefore, it is possible to effectively control the flux components with a PI controller.

If we assume that the  $E_d$  and  $E_q$  are cancelled by the proposed decoupling method, the transfer function of the d axis flux component is expressed as

$$\frac{\Phi_{dr}}{v_{ds}} = G(s) = \frac{M}{r_s} \frac{1}{1 + [\tau_r + \tau_s \sigma + L_r L_s]s + \tau_r \tau_s s^2} \tag{15}$$

The numerical application leads to

$$G(s) = \frac{58.8}{(s + 1.8)[s + 227.8]} \tag{16}$$

The open loop flux transfer function with the PI controller is then expressed as

$$G_{BO}(s) = \frac{k_p}{s} \left( s + \frac{k_i}{k_p} \right) \frac{58.8}{(s+1.8)[s+227.8]} \quad (17)$$

The pole dominant pole compensation method leads to

$$F_{BO}(s) = \frac{58.8k_p}{[s^2 + 227.8s]} \quad (18)$$

Then, the closed loop transfer function is reduced to

$$F_{TRF}(s) = \frac{\Phi_{dr}}{\Phi_{dref}} = \frac{58.8k_p}{s^2 + 227.8s + 58.8k_p} \quad (19)$$

admitting the following characteristic equation

$$s^2 + 227.8s + 58.8k_p = 0 \quad (20)$$

The last one is to be identified to a desired characteristic equation defined as

$$s^2 + 2\xi_d \omega_{nd} s + \omega_{nd}^2 = 0 \quad (21)$$

Finally, the PI controller parameters are defined as

$$k_i = 1.8k_p \quad (22)$$

$$k_p = \frac{\omega_{nd}^2}{58.8} \quad (23)$$

Where  $\omega_{nd}$  and  $\xi_d$  denote the natural frequency and damping ratio respectively  $k_p$  and  $k_i$  are the proportional and integral gains of the PI controller.

As the dynamics of the d and q axis rotor flux components are equivalent, the PI gains can be copied to the q axis controller.

V.SIMULATION AND EXPERIMENTAL RESULTS

The laboratory prototype used to verify the behavior of the proposed DRFOC with fuzzy logic speed controller is shown in Fig. 4.



Fig. 4. A photo of the experimental set up.

It consists of dSpace system with DS1104 controller board based on digital signal processor (DSP) TMS320F240 with its connector panel, control PC and a DC machine mechanically coupled to IM. The switched load resistor box is used to change the loading of the IM. A three phase Insulated Gate Bipolar Transistor (IGBT) inverter is used as power stage with a full controlled rectifier. The IM stator currents and voltages are measured by LEM sensors and processed by 16-b A/D

converters. An incremental encoder position sensor delivering 1024 pulses per revolution is mounted on the rotor shaft of the IM. The pulse width modulation to control the power modules are generated by dSpace system.

The fuzzy logic speed controller, decoupling method and flux estimation algorithms are implemented in Matlab/Simulink with the help of the Real Time Interface (RTI) provided by dSpace system (Fig. 5). The used sampling period of 100µs is selected based on the actual computation of the implemented algorithms. A suitable virtual instrument has also been developed to manage an on line all required electrical and mechanical signals of the IM.

Experiments were carried out on various operating conditions to highlight the performance of the proposed algorithms. Some selected simulation and experimental results are presented here. In Figs. 6 and 7, actual rotor speed, synchronous speed and rotor flux trajectory are presented for variable target rotor speed at no load torque. It can be noted how the measured speed tracks accurately the target signal both in simulation and in experimentation, especially at steady state on one hand. On other hand, it can be seen from these results that the decoupling of IM motor is established as the rotor flux follows a circular trajectory both in simulation and in experimentation.

Investigating the ability of the drive to reject load disturbances, the drive is initially operated at 1000rpm. A sudden step increase of 50% rated load torque is applied at 28s and then removed at 36s. The obtained responses are shown in Figs. 8 and 9 as it is given in Figs. 8(a) and 9(a) the controlled speed coincides with the target speed despite of external disturbances. In addition, the rotor flux trajectory follows a circular one expected at loading and unloading conditions where a tiny error appeared and thanks to the used controllers, this error despaired, proving the robustness speed controller and decoupling method against external disturbances. Note that during implementation, the loading of the motor was accomplished through the DC generator using the load box switches. Consequently, the simulated loading behaviors of the drive are slightly different than the implemented one.

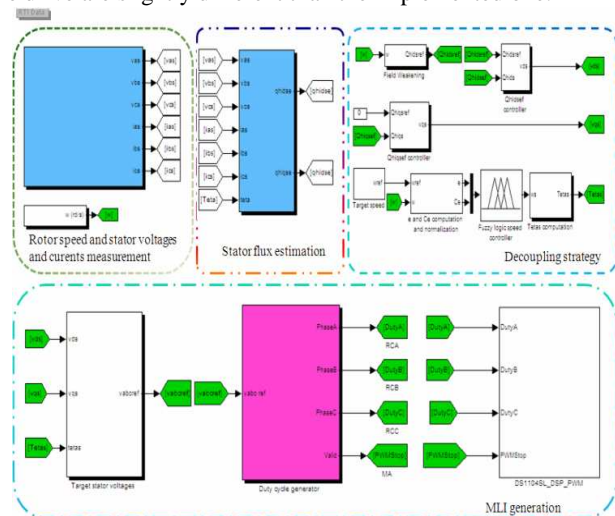
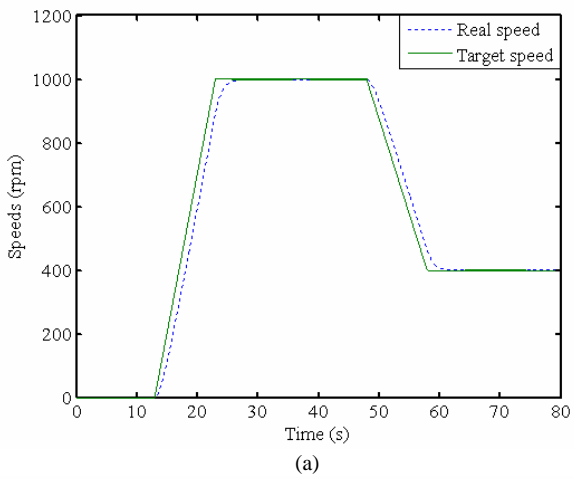
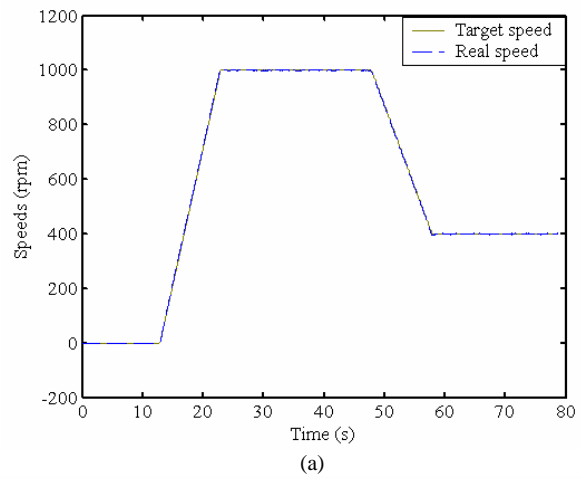

Fig. 5. A photo of the experimental set up.



(a)



(a)

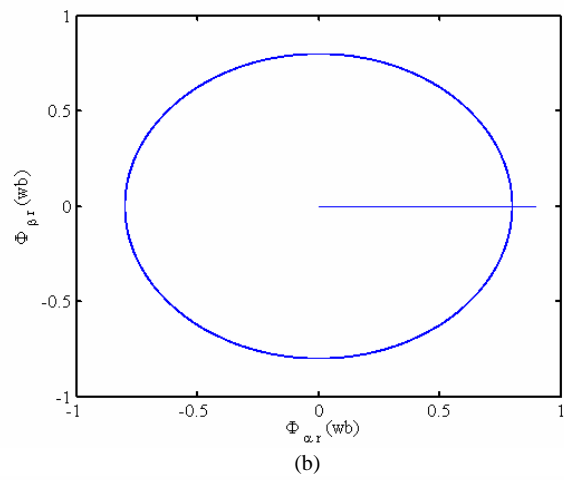

(b)

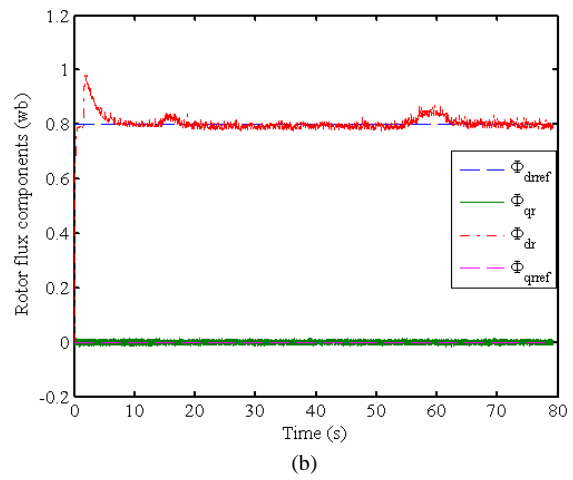

(b)

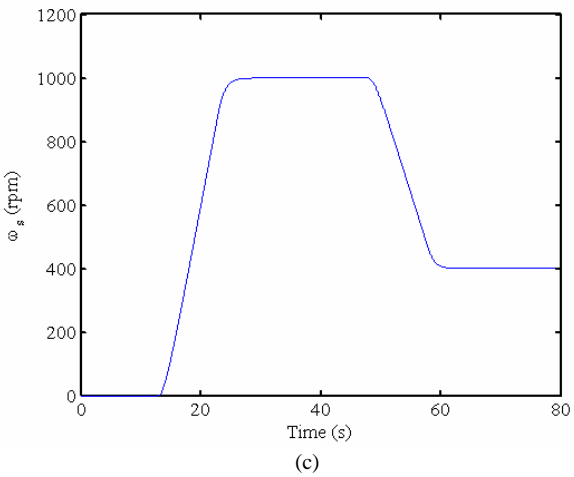

(c)

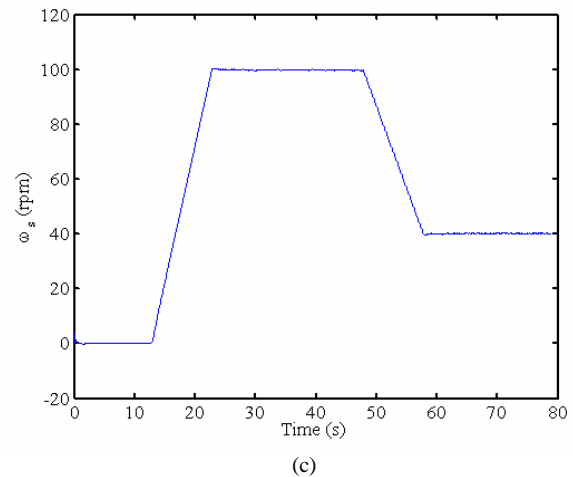

(c)

Fig. 6. Simulation results for variable target speed under no load appliance: (a) real and target speeds, (b) rotor flux trajectory and (c) synchronous speed.

Fig. 7. Experimental results for variable target speed under no load appliance: (a) real and target speeds, (b) rotor flux trajectory and (c) synchronous speed.

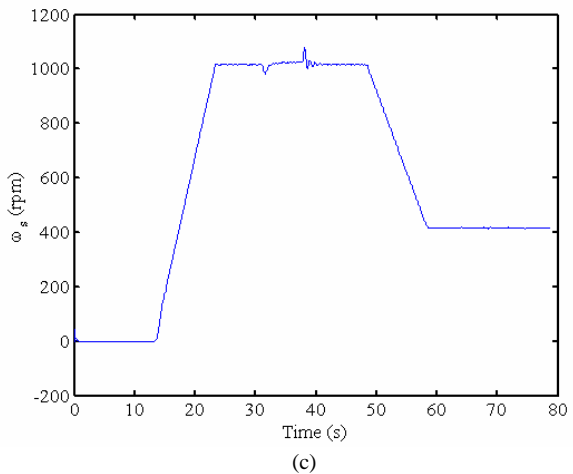
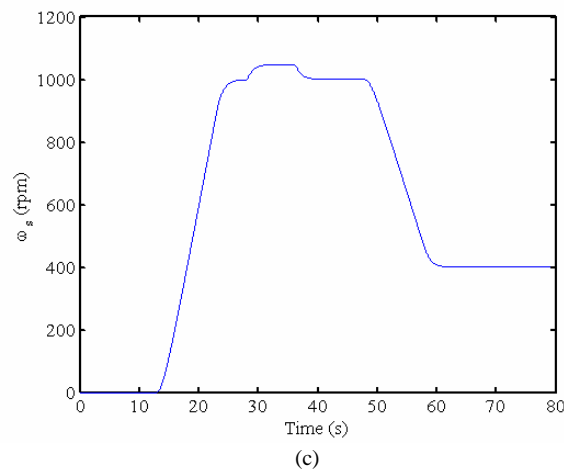
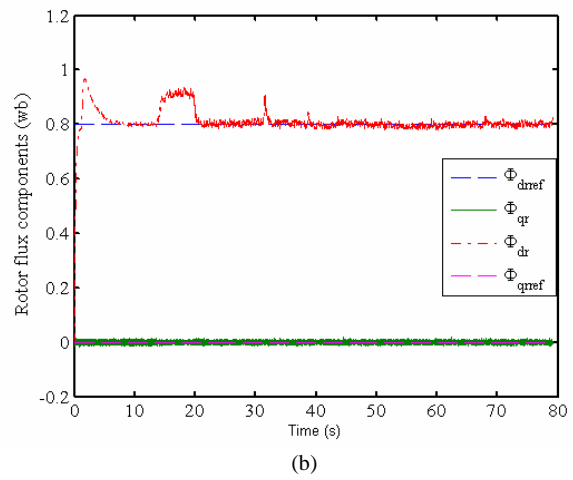
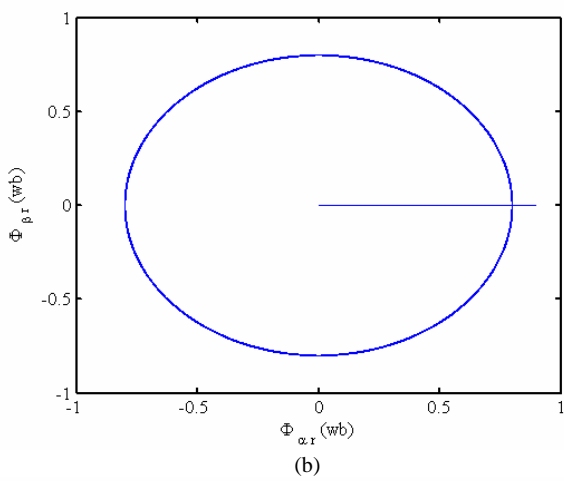
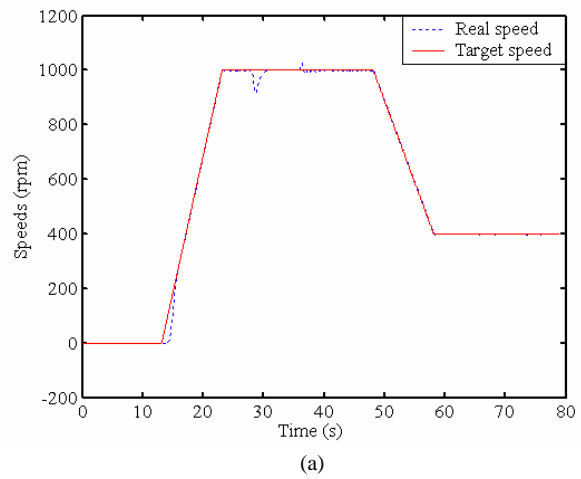
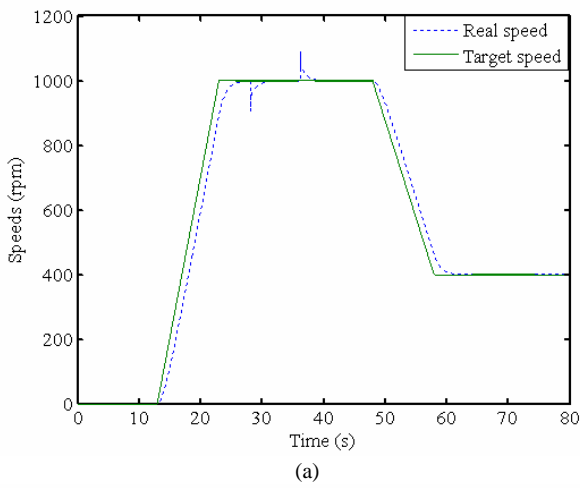

Fig. 8. Simulation results for variable target speed under load appliance: (a) real and target speeds, (b) rotor flux trajectory and (c) synchronous speed.

Fig. 9. Experimental results for variable target speed under load appliance: (a) real and target speeds, (b) rotor flux trajectory and (c) synchronous speed.

## VI. CONCLUSION

This paper has described the design, simulation and test of a simple but effective fuzzy logic controller for DRFOC of IM drives. Through a series of simulations and experimental results, the speed tracking and disturbance rejection capabilities of the controller were verified. Besides, the proposed DRFOC scheme shows good dynamic performances.

All high performances of DRFOC IM drives require accurate rotor flux components. In this paper, they are reconstructed using the IM model. The later is IM parameters depended. However, these parameters are altered especially with temperature. To improve the performance of the overall drive system, a robust rotor flux estimation algorithm is to be investigated. This will be the subject of future follow up work.

## REFERENCES

- [1] A. Rubaai, M. J. Castro Sitiriche and A. R. Ofofi, "DSP based laboratory implementation of hybrid fuzzy PID controller using genetic optimization for high performance motor drives", *IEEE Trans. On Industry Applications*, vol. 44, pp. 1977–1986, Nov./Dec. 2008.
- [2] L. Sbïta, *Contribution in digital control of systems: Application to digital control of sensorless induction motor drive*, dissertation of HDR. National Engineering School of Sfax, Tunisia, Mar. 2008, p. 153.
- [3] M. Ben Hamed, "Contribution à la commande numérique et synthèse multi algorithmique d'observation de flux et de la vitesse d'un actionneur à induction". PhD. Dissertation, Electrical Dep., Université of Gabès Tunisia, Mar. 2009.
- [4] X. Dong and al., "Fuzzy-logic-based V/f control of an induction motor for a DC grid power-leveling system using flywheel energy storage equipment", *IEEE Trans. on Industry Electronics*, vol. 56, pp. 3161–3168, Aug. 2009.
- [5] F. Blaschke, "The principle of field orientation applied to the transvector closed loop control system for rotating field machines", *Siemens Rev.*, vol. 34, pp. 217–220, May. 1972.
- [6] N. Sliatore and al., "Optimization of delayed state kalman filter based algorithm via differential evolution for sensorless control of induction motors", *IEEE Trans. On Industry Electronics*, vol. 57, pp. 385–394, Jan. 2010.
- [7] S. M. Gadoue, D. Giaouris and J. W. Finch., "MRAS sensorless vector control of an induction motor using new sliding-mode and fuzzy-logic adaptation", *IEEE Trans. on Energy Conversion*, vol. 99, pp. 1–9, Dec. 2009.
- [8] H. K. Khalil, E.G. Strangas, S. Jurkovic., "Speed observer and reduced nonlinear model for sensorless control of induction motors", *IEEE Trans. On Control. System Technology*, vol. 17, pp. 327–339, Mar. 2009.
- [9] M. Missiala and al., "Fuzzy self-tuning speed control of an indirect field-oriented control induction motor drive", *IEEE Trans. On Industry Applications*, vol. 44, pp. 1732–1740, Nov./Dec. 2008.
- [10] A. Boglietti, A. Cavagnino and D. Staton., "Determination of critical parameters in electrical machine thermal models", *IEEE Trans. On Industry Applications*, vol. 44, pp. 1150–1159, Jul./Aug. 2008.
- [11] K. Rae and J. Kiseok, "Induction motor rotor temperature estimation based on a high-frequency model of a rotor bar", *IEEE Trans. On Industry Applications*, vol. 45, no. 4, pp. 1267–1275, Jul. 2009.
- [12] Z. Gao and al., "A sensorless adaptive stator winding temperature estimator for mains fed induction machines with continuous operation periodic duty cycles", *IEEE Trans. On Industry Applications*, vol. 44, pp. 1533–1534, Sept./Oct. 2008.
- [13] C. Lascu., I. Boldea and F. Blaabjerg., "Class of speed-sensorless sliding-mode observers for high-performance induction motor drives", *IEEE Trans. On Industry Electronics*, vol. 56, pp. 3394–3403, Sept. 2009.
- [14] S. Maiti and al., "Model reference adaptive controller based rotor resistance and speed estimation techniques for vector induction motor drive utilizing reactive power", *IEEE Trans. on Industry Electronics*, vol. 55, pp. 594–601, Feb. 2008.
- [15] M. S. Zaky and al., "Wide-speed-range estimation with online parameter identification schemes of sensorless induction motor drives", *IEEE Trans. On Industry Electronics*, vol. 56, pp. 4035–4042, Oct. 2009.
- [16] S. Hasan and I. Husain., "A Luenberger–sliding mode observer for online parameter estimation and adaptation in high-performance induction motor drives", *IEEE Trans. on Industry Applications*, vol. 45, pp. 772–781, Mar./Apr. 2009.
- [17] K. Szabut, T. Orłowska Kowalska and M. Dybkowski., "Indirect adaptive control of induction motor drive system with an elastic coupling", *IEEE Trans. on Industry Electronics*, vol. 56, pp. 4035–4042, Oct. 2009.
- [18] S. Rao, M. Buss and S. Utkin, "Simultaneous state and parameter estimation in induction motors using first and second order sliding modes", *IEEE Trans. On Industry Electronics*, vol. 57, pp. 3369–3376, Sept. 2009.
- [19] S. M. Gadoue, D. Giouris and J. W. Finch, "Sensorless control of induction motor drives at very low and zero speeds using neural network flux observers", *IEEE Trans. On Industry Electronics*, vol. 56, pp. 3029–3039, Aug. 2009.
- [20] A. Ba Razzouk and al., "Field oriented control of induction motors using neural networks decouplers", *IEEE Trans. On Industry Power Electronics*, vol. 12, pp. 752–763, Jul. 1997.
- [21] M. Comanescu., "An Induction-motor speed estimator based on integral sliding-mode current control", *IEEE Trans. On Industry Electronics*, vol. 56, pp. 3414–3423, Sept. 2009.
- [22] A. Trentin and al., "Optimized commissioning method for enhanced vector control of high-power induction motor drives", *IEEE Trans. On Industry Electronics*, vol. 56, pp. 1708–1717, Apr. 2009.
- [23] B. Verselic and al., "High performance position control of induction motor using discrete time sliding mode control", *IEEE Trans. Ind. Electron.*, vol. 55, pp. 3809–3817, Oct. 2008.
- [24] E. S. de Santana and al., "A predictive algorithm for controlling speed and rotor flux of induction motor", *IEEE Trans. On Industry Electronics*, vol. 55, pp. 4398–4407, Oct. 2008.
- [25] A. Consoli and al., "Flux and voltage calculations of induction motors supplied by low- and high-frequency currents", *IEEE Trans. Ind. Applicat.*, vol. 45, no. 2, pp. 737–746, Mar. 2009.
- [26] M. Ghanes and Z. Gang, "On sensorless induction motor drive sliding mode observer and output feedback controller", *IEEE Trans. Ind. Electron.*, vol. 56, pp. 3404–3413, Sept. 2009.
- [27] S. M. A. Cruz. and al., "A New model-based technique for the diagnosis of rotor faults in RFOC induction motor drives", *IEEE Trans. Ind. Electron.*, vol. 55, pp. 4218–4228, Dec. 2008.
- [28] T. S. Kwon, M. H. Shin and D. S. Hyun., "Adaptive fuzzy control of nonlinear systems in pure feedback form based on input-to-state stability", *IEEE Trans. Fuzzy Sys.*, vol. 18, pp. 80 - 93, Feb. 2010.

**Mouna Ben Hamed** obtained the Master degree on September 22 2006 in and PhD degree on Marsh 04 2009 in automatic and intelligent techniques from National engineering School of Gabès. She works actually as an associate professor at the High Institute of Industrial Systems of Gabès (ISSIG) of Gabès -Tunisia. Her fields of interest include power electronics, machine drives, automatic control, modeling, observation, identification, fault detection, localization and Isolation and embedded systems.

**Lassaâd Sbïta** obtained the doctorate thesis on July 1997 in Electrical engineering from ESSTT of Tunis, Tunisia. He works as Professor at the electrical-automatic genius department of the National Engineering School of Gabès, Tunisia. He received the "Habilitation de Diriger des Recherches" (HDR) from the National Engineering School of Sfax, Tunisia in Marsh 08 2008. His fields of interest include power electronics, machine drives, automatic control, modeling, observation and identification.