

# Fractional-Order Modeling of GaN High Electron Mobility Transistors for Switching Applications

Anwar H. Jarndal, Ahmed S. Elwakil

**Abstract**—In this paper, a fraction-order model for pad parasitic effect of GaN HEMT on Si substrate is developed and validated. Open de-embedding structure is used to characterize and de-embed substrate loading parasitic effects. Unbiased device measurements are implemented to extract parasitic inductances and resistances. The model shows very good simulation for S-parameter measurements under different bias conditions. It has been found that this approach can improve the simulation of intrinsic part of the transistor, which is very important for small- and large-signal modeling process.

**Keywords**—Fractional-order modeling, GaN HEMT, Si-substrate, open de-embedding structure.

## I. INTRODUCTION

NOWADAYS, GaN HEMT (high electron mobility transistor) has proven to be an outstanding device for high frequency and high power applications. This device is typically built on SiC-substrate, which has excellent thermal characteristics and provides higher lattice and thermal matching [1]. To reduce its cost and improve its integration capability, this device is also currently fabricated on Si substrate [2]. With respect to the SiC-substrate, there are some challenges including the lattice mismatch between GaN and Si ( $\approx 17\%$ ) [3], which results in higher density of dislocation in the GaN-substrate interface. These dislocations manifest themselves as electron or hole traps [4], which are responsible for trapping induced memory effect under large-signal of operation [5]. These charges also cause parasitic conduction through the Si-substrate, which has lower resistivity than the SiC-substrate [6]. This substrate loading effect appears as a mixed conductive and reactive behavior in the measured Y-parameters of open structure of GaN HEMT on Si-substrate, as shown in Fig. 1. RC networks have been used to model and de-embed the parasitic effects of the gate and drain pad connections of GaN HEMT [7]. In this paper, another technique based on fractional-order element modeling is applied, validated and compared with the previous approach in [7]. One of the main advantages of fractional-order modeling with respect to the integer-order modeling is the compact and wide frequency range capabilities of the model. In particular, fractional-order models make use of a generalized capacitor element known as the Fractional-Order Capacitor (FOC) or Constant Phase Element (CPE). This element has an impedance given by  $Z = 1/Q(j\omega)^\alpha$ , where  $Q$  is known as the

pseudo-capacitance and  $\alpha$  is the dispersion coefficient [8]. For ideal capacitive behavior, without dispersion,  $\alpha=1$  and the pseudo-capacitance  $Q$  in this case is equal to the capacitance  $C$  measured in *Farad*. Note that  $Q$  does not have the exact unit of *Farad*; and hence the notation “pseudo-capacitance” is used instead of normal capacitor. Note also that the current-voltage phase angle in this device is given by  $-\alpha\pi/2$  and equals  $-\pi/2$  only for ideal capacitive behavior. The phase angle  $-\alpha\pi/2$  is constant, however it does not imply orthogonal voltage and current vectors. FOCs (CPEs) have been used in the modeling of biological tissues and particularly for bio-impedance measurements [9] and have also been extensively used for electro-chemical material characterization [10]. A special FOC is the Warburg element  $W$  [8] with an impedance given by  $Z_w = A/\sqrt{j\omega}$ . The magnitude of this impedance is  $|Z_w| = A/\sqrt{\omega}$  and its phase angle is  $-45^\circ$ . Note that  $A$  has the units of  $\Omega \cdot \sqrt{\text{rad}/\text{sec}}$ .

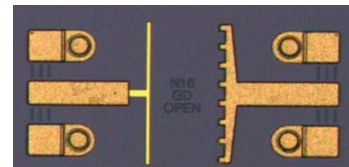

(a)

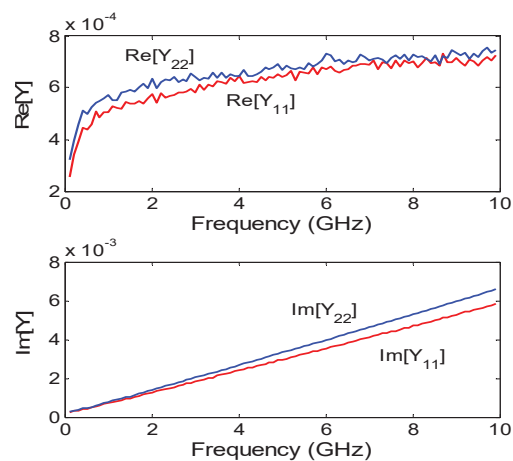

(b)

Fig. 1 (a) A photograph of open structure for a 200x16 $\mu\text{m}$  GaN HEMT on Si-substrate and (b) its measured Y-parameters

Anwar Jarndal and Ahmed S. Elwakil are with the Department of Electrical and Computer Engineering, University of Sharjah, PO 27272, Sharjah, UAE (e-mail: ajarndal@sharjah.ac.ae, elwakil@ieec.org).

As it will be shown in Section II, the Warburg element; in association with other classical integer-order circuit elements,

was found to provide a better model that fits the measured two-port impedance data.

II. GAN HEMT EQUIVALENT CIRCUIT MODEL

The small-signal equivalent circuit model, shown in Fig. 2, has been used to simulate the small signal characteristics of the depletion-type on-wafer GaN HEMT on silicon substrate [11]. Resistors  $R_g$ ,  $R_d$ , and  $R_s$  represent contact and semiconductor bulk resistances; while  $L_g$ ,  $L_d$ , and  $L_s$  model the effects of metallization inductances. In the drain and gate extrinsic parts of this model, the R-W-C networks are proposed to account for parasitic effects due to the pad connections.

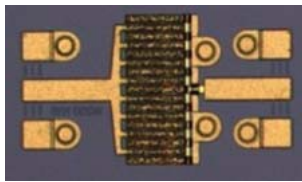

(a)

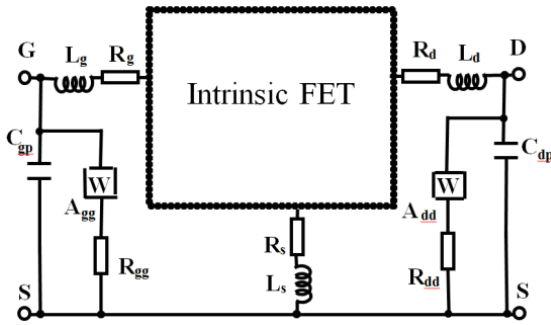

(b)

Fig. 2 (a) A photograph of 200x16µm GaN HEMT on Si Substrate and (b) its proposed equivalent circuit model

In particular, while  $C_{pd}$  and  $C_{pg}$  account for the typical pad-connection capacitances, taking into account the significant substrate loading effect of the device, shunt fractional-order circuits are added to simulate this extra parasitic effect. The circuits include  $R_{gg}$  and  $A_{gg}$  (respectively  $R_{dd}$  and  $A_{dd}$ ) which describe the parasitic conduction and fringing capacitance between gate and source (respectively drain and source) electrodes via the substrate.  $A_{gg}$  and  $A_{dd}$  are the Warburg elements (diffusion elements) values.

The open structure in Fig. 1 (a) is modelled by the proposed equivalent circuit in Fig. 3. The circuit element values are extracted by fitting 10 GHz measured Z-parameters of the structure using a nonlinear least squares optimization technique. Fitting the measured data to this model yields the results given in Table I. The values of these elements have been estimated with less than 2.5% absolute error. Figs. 4 and 5 show the fitted real and imaginary parts of  $Z_{11}$  and  $Z_{22}$  to the measured data. These results are also compared in the same figures with the Z-parameters simulation using the model

reported in [7]. The proposed model shows better fitting especially in the low frequency range.

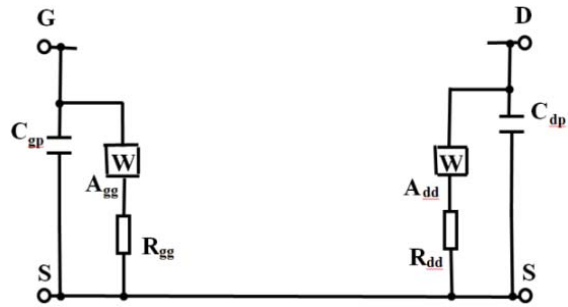

Fig. 3 Equivalent circuit model for the open structure in Fig. 1 (a)

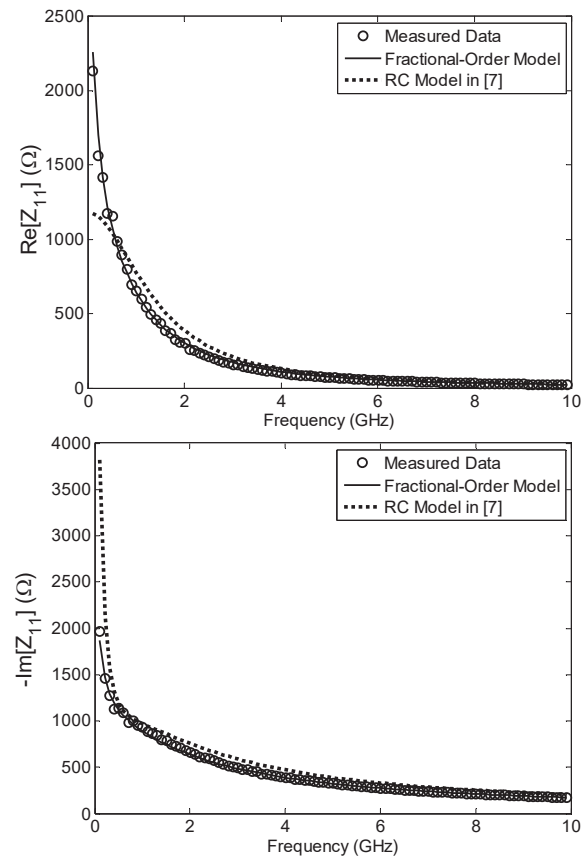

Fig. 4 Measured and simulated  $Z_{11}$  of open structure for a 200x16µm GaN HEMT on Si-substrate

TABLE I  
EXTRACTED PARAMETERS OF OPEN DE-EMBEDDING STRUCTURE CIRCUIT OF A 200X16µM GAN HEMT ON SI-SUBSTRATE

$C_{gg}$ (pF)	$C_{dd}$ (pF)	$R_{gg}$ (Ω)	$R_{dd}$ (Ω)	$A_{gg}$ ( $M\Omega \cdot \sqrt{rad/sec}$ )	$A_{dd}$ ( $M\Omega \cdot \sqrt{rad/sec}$ )
0.09	0.10	1154	1169	1.383	1.053

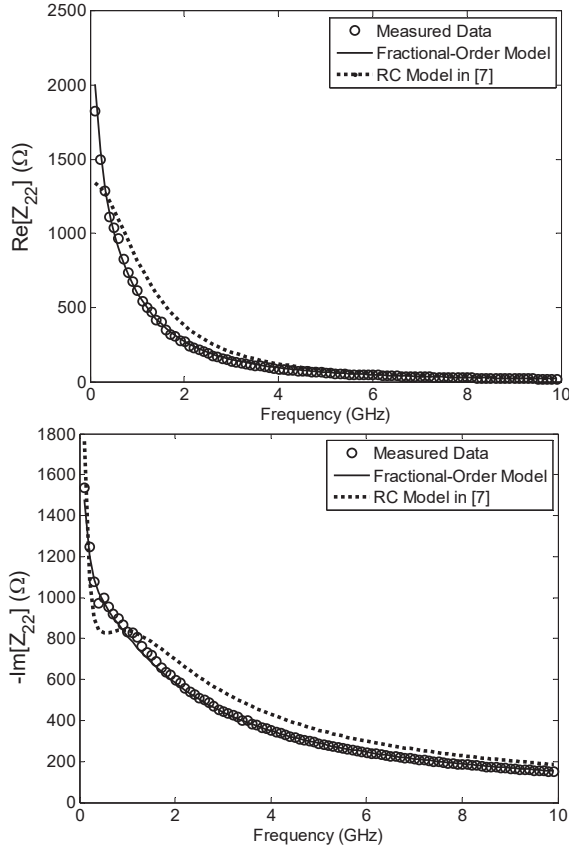

Fig. 5 Measured and simulated  $Z_{22}$  of open structure for a  $200 \times 16 \mu\text{m}$  GaN HEMT on Si-substrate

### III. UNBIASED GAN HEMT EQUIVALENT CIRCUIT MODEL

For depletion-type FET such as our device, under  $V_{DS} = 0$  V and  $V_{GS} = 0$  V, the device is at triode (ohmic) mode of operation. The intrinsic part of the device at this condition can be represented by the equivalent circuit in Fig. 6 [13]. The measured S-parameters of the device under this unbiased condition are converted to Y-parameters. Then  $Y_{11}$  and  $Y_{22}$  of the open structure are subtracted from the Y-parameters of the device to remove the substrate loading effect. These de-embedded Y-parameters are then converted to Z-parameters that can be expressed as

$$Z_{11} = R_g + R_s + \frac{1}{2}R_{ch} + \frac{R_{dy}}{1 + \omega^2 C_g^2 R_{dy}^2} + j\omega(L_g + L_s) - j \frac{\omega C_g R_{dy}^2}{1 + \omega^2 C_g^2 R_{dy}^2} \quad (1)$$

$$Z_{22} = R_d + R_s + R_{ch} + j\omega(L_d + L_s) \quad (2)$$

$$Z_{12} = Z_{21} = R_s + \frac{1}{2}R_{ch} + j\omega L_s \quad (3)$$

At high frequency,  $Z_{11}$  can be approximated by:

$$Z_{11} = R_g + R_s + \frac{1}{2}R_{ch} + \frac{1}{\omega^2 C_g^2 R_{dy}^2} + j\omega(L_g + L_s) - j \frac{1}{\omega C_g} \quad (4)$$

Thus, the inductances are extracted from the slopes of the curves for the imaginary part of Z-parameters ( $\omega \text{Im}[Z_{ij}]$ ) versus  $\omega^2$  by linear fitting (see Fig. 7 (a)). Ignoring  $R_{ch}$ , initial values for the extrinsic resistances  $R_g$ ,  $R_d$  and  $R_s$  can be extracted from the real parts of the Z-parameters ( $\text{Re}[Z_{ij}]$ ). However, the residual capacitive effect represented by  $1/\omega^2 C_g^2 R_{dy}^2$  produces nonlinear frequency dependence in the curves of the  $\text{Re}[Z_{ij}]$ . This effect can be reduced by multiplying these parameters by  $\omega^2$  and the thus resistances can be extracted from the slopes of  $\omega^2 \text{Re}[Z_{ij}]$  versus  $\omega^2$  as it is presented in Fig. 7 (b). The extracted values of the inductances and resistances are listed in Table II.

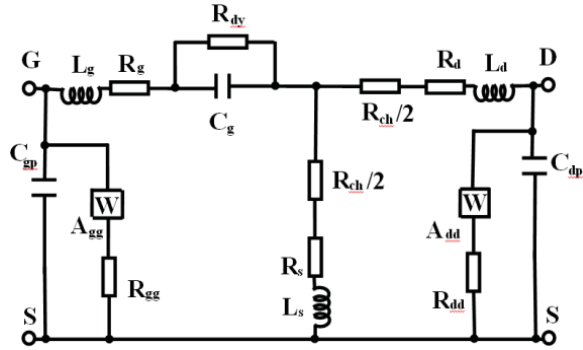
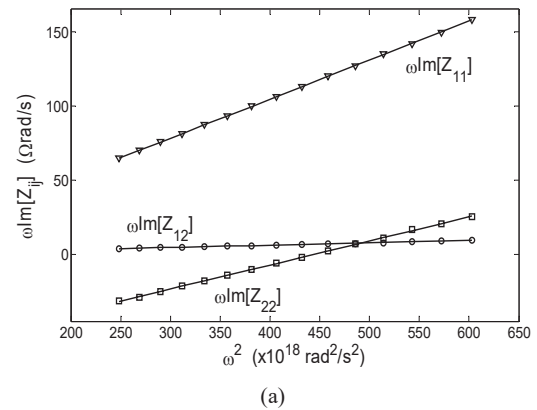
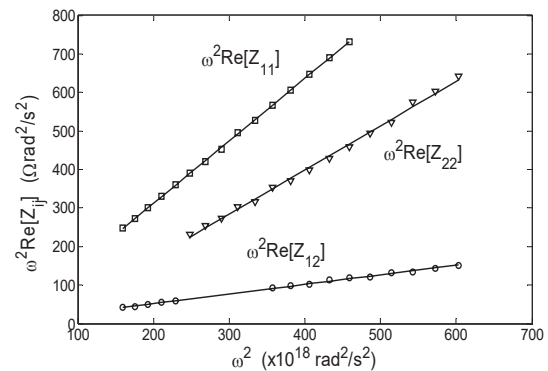

Fig. 6 Cold unbiased equivalent circuit of GaN HEMT on Si substrate



(a)



(b)

Fig. 7 (a) Inductance and (b) resistance extraction from unbiased Z-parameters of 3.2-mm GaN HEMT at  $V_{GS} = 0$  V and  $V_{DS} = 0$  V

To use GaN HEMT as a switch, the model should accurately simulate the device behavior at two extreme cases of the gate voltage. The OFF state, which can be implemented by  $V_{GS} \leq V_p$  (pinch-off voltage); while the ON state that can be implemented by  $V_{GS} = 0V$  for the considered depletion type device.

TABLE II  
EXTRACTED VALUES FOR THE EXTRINSIC INDUCTANCES AND RESISTANCES  
OF A 200X16 $\mu$ M GAN HEMT ON SI SUBSTRATE

$L_g$ (pH)	$L_d$ (pH)	$L_s$ (pH)	$R_g$ ( $\Omega$ )	$R_d$ ( $\Omega$ )	$R_s$ ( $\Omega$ )
170.7	196.2	13.7	0.87	0.94	0.35

#### IV. PINCH-OFF GAN HEMT EQUIVALENT CIRCUIT MODEL

Under cold pinch-off ( $V_{DS} = 0V$  and  $V_{GS} < V_p$ ) GaN HEMT can be simulated by the equivalent circuit model in Fig. 8 [12]. Under this condition, the intrinsic conductive elements have negligible effect and thus the intrinsic FET could be represented by a capacitive  $\pi$ -network (see Fig. 8).  $C_{gs}$  and  $C_{gd}$  describe the depletion region capacitance; while  $C_{ds}$  is the electrostatic capacitance between the drain and source.

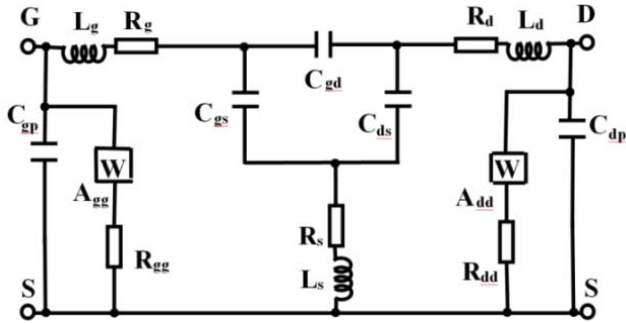

Fig. 8 Cold pinch-off equivalent circuit of GaN HEMT on Si-substrate

The measured S-parameters at this bias condition are converted to Y-parameters. Then the open structure Y-parameters are subtracted from the pinch-off Y-parameters to remove the substrate loading effect. The de-embedded pinch-off Y-parameters are then converted to Z-parameters to remove the effect of metallization inductances and access/contact resistances represented by the extracted values in Table II. After de-embedding the extrinsic elements, the de-embedded Z-parameters are converted to Y-parameters to characterize the intrinsic FET that can be represented by

$$Y_{11} = j\omega(C_{gs} + C_{gd}) \quad (5)$$

$$Y_{22} = j\omega(C_{ds} + C_{gd}) \quad (6)$$

$$Y_{12} = Y_{21} = -j\omega C_{gd} \quad (7)$$

Thus, the values of  $C_{gs}$ ,  $C_{gd}$  and  $C_{ds}$  can be extracted from slopes of the curves of intrinsic Y-parameters. This procedure has been applied to cold pinch-off 10 GHz S-parameters of the same considered 3.2-mm device at  $V_{GS} = -2.5V$  and  $V_{DS} = 0V$ .

Fig. 9 shows the model simulation for the measured pinch-off S-parameters of the device. As it can be seen, the model simulates the measurements in an excellent manner, which accordingly validates the proposed equivalent circuit model. The extracted values of  $C_{gs}$ ,  $C_{gd}$  and  $C_{ds}$  are 1.58 pF, 1.58 pF and 0.38 pF, respectively.

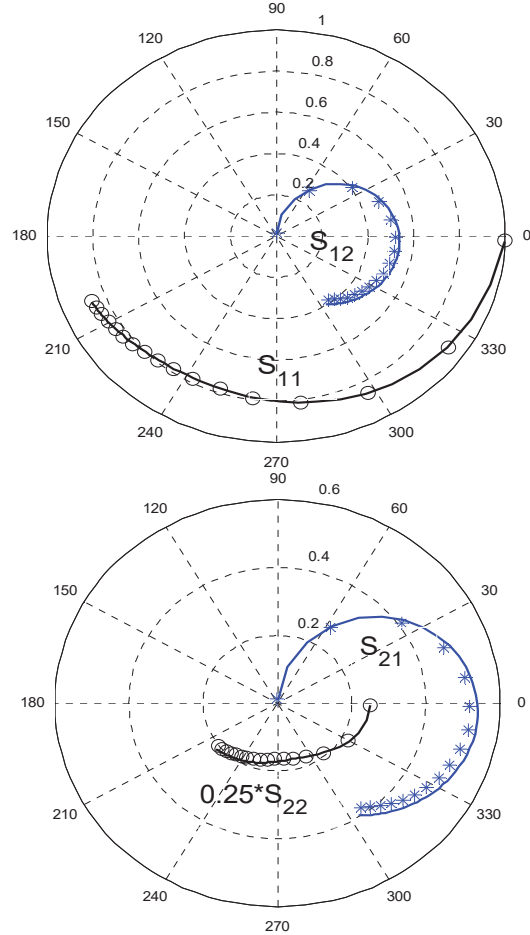

Fig. 9 Measured (symbols) and simulated (lines) pinch-off S-parameters of a 200x16 $\mu$ m GaN HEMT on Si Substrate at  $V_{GS} = -2.5V$  and  $V_{DS} = 0V$  for frequencies from 0.1GHz to 5 GHz

#### V. CONCLUSION

The results of this paper prove the applicability of using fraction-order elements such as the Warburg element to simulate transistor parasitic capacitances. The model showed an accurate simulation for S-parameters measurements. This approach could be improved to model the intrinsic of active devices, which is useful for efficient small- and large-signal modeling applications.

#### ACKNOWLEDGMENT

The authors gratefully acknowledge the support from the University of Sharjah, Sharjah, United Arab Emirates and LACIME Lab of École de Technologie Supérieure (ETS), Montréal, Canada, for providing the measurements.

## REFERENCES

- [1] U.K. Mishra, L. Shen, T.E. Kazior, and Y.-F. Wu, GaN-based RF power devices and amplifiers, *Proc IEEE* 96 (2008), 287–305.
- [2] E. Chumbes, A. Schremer, J. Smart, Y. Wang, N. MacDonald, D. Hogue, J. Komiak, S. Lichwalla, R. Leoni, and J. Shealy, AlGaIn/GaN high electron mobility transistors on Si(111) substrates, *IEEE Trans Electron Dev* 48 (2001), 420–426.
- [3] Liu, L., and J. H. Edgar, "Substrates for Gallium Nitride Epitaxy," *Materials Science and Engineering*, Vol. R 37, 2002, pp. 61–127.
- [4] Kaushik, J. K., V. R. Balakrishnan, B. S. Panwar, and R. Muralidharan, "On the Origin of Kink Effect in Current/Voltage Characteristics of AlGaIn/GaN High Electron Mobility Transistors," *IEEE Trans.*, Vol. ED-60, 2013, pp. 3351–3357.
- [5] J. C. Pedro and N. B. Carvalho, *Intermodulation Distortion in Microwave and Wireless Circuits*, Norwood, MA: Artech House, 2003.
- [6] S. Manohar, A. Narayanan, A. Keerti, A. Pham, J. Brown, R. Borges, and K. Linthicum, Characteristics of microwave power GaN HEMT's on 4-inch Si wafers, in *IEEE MTT-S Int Microwave Symp Dig 1* (2002), 449–452.
- [7] RiadhEssaadali, A. Jarndal, Ammar Kouki and F. M. Ghannouchi, "Modeling of Extrinsic Parasitic Elements of Si Based GaN HEMTs Using Two Step De-Embedding Structures," in the *IEEE Wireless and Microwave Technology Conference*, Cocoa Beach, Florida, USA, April 2015, pp. 1-4, (DOI: 10.1109/WAMICON.2015.7120399).
- [8] A. S. Elwakil, "Fractional order circuits and systems: An emerging interdisciplinary research area," *IEEE Circuits & Systems Magazine*, vol. 10, no. 4, pp. 41-50, 2010.
- [9] T. J. Freeborn, B. J. Maundy and A. S. Elwakil, "Extracting the parameters of the double-dispersion Cole bioimpedance model without direct impedance measurement," *Medical & Biological Engineering & Computing*, Springer, vol. 52, no. 9, pp. 749-758, 2014.
- [10] T. J. Freeborn, A. S. Elwakil and B. J. Maundy, "Fractional-order models of supercapacitors, batteries and fuel cells: A survey," *Materials for Renewable and Sustainable Energy*, Springer, vol. 4, no. 3, pp. 1-7, 2015.
- [11] A. Jarndal, A. Z. Markos, and G. Kompa, "Improved Modeling of GaN HEMT on Si Substrate for Design of RF Power Amplifiers," *IEEE Transactions on Microwave Theory and Techniques*, vol. 59, no. 3, pp. 644 – 651, March 2011.
- [12] A. Jarndal, "AlGaIn/GaN HEMTs on SiC and Si Substrates: A Review from the Small-Signal-Modeling's Perspective," *International Journal of RF and Microwave Computer Aided Engineering*, vol. 24, no. 3, pp. 389–400, May 2014.
- [13] A. Jarndal, Riadh Essaadali, and Ammar Kouki, "A Reliable Model Parameter Extraction Method Applied to AlGaIn/GaN HEMTs," *IEEE Transactions on Computer-Aided Design of Integrated Circuits and Systems*, vol. PP, no. 99, pp. 1-1, July 2015.