

Flow Measurement Using Magnetic Meters in Large Underground Cooling Water Pipelines

Humanyun Zahir, Irtam Ghazi

Abstract—This paper outlines the basic installation and operation of magnetic inductive flow velocity sensors on large underground cooling water pipelines. Research on the effects of cathodic protection as well as into other factors that might influence the overall performance of the meter is presented in this paper. The experiments were carried out on an immersion type magnetic meter specially used for flow measurement of cooling water pipeline. An attempt has been made in this paper to outline guidelines that can ensure accurate measurement related to immersion type magnetic meters on underground pipelines.

Keywords—Magnetic Induction, Flow meter, Faradays law, Immersion, Cathodic protection, Anode, Cathode, Flange, Grounding, Plant information management system, Electrodes.

I. INTRODUCTION

FATIMA Fertilizer installed a magnetic flow meter on a 36inch underground cooling water line with cathodic protection at the battery limit of Nitric Acid. A magnetic inductive flow velocity sensor had been installed at this pipeline for flow measurement. However the sensor had twice shown a very uncharacteristic behavior and thence it was believed that it was registering incorrect flow values. Thus a root cause analysis looking into factors which could have affected our transmitter was carried out. In this report a systematic approach has been adopted in which a step by step analysis of reasons that might cause erratic behavior of a flow meter is studied.

II. OPERATING PRINCIPLE OF MAG-FLOW [1]

It was in 1832 that Faraday conducted experiments on river Thames which were the first ones in the field of magnetic inductive flow measurement. His equation for electromagnetic induction is what the operating principle of magnetic flow meter is based upon. His law states that an electrical field E is produced in a conductive liquid moving through a magnetic field B at a velocity v in accordance with the vector product $E = [v \times B]$. Referring to Fig. 1 a liquid at flow velocity v and a flow rate Q flows through a meter tube (4), producing a measuring-circuit voltage U_M at the two electrodes (E1 and E2) at right angles to the direction of flow and the magnetic field B generated by the field coils (3). The size of this

measuring-circuit voltage is proportional to the mean flow velocity and thus flow rate.

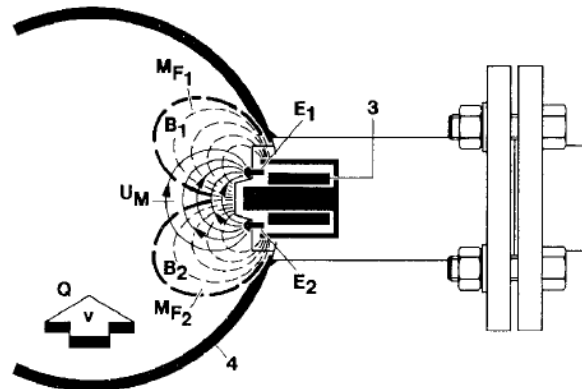

Fig. 1 Basic Operating principle of Immersion type Mag-meter

III. THE PROBLEM

The flow sensor has caused plant tripping due to a very unusual flow trend being depicted by the transmitter. This problem has occurred twice before however this time it also led to plant tripping. The transmitter has tripping on low flow and alarm on high value. The Process management system trend of the recent tripping caused by the flow sensor can be seen in Fig. 2.

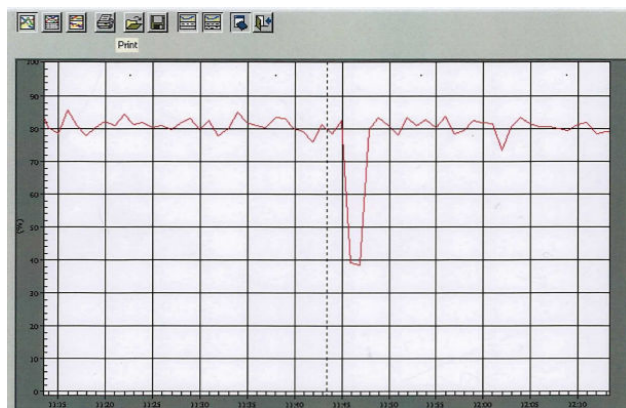

Fig. 2 Flow dip which caused plant tripping can be seen in PIMS trend above

IV. THE APPROACH

In the Root Cause Analysis that followed all factors that might affect the sensor were first jotted down and after that each factor was investigated and looked into. Below are all

Humanyun Zahir is with Fatima fertilizer Company Ltd, Sadiqabad, Pakistan. He is currently Unit Manager (Instrument) at Fatima Fertilizer Company Ltd. (phone: 092-685951000 ext. 2303; e-mail: Humanyun.zahir@fatima-group.com).

Irtam Ghazi is with Fatima fertilizer Company Ltd, Sadiqabad, TX 77005 Pakistan. He is now in the Department of E&I. (e-mail: irtam.ghazi@fatima-group.com).

major possible reasons that can affect a magnetic inductive flow sensor:

1. The flow actually declined and the transmitter was depicting the true flow rate.
2. Cathodic protection led to currents flowing through pipe body which caused a voltage drop
3. Improper grounding regulations had been observed which caused currents due to cathodic protection to flow through the electrodes resulting in erratic flow and flange corrosion
4. Due to the small distance between the electrodes and the nature of the service some solid particles or gas bubbles came in contact with the electrodes

V. FACTORS THAT AFFECT FLOW VALUES

A. Flow Decline

A transmitter showing irregular behavior is not always at fault but at times is serving its actual purpose and the pump or control valve etc. could be damaged and thus registering low flow values and therefore is an indication of some other problem. This is usually identified by monitoring flow rate changes downstream or upstream of the transmitter at the Process management system. On doing so it was identified that the transmitter was at fault.

B. Cathodic Protection

Corrosion is a degradation of material which results in loss of physical properties of the material. Cathodic protection is used on metal pipelines in contact with soil or moisture to prevent corrosion. On contact with soil a metal tends to get oxidized and form a layer of its oxide i.e. rust, which can easily peel off and thus in the longer term damage the pipeline. This damage can be so extensive that it can actually cause holes in pipelines. Therefore to prevent such a problem from occurring all underground metal pipelines that might come into contact with moisture are protected with cathodic protection. [2]

When two metals come in contact with an electrolyte both can oxidize by losing electrons however if the two metal electrolyte solution system was to be connected with a wire it would result in current flowing from metal higher up in the galvanic series to one lower in the series. This would protect the metal lower in the galvanic series. This is called sacrificial protection

An auxiliary DC power source can also be connected to drive current through this circuit as depicted below. This is called immersed current cathodic protection

The cathodic protection observed in our case was of immersed current type and causes currents to flow through the pipe. This could cause a magnetic field in the pipeline and affect our transmitter's values. If large currents were to flow this could have caused the tripping. Immersed Current cathodic protection is depicted in Fig. 3. However on reading the current values it was found that current values in the entire pipe section were quite large which is shown in Table I.

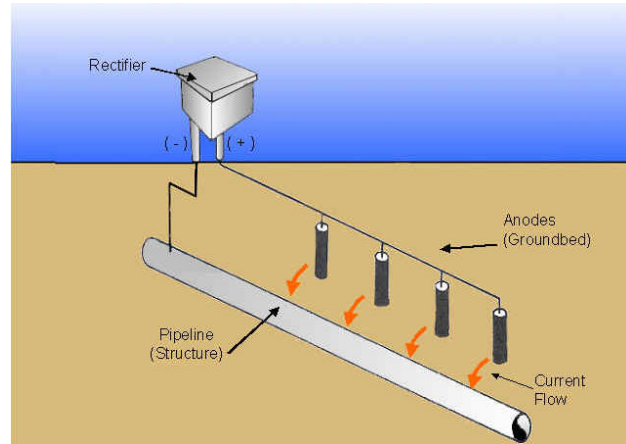

Fig. 3 Immersed Current Cathodic Protection [3]

As a result, an analysis of flow registered at different current values was carried out. At different current values flow registered by Process management system were monitored. It was ensured that the water pipeline was operated under the same conditions at different current values. A graph showing the predicted relationship Fig. 4 and the relationship depicted by our transmitter Fig. 5 can be seen in the next page. As can be seen in Fig. 4 flow values are adversely affected by immersed current cathodic protection. However this can be prevented by following the proper grounding guidelines. For this an explanation of proper grounding guidelines is required.

TABLE I
PSP VOLTAGES AND ICCP CURRENT VALUES
NITRIC ACID PLANT

T/R Values	Oct, 2012	May, 2014
T/R#18	15V, 22A	12V, 8A
T/R#19	23V, 17A	30V, 5A
Min		
Max	0.865V	0.780V

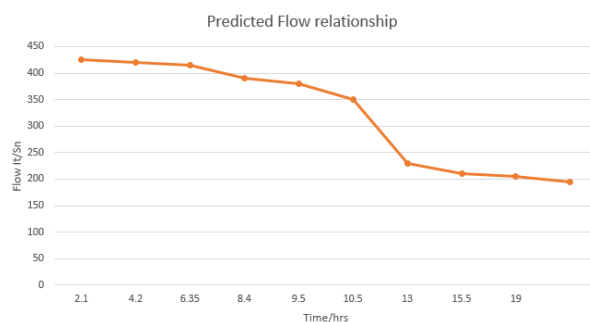

Fig. 4 Predicted Flow Results [4]

C. Grounding Regulations

Proper grounding of transmitter and sensor is very necessary for accurate flow measurement. This is especially true in pipelines with cathodic protection. Two important factors will be discussed here;

1. The sensor installed in a pipeline with cathodic protection should not be connected to plant earth rather it should

only be connected only with the transmitter. Connection with earth makes our sensor flange act as the anode and thus causes its corrosion. Therefore it is pertinent to ensure that the flange is grounded.

2. The transmitter and sensor should be connected together. This ensures that due to false currents through the sensor, it will not experience a higher potential value which is due to cathodic protection currents. Thence this helps maintain a common reference for both transmitter and sensor.

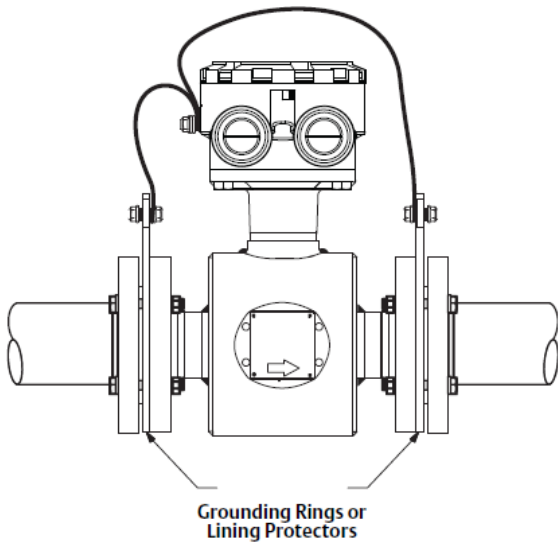

Fig. 5 Grounding regulation observed on our transmitter [5]

Now the trend seen in Fig. 5 is that with proper grounding regulations for an underground pipeline with cathodic protection. As can be seen, this method of grounding ensures that cathodic protection has minimal effects on flow measurement. Thus due to the trend depicted, our transmitter could not have caused the flow dip shown by our Process Management system

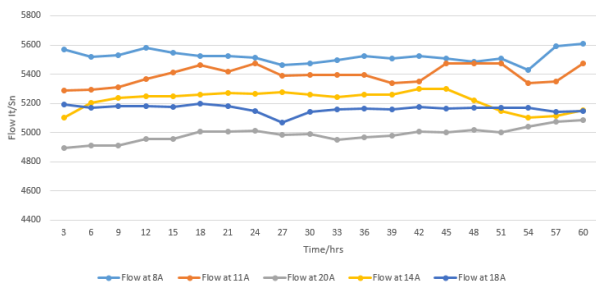

Fig. 6 Experimental results

As can be seen in the graph the variation with ICCP current values is very small over a very large range of current values. Remember while these current values do not depict current in any one section they are a good estimate of over all current variation in that section.

The graph below depicts average flow value at different

cathodic protection current values. This better depicts flow relationship with current

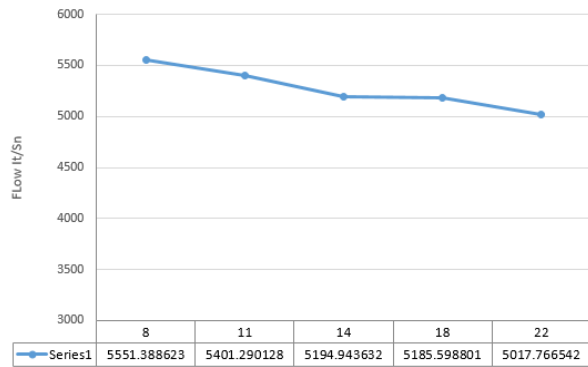

Fig. 7 Average Flow VS Current Graph

D. Air Bubbles or Small Solid Particle Passing

As shown in Fig. 7 the transmitter is top mounted and thus naturally the possibility of air bubbles flowing on the top portion of the pipe might pose a problem. As the sensor has both electrodes and magnetic field generating coils in very close proximity, large air bubbles passing in front of the sensor will change the magnetic inductance of the liquid and hence change the flow value.

Furthermore this phenomenon is made worse because of the much smaller area over which the magnetic field is able to pass through compared to the much larger pipe and to further complicate matters the EMF value is very small and thence easily affected. However even though this is a very probable reason but pipe pressure helps determine the possibility of air bubbles. The pipeline under consideration was pressurized at 8 bar and thence the possibility was very low [4]. Furthermore the flow sensor was immersed 5 inches into the pipeline.



Fig. 8 Mounting position of sensor

However on examining the water sample it was found that along with the water, solid particles and sometimes even plastic wrappers flowed through the pipe line. This helped identify the problem, instead of air bubbles it were solid particles flowing through the water that when flowed in front of the pipeline changed the liquids magnetic inductance. This phenomenon is not observed in normal magnetic meter which have electrodes at each diametric end of the pipeline and

magnetic coils wrap the entire flow tube section. Thus the passing of these solid particles resulted in change in the inductance of our fluid and caused our very small EMF signal to be affected. Two solutions were proposed for this problem:

- 1) The installation of a filter to clean the fluid however the filter would require cleaning and could get clogged. Such high maintenance was not possible at a cooling water pipeline and thus the proposition was dismissed.
- 2) The installation of another sensor and both acting in 2 out of 2 logic was considered. Steps were also taken on this proposition and as Fig. 7 depicts arrangements for the installation of the sensor are already available. This proposition is being acted upon

VI. CONCLUSION

In industry economics often dictates our choice of transmitters. Now, while our ultimate goal is accurate flow measurement at an economic cost, we must know how to use different transmitters in varying process and environment conditions. The paper outlines a problem that can occur due to the close vicinity of sensor and magnetic coils and the smaller measurement area along with possible surrounding i.e. cathodic protection affects. The solution formed to this problem was to mount another sensor in the new flange position visible in Fig. 7. This is because in large pipelines immersion type flow meters are the only viable choice and thence some other type of mag meter cannot be used.

ACKNOWLEDGMENT

We are thankful to Fatima Fertilizer Company Ltd. for providing us the means of carrying out this research. Also we acknowledge the contribution made by the technicians of Fatima fertilizer who also helped us conduct our research.

REFERENCES

- [1] Heinrichs Messitechnik, "PIT Magnetic-Inductive Flow Velocity Sensor," Heinrichs Messitechnik, Germany.
- [2] C. T. Laboratory, "Fundamentals of Corrosion and Corrosion Control," (Online). Available: http://corrosion.ksc.nasa.gov/corr_fundamentals.htm. (Accessed 26 November 2014).
- [3] Corrosion Engineering, "Impressed Current Systems," (Online). Available: <http://faculty.kfupm.edu.sa/ME/hussaini/Corrosion%20Engineering/05.03.04.htm>. (Accessed 20 December 2014).
- [4] S. Gundogda and O. Sahin, "E.M.I effects on Magnetic Inductive Flowmeters," *Sensors*, vol. 7, pp. 75-83, 2007.
- [5] Emerson Process Management, "Installation and Grounding of Magnetic Meters in Typical and Special Applications," Emerson, 2007.