

Feasibility of Integrating Heating Valve Drivers with KNX-standard for Performing Dynamic Hydraulic Balance in Domestic Buildings

Tobias Teich, Danny Szendrei, Markus Schrader, Franziska Jahn and Susan Franke

Abstract—The increasing demand for sufficient and clean energy forces industrial and service companies to align their strategies towards efficient consumption. This trend refers also to the residential building sector. There, large amounts of energy consumption are caused by house and facility heating. Many of the operated hot water heating systems lack hydraulic balanced working conditions for heat distribution and –transmission and lead to inefficient heating. Through hydraulic balancing of heating systems, significant energy savings for primary and secondary energy can be achieved. This paper addresses the use of KNX-technology (Smart Buildings) in residential buildings to ensure a dynamic adaption of hydraulic system's performance, in order to increase the heating system's efficiency. In this paper, the procedure of heating system segmentation into hydraulically independent units (meshes) is presented. Within these meshes, the heating valve are addressed and controlled by a central facility server. Feasibility criteria towards such drivers will be named. The dynamic hydraulic balance is achieved by positioning these valves according to heating loads, that are generated from the temperature settings in the corresponding rooms. The energetic advantages of single room heating control procedures, based on the application *FacilityManager*, is presented.

Keywords—building automation, dynamic hydraulic balance, energy savings, VPN-networks.

I. INTRODUCTION

ONE of today's most challenging and global problem is providing clean energy for increasing industrial and residential demands. Industry and service companies are forced to align their energy consumption towards more efficient strategies. Facility management, especially in the

residential housing sector, can contribute large potentials to increase energy efficiency. In Europe, about 50% of the overall energy-consumption is caused by buildings/facilities. A share of about 70% of that consumption is used for heating systems. Because of architectural reasons, that consumption is aggregated locally. Thus, local energy networks can be used to control that consumption. Furthermore, the high share of out of date building services highlights those potentials. Invests in high efficient heat generators are deferred especially in the residential housing sector. Next to heat generation, the probabilities of energy savings in heat distribution systems are not used adequately. In the future, the importance of hydraulic balanced systems is expected to increase, due to tightened legal restrictions [2]. Conventional hot water heating distribution systems, such as double-pipe-networks, are technically mature and of high durability. There are still opportunities for energy saving in about 90% of all operated heating systems. This is caused by the missing hydraulic balance within those systems. The after-effects are delayed heat-up over the building, variable hydraulic conditions, increasing energy consumption (primary and secondary energy) and disturbing floating noises. In simulations, FELSMANN and HIRSCHBERG found out, that hydraulic imbalanced buildings cause 8% higher mass-flow-turnover than optimized buildings [3], [4]. This additional turnover results in a 25% rise of electrical energy demand for the heating turnover pumps. Estimations of the overall energy consumption of heating systems rate imbalanced buildings with the factor 1.08 higher than balanced ones [6]. One major influence on that consumption can be found in the interference between primary and secondary energy allocation.

KNX-technology enables controlling local networks in a variety of functions, such as power distribution, heating control, security installations and others. The VPN-based bus integrates sensors and actors of a network (for instance residential buildings) and thus enables holistic control procedures. Current room temperature control systems anticipate many environmental parameters and self-adjust heat generator settings as well as heating valve settings within the rooms. Caused by numerous temperature settings through the users, the hydraulic conditions within a single pipe vary and influence the proper hydraulic supply of remaining heating devices within the same line [10]. Due to heterogeneous settings of different users, conventional measures of hydraulic balance fail to compensate dynamic changes of difference pressure, caused by the named reason [1]. Via valve drivers on each heating device and the intelligent integration of the

T.Teich is with the University Of Applied Sciences Zwickau, Zwickau, Germany (corresponding author to provide phone: +49 375 536 3415; fax: +49 375 536 3104; e-mail: tobias.teich@fh-zwickau.de).

D.Szendrei is with the University Of Applied Sciences Zwickau, Zwickau, Germany (corresponding author to provide phone: +49 375 536 3431; fax: +49 375 536 3104; e-mail: danny.szendrei@fh-zwickau.de).

M.Schrader is with the University Of Applied Sciences Zwickau, Zwickau, Germany (corresponding author to provide phone: +49 375 536 3250; fax: +49 375 536 3104; e-mail: markus.schrader@fh-zwickau.de).

F.Jahn is with the University Of Applied Sciences Zwickau, Zwickau, Germany (corresponding author to provide phone: +49 375 536 3250; fax: +49 375 536 3104; e-mail: franziska.jahn@fh-zwickau.de).

S.Franke is with the University Of Applied Sciences Zwickau, Zwickau, Germany (corresponding author to provide phone: +49 375 536 3250; fax: +49 375 536 3104; e-mail: susan.franke@fh-zwickau.de).

drivers in bus structures, the valve settings can be used to compensate these dynamics. As far as the hydraulic specifications (i.e. difference pressures throughout all working conditions, characteristic diagrams of heating valves, valve driver ranges) of the pipes are known, the valve positioning can be controlled by a central facility server application. Thus, different load scenarios of the heating system can be considered in the controlling algorithms for each room in a specific pipe and ensures dynamic hydraulic balance.

II. DESCRIPTION OF BUILDING SERVICES

A. Conventional Building Services

Smart home infrastructures or holistic control systems have not been installed in most multi-storey dwellings. The

TABLE I
NOMENCLATURE

Symbol	Meaning	Unit
c_p	specific heat	[kJ/Kg·K]
f_{pj}	rating factor or primary energy	n.d.
l	length	[m]
\square	mass flow rate	[Kg/s]
P	pressure	[Pa]
Q_p	primary energy demand	[W]
R_0	thermal resistivity	[(m ² ·K)/W]
r_v	valve range	[%]
ζ	pressure loss	n.d.
w	flow velocity of water	[m/s]
ρ	density (water)	[Kg/m ³]
V	volume flow	[m ³ /s]
ϱ	temperature	[K]

development of home or building automation is only about to start in private residential or commercial buildings [8]. So far, most installations and their control systems have been conducted by companies of different crafts or branches. In this facility management scenario, integrative control procedures are hard to achieve. In the field of heating, integrative building control was impossible to maintain, due to the following systems characteristics:

Most of the used heating technology consists of the modules heat generation, heat distribution and heat transmission [11]. Especially heat transmission and its control are still structured according to the dwelling units of the buildings. Due to heterogeneous heat allocation, most heating systems work inefficiently [6]. This effect appears most notably in large heating systems [3]. About 70% of residential buildings are equipped with central heating systems with two-pipe installations (for- and backward motion) [6]. Based on main heat distributing pipes, that are installed horizontally, numerous rising pipes supply the rooms of the buildings vertically. Each rising pipe distributes the corresponding

heating devices with mass flow of hot water and represents a single mesh. These meshes mostly correspond with the vertical dwelling unit structure. Within a mesh, the hydraulic conditions vary according to:

- mesh-distance to circulation pump,
- storey height,
- parameters of installed system components,
- user settings.

Within single dwellings, the user is capable to optimize his habits (heat demand) towards cost-minimisation and comfort-maximisation. These local optima interfere and do not necessarily lead to an efficient heat supply over the meshes and the whole building. The determinants of the efficiency are primary and secondary energy. It is important to understand the interference between the required energy of the used energy carrier (primary), and the necessary electrical energy for controlling and distributing (secondary) the generated mass flows, according to the equation:

$$Q_p = \sum_j Q_j \cdot f_{pj} \quad (1)$$

Beside physical influences of the building (hull damping, internal heat transmission etc.), user settings determine the primary energy demand significantly [1], [4]. Due to the presented standards in building services, there is a lack of information about user settings and their effects (thermal and hydraulic) within the distribution system. Individual control sequences and thus mass flow distribution are not aggregated for optimal operation. Hydraulic balancing of the heating systems is often used to achieve more efficient heat distribution. There are still about 90% of all operated systems, where such measures have not been conducted [6]. Standard procedures of hydraulic balancing cover hydro-static adjustments for heating loads under extreme circumstances (full load). In this condition, the proper mass flow distribution can be obtained throughout the system by adjusting proper resistance at the heating valves. In that case, every opened valve enables a homogeneous heat supply of all heating devices. More realistic load profiles have to cover partial heating scenarios. In these cases, that occur throughout 95% of the heating season, significantly smaller mass flows have to be circulated by the distribution system. The mass flow is object to dynamic user settings [10]. That way, the statically adjusted resistances are out of tolerance and do not ensure homogeneous mass flows. The effects of imbalanced working conditions are:

- effects on comfort:
 - delayed heat-up of single dwellings/rooms,
 - flow noises,
 - declined control quality of thermostatic valves.

- effects on efficiency:
 - increased demand in primary/secondary energy,
 - rising operation expenses,
 - increasing backward-motion temperatures,
 - decreasing system durability.

This forces the control system to react dynamically to the load profiles at the heating valves. To anticipate the hydraulic

interferences between the dwellings, it is essential to control the mass flow of each mesh that supply different heating devices over the storeys. Therefore, the configuration of the KNX-network must consider the systems installation of rising pipes and its attached devices. For each rising pipe, calculations of:

$$\dot{m}_{mesh} = \frac{\sum \dot{Q}}{c_p \cdot \Delta \vartheta} \quad (2)$$

and

$$\Delta p_{mesh} = \sum (R \cdot l) + \sum \left(\zeta \cdot \frac{\rho \cdot \omega^2}{2} \right) \quad (3)$$

have to be performed. With these information, different load scenarios can be modelled and deposited for facility server applications. According to heating demand in the meshes, valve ranges can be tuned in to dynamically balance the meshes mass flow and ensuring adequate heat supply. The advantage of this approach is the coverage of static and dynamic load profiles. In general, heating valves in lower storeys require a higher hydrostatic resistance (bigger valve range). In accordance with the number of storeys, the necessary resistance is to be decreased. The implementation of this control requires accurately working valve drivers. These are to be found among KNX-based, continuously controlled drivers.

B. Integration Of BS Into KNX-Networks

The features of KNX-based technical equipment enable the setup of holistic (energy-) consumer networks. The main advantage of that technology is that various applications around building services can be controlled on a single, integrative platform. The portfolio of available and reliable components contains various components of different applications. Different applications, though, can be managed and configured on the ETS-software (European Installation Bus Tool Software) for facility server operations.

As demonstration and try-out objects, two multi-storey residential buildings have been equipped with KNX-based actors and sensors. Applications of heating control, electric appliance control, protection/security control and others are installed. Besides control procedures, the KNX-network enables visualisation, remote operations, flexible billing and individual setups of the installed components [8].

In the field of heating control, the existing building service hardware (i.e. heating devices, pipes, heat generator) did not have to be renewed. The functionality of heat generation and distribution hardware was available for restarting it with KNX-based valve drivers. Thus, integrative control procedures of room temperature and heat generator settings are enabled throughout the building. The valve drivers are addressable, continuously controllable units with a total range of 3 millimetres, that replaced the existing thermostatic valves [9]. With such drivers, conventional valve-cores became easy to control.

Inside the buildings, the equipment is linked via Ethernet. The communication between both buildings (and other external facilities) is transacted over VPN's. Those provide a private communications network over a shared public network infrastructure such as the Internet. Basically, there are three types of virtual private networks: Remote access VPN connection (end-to-site), Branch Office VPN connection (site-to-site) and Extranet VPN connection (end-to-end) [8]. The demonstration objects are interconnected by a site-to-site VPN connection. Regarding security issues, VPN's provide high protection against external access.

Each KNX component within the network is to be addressed by physical or group-addresses. In general, the systems setup covers the dwelling structure within the facilities according to Fig. 1:

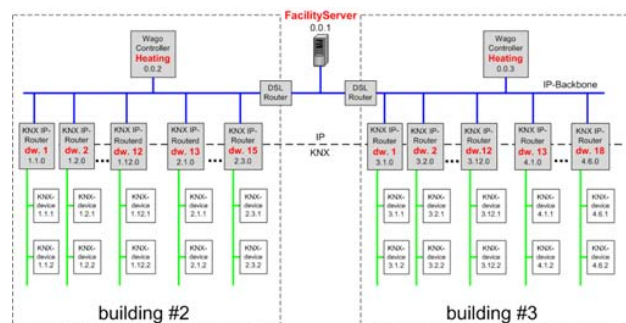

Fig. 1. KNX-topology of the heating control in demonstration dwellings

As shown above, the KNX-topology is designed in order to assign each component to a specific dwelling. Functions or settings execution, that are required by the user, as well as the periodic billing of energy consumption is assured that way. To implement the heating control, including dynamic hydraulic balance, the mesh topology of the heat distribution system has to be considered. Thus, the affiliations of temperature sensors and valve drivers to the corresponding rising pipes were modelled and configured in the facility server.

C. Data-Integration From Different Systems

As mentioned in *par. 2.B*, the ETS platform enables the setup and configuration of the KNX devices (configuration data). Regarding the various functions of the different components, the ETS platform is inadequate to manage all operational data (life data). For that reason, an independent data management system *FacilityManager* was implemented. The structure of the integrated database accounts for the building/dwelling structure as well as the KNX-topology. With that information structure, a straight assignment of components functions, time stamps, consumptions, settings and other information to single users is possible.

III. IMPLEMENTATION OF SINGLE ROOM TEMPERATURE CONTROL

A. Operational Description

Conceptual core of the heating control is maintaining single room temperature control. This ensures the appropriate

comfort, required by the user. The aim of the control is to harmonize the resulting differences in mass flow, that are caused by diverse, interfering user temperature settings.

KNX components for single room control are a temperature sensor, a heating actor and a heating device valve driver. This setup refers to a single room with one heating device [7]. The desired set temperature is specified as a temperature profile in the facility server by the user. Individual temperature profiles can there be set minute-by-minute. The value of the actual temperature is compared to the set temperature value by the installed sensor via telegram-communication. Contrary to thermostatic valve controls, the sensor is positioned on the heating device facing wall. That is to provide pure values of the actual temperature. As an offset for the single room temperature control $|\mathcal{G}_{\text{set}} - \mathcal{G}_{\text{act}}| \geq 0.5\text{K}$ has been adjusted. This offset prevents the control system from oscillating [5]. On the other hand, it is approved to assure a satisfactory thermal comfort for the user [6]. The facility server based controller tracks the actual temperature values of each room by requesting KNXnet/IP-telegrams from the devices. This communication is transacted full-time in a two minute frequency. The exchanged information is then used to measure the offset. In case of an actual temperature, being more than 0.5K lower than the set value, a heating demand for the corresponding room is generated. In such a case, a decision variable HD is set true. According to the combinations of heating demands within a mesh, specific load profiles and assigned valve ranges are deposited. Table II presents all possible heating load profiles and the assigned valve ranges for a dynamic hydraulic balance in a three storey mesh [7].

TABLE II
POSSIBLE HEATING LOAD PROFILES

decision variable value (HD) for heating demand			valve range R [%]		
ground floor	1 st floor	2 nd floor	R_{GF}	$R_{1^{st}}$	$R_{2^{nd}}$
0	0	0	0	0	0
0	0	1	0	0	100
0	1	0	0	100	0
0	1	1	0	75	100
1	0	0	100	0	0
1	0	1	75	0	100
1	1	0	75	100	0
1	1	1	65	75	100

In each control sequence, the corresponding load profile is recalled in accordance to the offset measurement. The ranges for the meshes valves are then assigned to the heating actors and valve drivers via KNXnet/IP-telegrams. The valve driver (re-) positions itself (corrective action) and sustains that position until the next telegram request. During a control sequence, only one load profile is valid [7].

The valve ranges are calculated on the basis of their specific character diagrams. From the difference pressure calculation (see par. 2), the values of choking hydraulic resistance are known. Over each mesh, these values can be expressed as

ratios towards the total difference pressure. Within a mesh, each integrated valve produces an individual difference pressure. Thus, the corresponding ratios can be used to determine the valve ranges, that create the required choking resistance, resulting from:

$$k_v = \dot{V} \cdot \sqrt{\frac{1\text{bar} \cdot \rho}{\Delta p \cdot 1000 \text{ kg/m}^3}} [\text{m}^3/\text{h}] \quad (4)$$

and

$$\dot{m} = \rho \cdot \dot{V} [\text{kg/h}] \quad (5)$$

According to the control frequency of two minutes, the valve positioning assures a dynamic balancing of mass flow. That way, the hydraulic efforts of the heating system can be reduced by about 8% [6]. Consequently, the secondary energy consumption can be derated 25%, with regard to the simulations of GUZEK. To efficiently implement the control system with KNX-based valve drivers, their metering characteristics are to consider.

B. Metering Characteristics- Feasibility Criteria Of Valve Drivers

Basically, different types of valve drivers are available. To ensure effective, dynamic adaption of the heating device valve positions, the parameters operating speed and control frequency are to harmonize. As a matter of fact in residential facility management, procurement, installation and servicing costs have to be kept low. These named attributes are feasibility criteria for the driver selection. Reliable devices with the following metering characteristics are available as thermal drivers and electromotive drivers.

(i) thermal drivers:

These discontinuously acting drivers usually work as two-position controllers. Heating device valves can be positioned to the *opened* and *closed* position [12]. The control signal for the drivers is generated by the facility server. After its transaction to the KNX-based heating actor, a voltage is triggered to the driver. This voltage is used to heat-up a thermal resistor, that devolves its extension onto the valve. This technology is comparatively cheap. Major disadvantage is the inaccurate controlling of the valve motion. This is caused by the required heat-up time (t_1-t_2), which is varying under certain circumstances. Furthermore, the average heat-up time from two minutes exceeds the available cycle time of the control procedure. Regarding these characteristics, accurate valve positioning with two-position controllers seems impossible. Another possibility is controlling thermal valve drivers through pulse width modulation (PWM). That modulation can be achieved by time-dependent applying of voltage to the valve driver. The pulsing periods have to consider heat-up as well as valve motion duration, in order to maintain a virtual continuous control. Fig. 2 presents the time-dependent activity of the presented controllers. For simplification, the down time of the virtual continuously acting controller (break of voltage supply), is not illustrated.

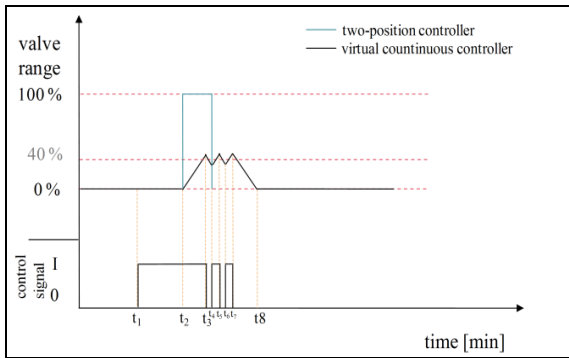

Fig. 2. Time-dependent metering characteristics

The modulation probabilities of the virtual continuous controller require instant and fast valve motions. Due to the components characteristics, motions are delayed and unsteady. The aim of dynamic and high frequency mass flow adaption is not to be implemented with the named drivers.

(ii) electromotive drivers:

As an alternative, electromotive valve drivers can be used. There are many suppliers who offer these drivers with KNX-interfaces. The metering characteristic of such components is continuous control. In general, two control types are common. First: voltage-proportional controllers. These drivers are supplied with a voltage from 0.5 to 10 V. According to the applied level, the valve driver conducts a forward motion that is devolved onto the valve [9]. In addition to the bus cable, a power line has to be installed for implementing this technology.

Second control type is a binary coded positioning system within the drivers. A range recognition system precisely positions the valve, according to the incoming control signal. The signal is transmitted via KNXnet/IP-telegrams. The telegrams contain a two bit message, that represent the required valve setting. Beside the accurate positioning capabilities, the small effort for installation is to be highlighted. Only bus cables are to be installed throughout the building. One disadvantage of this technology are higher procurement costs.

To achieve an optimal technical infrastructure, the trade-off between metering characteristics and procurement, installation and servicing costs of the valve drivers had to be evaluated. Regarding the high controlling potentials of electromotive drivers and their higher durability, this technology was chosen for implementation.

IV. RESULTS

As mentioned in par. 2, two residential buildings have been equipped with an entire KNX infrastructure. The various actors and sensors especially cover heating and electrical energy consuming appliances. For the installation periphery, more than thirty single components have been installed in every 2- or 3-bedroom dwelling. Another dozen components assure the system's operation and control as centralized control devices in the basements of the facilities.

The topology of a reference dwelling is illustrated in Fig.3:

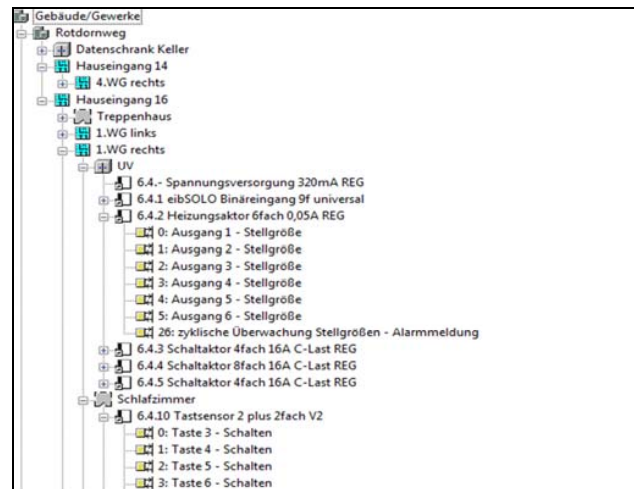

Fig. 3. KNX-topology of reference dwelling

With the value requests by the application *FacilityManager*, the single room temperature control could be accomplished. First evaluations of the convergency of actual and set temperature values indicate a uniform heat-up of the dwellings within the meshes. More detailed analyses are to be carried out in the upcoming heating season. Furthermore, the electrical power consumption of the circulation pump was measured. In comparison to similar workloads, measured before the systems renewal, first savings could be detected. For further proof, the circulation system will be compared to a hydraulically non-balanced system with similar parameters.

V. CONCLUSIONS

Increasing the heating system's efficiency can contribute large potentials to general energy savings. These potentials are to point up, when regarding the huge share of domestic buildings without optimized central heating systems. In about 90% of these buildings in Germany, heat distribution and transmission components lack hydraulic balanced operating conditions. By launching smart building infrastructures, such as the KNX-standard, new control scenarios for various building services can be implemented. The application of VPN-connected control components enables hydraulic balancing while maintaining single room temperature control throughout (large) domestic buildings. To assure homogenous mass flow allocation, the heat distribution system was segmented into hydraulically independent meshes. Within each mesh, KNX-based heating valve drivers are positioned in accordance to the corresponding heating load profile. The determination of load profiles is achieved by requesting actual temperature values via KNXnet/IP telegrams. The values from all rooms are assigned to the specific mesh structure. In different trials, electromotive valve drivers were found to act most feasible while affording high durability. Such drivers are characterised by fast and precise range adaption. The installation effort for the presented infrastructure remains comparatively low. First energy savings, caused by hydraulic

balanced heat-up of the building, were measured at the circulation pump. Because of the balanced hydraulic workload, the electric energy consumption could be reduced. Due to mild weather conditions, these savings in electric power consumption for the distribution system, are to evaluate as initial estimations. High decomposition measurements of the temperature spreading (for-backward motion) will indicate the homogenous heat distribution over the meshes. These measurements are initialized for the upcoming heating season. Detailed calculations and utility analyses are tasks for the further project work.

Regarding the feasibility of other building services, that have to be integrated into the KNX-network technology, more flexible and comfortable control procedures can be established. For instance, the interference of light irradiation, heating and ventilation can be integrated into automated control scenarios for large facilities.

REFERENCES

- [1] X. Baopin, F. Lin and D. Hongfa, "Field investigation on consumer behavior and hydraulic performance of a district heating system in Tianjin, China." *Building and Environment*, vol 44, 2009, pp. 249-259.
- [2] German Department of Justice, *Verordnung über energiesparenden Wärmeschutz und energiesparende Anlagentechnik bei Gebäuden (Energieeinsparverordnung – EnEV.)*, 2009.
- [3] C. Felsmann and R. Hirschberg, *Das Rohrnetz in Heizungsanlagen: eine Analyse des Teillastverhaltens und der Effizienz von Rohrnetzen*. VDI-Verlag Düsseldorf, 2007.
- [4] N. Fumo, J.M. Pedro and L.M. Chamra, "Energy and economic evaluation of cooling, heating and power systems based on primary energy" *Applied Thermal Engineering*, vol. 29, 2009, pp. 2665-2671.
- [5] GIRA (edt.), "*Instabus EIB System, Tastsensor 2plus 2-/5fach mit Beschriftungsfeld*", Giersiepen, technical documentation, 2006.
- [6] G. Guzek, *Zur Energieeinsparung in Heizungsanlagen durch den hydraulischen Abgleich.*, Dresden, TUDpress, 2010.
- [7] D.Szendrei, „Machbarkeitsstudie des hydraulischen Abgleichs von Heizungsanlagen mittels thermischer Stellantriebe in Smart Homes unter Annahme gebäudespezifischer Nutzerprofile“, University Of Applied Sciences Zwickau, 2010, to be published.
- [8] T. Teich, M. Zimmermann, S. Franke, F. Jahn and M. Schrader, „Intelligent Building Automation“, *ISRST International Conference on Automation, Robotics and Control Systems*. Orlando, Florida, 2010, pp. 53–57.
- [9] Theodor Heimeier Metallwerk GmbH, „*EMO EIB Elektromotorischer Stellantrieb für den Direktanschluss an den Europäischen Installationsbus*“, Erwitte, technical documentation, 2010.
- [10] R. Yao and K. Steemers, "A method of formulating energy load profile for domestic buildings in the UK" *Energy and Buildings*, vol. 37, 2005, pp. 663-671.
- [11] J. Seifert, Ein Beitrag zur Einschätzung der energetischen und exergetischen Einsparpotentiale von Regelverfahren in der Heizungstechnik, TUDpress, Dresden, 2009.
- [12] Y. Zou, *Unstetige Wärmeversorgung im Mehrfamilienhaus*, Universitätsverlag Karlsruhe, 2008.