

# Fairness and Quality of Service Issues and Analysis of IEEE 802.11e Wireless LAN

Ammar Abbas, Ibrahim M. Hussain and Osama M. Hussain

**Abstract**—The IEEE 802.11e which is an enhanced version of the 802.11 WLAN standards incorporates the Quality of Service (QoS) which makes it a better choice for multimedia and real time applications. In this paper we study various aspects concerned with 802.11e standard. Further, the analysis results for this standard are compared with the legacy 802.11 standard. Simulation results show that IEEE 802.11e out performs legacy IEEE 802.11 in terms of quality of service due to its flow differentiated channel allocation and better queue management architecture. We also propose a method to improve the unfair allocation of bandwidth for downlink and uplink channels by varying the medium access priority level.

**Keywords**—Wireless; IEEE 802.11e; EDCA; Throughput; QoS; MAC.

## I. INTRODUCTION

IEEE 802.11 wireless LAN (WLAN) is becoming one of the most deployed wireless technologies all over the world and is likely to play a major role in next-generation wireless communication networks [1]. The possibility of WLAN's coexistence with 3<sup>rd</sup> and 4<sup>th</sup> generation cellular networks [2] makes it more vital for up gradation and improvement. The main characteristics of the 802.11 WLAN technologies are simplicity, flexibility and cost effectiveness. This technology provides people with a ubiquitous communication and computing environment in various places. Further, since multimedia applications have experienced an explosive growth, end users require high speed video, voice and Web services. However, multimedia applications require QoS in terms of guaranteed throughput, minimum delay and low packet loss. Guaranteeing these QoS requirements in 802.11 WLAN is very challenging and substantial amount of work has been done to ensure QoS and higher data rates in WLAN environment [3-5]. IEEE 802.11e [6] and IEEE 802.11n [7] standards are introduced for enabling QoS and for improving data rate requirements respectively. In this paper we focus upon the simulation based results to make an analysis on the QoS issue for both these standards.

The paper is organized as follows: the second section gives an overview of IEEE 802.11 legacy WLAN standard while

details about IEEE 802.11e standard are presented in section 3. The simulation tools and the simulation environment being used are discussed in section 4. The analysis of these results is provided in section 5. Further, fairness analysis of uplink and downlink throughput in IEEE 802.11e is given in section 6 along with a proposed method to improve such fairness throughput. Finally we make conclusions on these results in section 7.

## II. AN OVERVIEW OF IEEE 802.11 LEGACY STANDARD

An IEEE 802.11 LAN (Local Area Network) is based on a cellular architecture where each cell is called Basic Service Set (BSS). These cells are controlled by a base station called Access Points (APs). The interconnection of these wireless LANs is called Extended Service Set (ESS). Three different physical layers are provided for possible implementation [8]. One is based on Infrared (IR) communications, and the other two are frequency-Hopping Spread Spectrum (FHSS) and Direct Sequence Spread Spectrum (DSSS) techniques.

Legacy IEEE 802.11 MAC has two types of medium access methods [9]. The first one is used during contention free period called Point Coordination Function (PCF) and the other is used during contention period called Distributed Coordination Function (DCF). In this paper we confine our study to the DCF as this implementation is more widely used than PCF.

DCF is a distributed medium access scheme in which every station must sense the medium before initiating a packet transmission. If the medium is found idle for a time interval longer than Distributed Inter-Frame Space (DIFS), then the station can transmit the packet, otherwise the transmission is restrained and the back off process starts. Back-off procedure is devised as such to minimize the chances of two stations ending up with the same time of sending packets. Each station computes a random time interval called Back-off time which is uniformly distributed between zero and the current Contention Window size (CW). This time slot depends on the type of physical layer being used. The back off timer is decreased only when the medium is idle but when a station starts transmitting, the timer is halted. A positive acknowledgement is used to notify the sender that the transmitted frame has been successfully received. Acknowledgement is sent after the Short Inter Frame Space (SIFS) with the reception of frame. SIFS is smaller than the DIFS and hence the receiving station does not need to sense and apply back-off procedure to transmit an

Ammar Abbas<sup>1</sup> and Ibrahim M. Hussain<sup>2</sup> are with the Department of Computer Engineering, Sir Syed University of Engineering and Technology, Karachi 75300-Pakistan. phone: 092-21-4988000-284; fax: 092-21-4982393; e-mail: ammarabbas@gmail.com<sup>1</sup>, hmmiharbi@yahoo.com<sup>2</sup>.

Osama M. Hussain is with the Communication & Information Research Center (CIRC) - Sultan Qaboos University, Muscat-Oman. e-mail: osama.mhussain@gmail.com

acknowledgement. If the acknowledgement is not received due to some reason, the sender assumes the frame to be lost and enters the backoff process again to retransmit the previous frame. To reduce the probability of collisions, after each unsuccessful transmission attempt, the contention window is doubled until a predefined maximum value of CW (i.e.  $CW_{max}$ ) is reached. In addition, to improve the channel utilization, the contention window is reset to a fixed minimum value ( $CW_{min}$ ) after each successful transmission.

The Network Allocation Vector (NAV) is used for MAC virtual carrier sensing. Using NAV, a station can estimate the duration in which the medium remains busy thus reducing the possibility of collisions between two stations. Before transmitting a frame, a station has to send Request to Send (RTS) control packet which includes source, destination and time for data transmission. The AP will respond with a Clear to Send (CTS) control packet which includes the same transaction time information. All the stations receiving either RTS or CTS will update their NAV timer, for the given duration.

### III. IEEE 802.11(E) ENHANCED STANDARD

Similar to legacy 802.11, 802.11e has also two modes of operations. One is for contention free, and other for contention based medium access. Hybrid Coordination Function is used during Contention Free Period (CFP) and Enhanced Distributed Coordination Function (EDCF) for handling medium access in Contention Period (CP). EDCF is now called Enhanced Distributed Channel Access (EDCA) [10]. This enhanced standard does not suggest any functional changes at physical layer but does have significant changes at Medium Access Control (MAC) layer to enable QoS.

It is clear that EDCA is used only during the Contention Period (CP). During the CP, each Traffic Class (TC) within the stations contends for a Transmission Opportunity (TXOP) independently. A TXOP is defined in [11] as an interval of time when a station has a right to initiate transmission, defined by starting time and the maximum duration. For obtaining TXOP there are two methods: one via the contention based mechanism and it is known as EDCA-TXOPs, and the other by obtaining TXOP via Hybrid Coordination Function (HCF) in controlled channel access and this type is known as Controlled Access Phase (CAP). The duration of TXOP called "TXOPLimit" is limited and depends upon the type of traffic category in use.

Different traffic categories are used with their respective prioritized parameters including Arbitration Inter Frame Space (AIFS), the minimum size of the CW ( $CW_{min}[TC]$ ) and the  $TXOPLimit[TC]$ . AIFS is the period of time during which the medium must be idle before a station may access the channel or decrement the back off of the corresponding TC. This AIFS is similar to DIFS in legacy standard but the difference is that DIFS is constant for all type of traffic categories where as AIFS varies with TC. Smaller  $CW_{min}$  values for high-priority data flows are used to enable them to access medium early.

Back off time calculations are very much similar to legacy 802.11 DCF. EDCA defines a factor called Persistence Factor

(PF) which varies from 1 to 16. PF is used to increase the length of CW whenever the collision occurs. The values of  $CW_{min}$  and AIFS are obtained as follows [12]:

$$newCW[TC] = [(oldCW[TC] + 1) \times PF] - 1 \quad (1)$$

$$AIFS[AC] = SIFS + AIFSN[AC] \times tslot \quad (2)$$

Now PF is usually has a fixed value of 2 making it equivalent to binary exponential back off. All types of traffic are mapped on 4 TCs maintaining four individual queues. Multiple queues with their own timers may lead to a collision. This collision is solved by a virtual scheduler that grants access to the TC with the highest priority and starts a back off for the lower TC as shown in Figure 1. The various priority levels which are defined for all type of traffic are listed in Table 1.

Network Simulator 2 (NS-2) is used as a primary tool for our simulation. NS-2 is well known discrete event based simulator which is widely used to simulate wired, wireless and wired/wireless networks. The simulations were carried out using NS-2.26 as the EDCA patch was built for this version. IEEE DCF model is a built in feature in NS-2.26 but EDCA patch was installed and tuned for this version. This EDCA model is provided by Telecommunication Network Group (TKN) [13] and its implementation is very modular and flexible.

### IV. SIMULATION AND EVALUATION ENVIRONMENT

In our simulation, we have used wired/wireless scenario in NS-2 as shown in Figure 2. Usually we have added wireless and wired stations in pair i.e. when we have increased number of wireless stations in BSS (Basic service set) we have increased equal number of wired stations in wired LAN. The main reason for using wired cum wireless scenario is that NS2.28 doesn't provide infrastructure mode support. The number of wired and wireless stations varies in different scenarios.

The physical and MAC parameters used in the simulations are given in Table 2 and 3 respectively. These values are recommended and being used by different authors [e.g. 14].

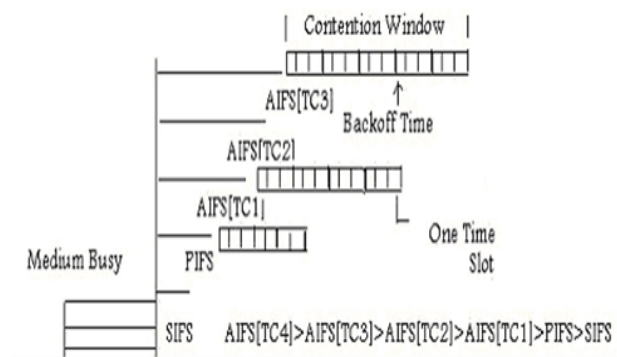

Fig. 1 Different TCs competing for access

TABLE I  
PRIORITY LEVELS MAPPING

Priority	Access Category	Designation
1	0	Best effort
2	0	Best effort
0	0	Best effort
3	1	Video Probe
4	2	Video
5	2	Video
6	3	Voice
7	3	Voice

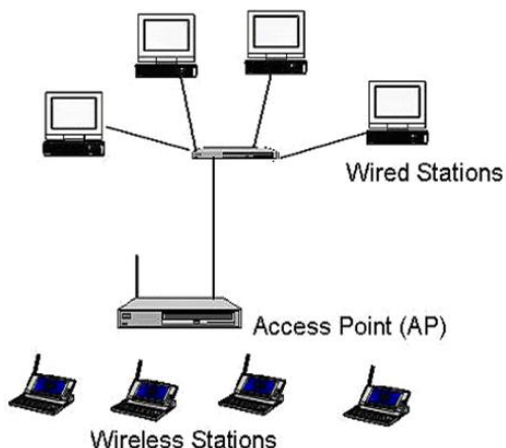

Fig. 2 Simulation Topology

TABLE II  
PHYSICAL LAYER PARAMETERS

Parameters	SIFS (μsec)	DIFS (μsec)	Slot (μs)	CW (min)	CW (max)
802.11 b	10	50	20	31	1023

TABLE III  
PRIORITY SET OF EDCA

Category	TC[0]	TC[1]	TC[3]
AIFS	2	2	3
CWmin	7	15	31
CWmax	15	31	1023
TXOP	3 ms	6ms	0

V. RESULTS AND ANALYSIS

In this section, the differences between IEEE 802.11e EDCA and legacy IEEE 802.11 DCF are highlighted.

A. Effects of MAC Priority Parameters on Medium Access Time

First the differences between EDCA and DCF latencies, and hence the channel access time, with respect to the number of stations are evaluated. In this scenario the number of stations has been increased in sets of three, with maximum number of wireless stations reaching to 21. For EDCA, each set

comprises of one high priority, one medium priority and one low priority traffic station. For DCF, all the stations run on similar priority traffic. The traffic type for all stations for EDCA and DCF is UDP based Constant Bit Rate (CBR) traffic of 200Kbps and packet size of 1000 bytes. The scenario is summarized in Table 4.

TABLE IV  
CHANNEL ACCESS SCENARIO SUMMARY

No. of Wireless Stations	3-21
No. of Wired Stations	3-21
No of Flows/Station	1
Flow Type	CBR
Flow Rate	200Kbps
Packet Size	1000bytes
EDCA Priority Levels	High, Medium and Low
Observed Parameter	Latency

Figure 3 shows that the average time taken by the packets to reach the destination is the least when the packets belong to stations running on high priority traffic. This is followed by medium and low priority traffic stations respectively. It can be inferred that for networks with moderate congestion (around nine stations), the difference between latencies of medium and low priority stations is not substantial (i.e. less than 1.5ms). But as the number of stations reaches 12, a sharp linear increase of about 5ms for each set of stations is observed for low priority traffic. High priority traffic has almost a linear increase with a step of 2ms and even in high congested situation, i.e. when the number of stations has gone past 15, this step does not go beyond 3ms.

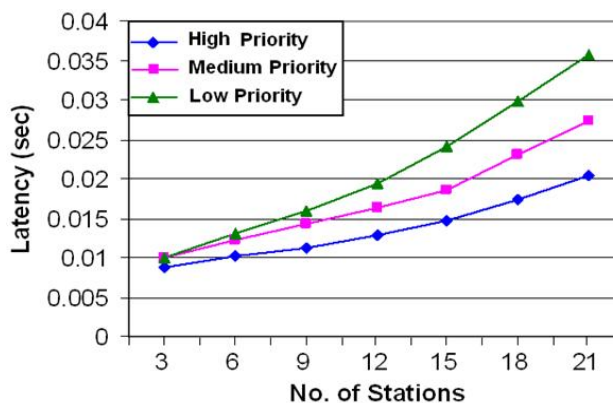

Fig. 3 Average time of packets to reach destination for EDCA

Further, it is observed that in the network with high number of stations the effect of priority parameter is more dominant and clearly affect the sequence of medium access. The delay difference between high and low priority traffic reaches to approximately 80% when there are 21 stations in the network. This clearly shows that all the stations running high priority traffic are served before those stations which are running medium and low priority traffic. This type of behavior is due to different CWmin and AIFS values for high, medium and low priority traffics. Smaller AIFS and CWmin values of

higher priority traffic flow stations (e.g.  $CW_{min} = 7$ ) reduces the number of time slots they have to wait before they can access the channel. Same is true for medium priority traffic stations which have less average time to access the channel than low priority traffic stations. Higher the number of high priority traffic stations, higher is the waiting time for medium and low priority traffic stations to get access to channel for data transmission.

In DCF as there is no parameter to define traffic priority at MAC level, each type of traffic is treated equally and the average time for packets to reach the destination becomes almost the same for all the stations. For verification of this behavior, 21 stations are divided in three groups of 7 stations each. Group 1 consists of stations STA1, STA4, ... , STA19 (i.e. increment of 3). Similarly, the rest of the groups have the following station numbers: Group 2 of STA2, STA5, ... , STA20 and Group 3 of STA3, STA6, ... , STA21. Results shown in Figure 4 reveals that average time remains almost same for each set even in high congested networks with high number of transmitting stations. There is approximately a difference of 3 ms for addition of every set of stations after the number of stations has reached to 6. Smaller difference is observed before number of stations has reached 6 because of very low contention. This indicates that every station has to wait almost same time before it access the channel to send its data.

So it can be concluded that EDCA and DCF exhibit different trend for medium access. In EDCA the stations with high priority traffic access a channel in less time then medium and low priority traffic running stations. Where as in DCF, since there is no concept of priority for channel access, every station is treated equally and waits a constant time before it gets the chance to transmit data. Thus DCF lacks in differentiated channel access procedure which is vital for providing priority service to stations running critical application.

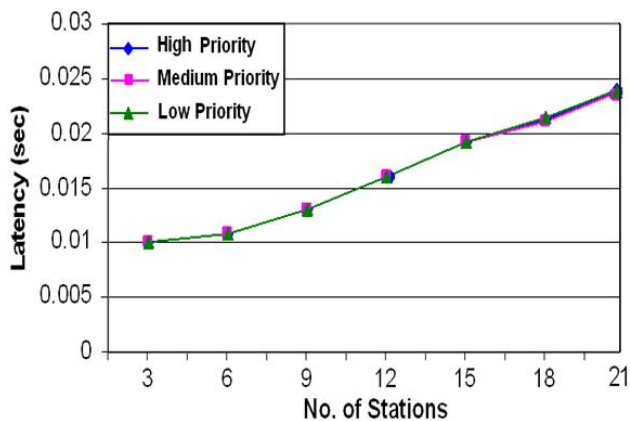

Fig. 4 Average time of packets to reach destination for DCF

### B. Maximum Throughput Analysis

In this scenario only one wireless station and one AP is used. The station is sending data at maximum possible rate i.e.

11Mbps to AP. Maximum throughput is recorded for EDCA with the defined priority levels. Similarly maximum throughput achieved with DCF is also recorded under same scenario. The reason for using single transmitting station is that no contention should be there while recording maximum throughput.

For EDCA, maximum throughput of (5.7, 5.2 and 4.89) MB is achieved for high, medium and low priority parameters respectively as shown in Figure 5. On the other hand, legacy MAC of 802.11 with DCF was able to provide maximum throughput of almost 4.91 MB. This behavior is obvious since for high priority traffic and with small  $CW_{min}$  value and less number of AIFS, the time required to access the medium again after the transmission of a packet is much smaller than the time required by medium and lower priority traffic.

The purpose of this type of analysis is to study how EDCA and DCF serve multimedia and data traffic simultaneously. In this scenario four voice stations, two video stations and four data stations are used at the wireless side. Voice is CBR type traffic with G.711 standard parameter and CBR type with frame size of 1200 bytes and Data rate of 500Kbps. Data type traffic is simple TCP based FTP application with TCP packet size of 1500 bytes and window size 64. This scenario is similar to the one in [14] which is summarized in Table 5.

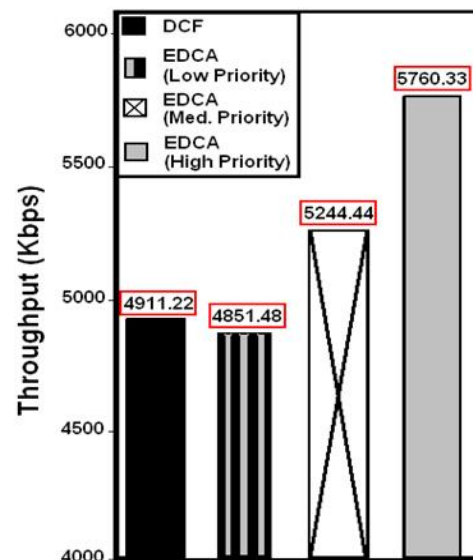

Fig. 5 Maximum throughput achieved by a single station for both DCF and EDCA (Different priority levels)

### C. Service Comparison of EDCA and DCF

By comparing the graphs of the cumulative throughput, latency and the drop ratio, of each traffic type (see Figures 6-8), it can be easily said that EDCA serves multimedia traffic far better than DCF. Since DCF has no priority medium access mechanism, the latencies of voice and video are much higher than EDCA. These latencies are 23ms and 294ms for voice and video respectively with drop ratio reaching up to 4% and 6% respectively.

TABLE V  
SERVICE COMPARISON SCENARIO SUMMARY

No. of Wireless Stations	4 Voice, 2 Video, 4 Data		
No. of Wired Stations	10		
No of Flows/Station	1		
Flow Type	Voice	Video	Data
	CBR	CBR	TCP
Flow Rate	Voice	Video	Data
	64kbps	500kbps	-
Packet Size	Voice	Video	Data
	280	1200	1500
EDCA Priority Levels	Voice	Video	Data
	High	Medium	Low

This clearly suggests that voice has low quality and video has almost no quality in DCF. According to [15], and specifically for video, in order to avoid blocking effects, the time for packets to reach the destination should not go beyond 300 ms and the drop ratio must not get higher than 2 %. Remaining within these specification defined by [15], EDCA serves both video and voice as the drop ratio has not gone above 1% (see Figure 6) and the latencies for voice and video are 8ms and 10ms respectively as shown in Figure 7. Figure 8 indicates an improvement in the uplink and downlink throughput for both voice and video and almost the same throughput for data.

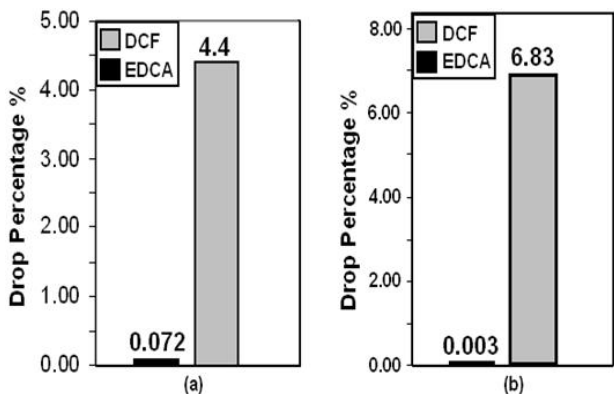

Fig. 6 Uplink drop ratio using EDCA and DCF for: (a) voice (b) video

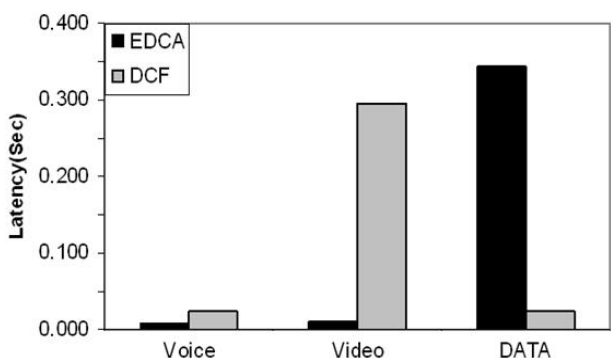

Fig. 7 Uplink latencies using EDCA and DCF for various types of traffic

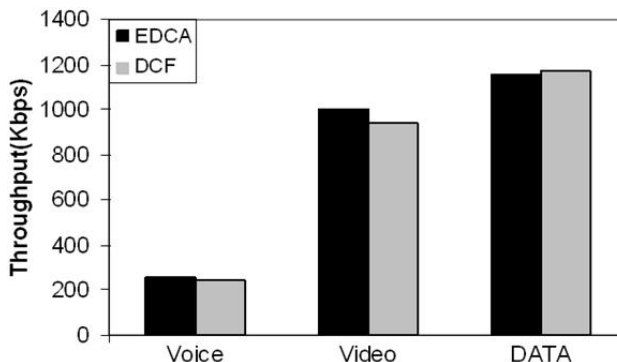

Fig. 8 Uplink throughput using EDCA and DCF for various types of traffic

### VI. FAIRNESS ANALYSIS OF UPLINK AND DOWNLINK THROUGHPUT IN IEEE 802.11(E)

In this section, we emphasize on the throughput fairness issue in both downlink and uplink in IEEE 802.11e networks. By varying  $CW_{min}$  values, better fairness can be achieved as described in the subsequent paragraphs.

#### A. Throughput Fairness Issue

Due to the flow-differentiated access mechanism of IEEE 802.11e, a better performance for multimedia traffic is achieved in comparison with legacy IEEE 802.11. Hence, it is imperative to analyze the performance of 802.11e in terms of the overall uplink and downlink throughput. For this purpose, simulations are carried out by using IEEE 802.11e MAC with data rate of 2 MB and basic rate of 1MB. High priority parameters and bidirectional 64kbps voice connections are used. Results are presented in Figure 9.

It can be observed that till the 6<sup>th</sup> station, and when there is enough bandwidth available to serve both uplink and downlink, fair division of bandwidth is there between uplink and downlink traffic. But as the number of stations increases and the bandwidth requirement for uplink increases, the fairness between uplink and down link reduces and more bandwidth is provided to uplink than downlink. This unfair division of uplink and down link throughput, which is also indicated in some articles e.g. [16] is more noticeable in high congested networks. This is due to the fact that access point uses the same medium access parameters as used by other stations which results in less downlink throughput specially when there are large numbers of users. Since, AP has similar medium access parameter for down link therefore; it has to wait almost the same time as other stations to send its data. This severely reduces the downlink throughput.

#### B. Proposal for Better Fairness between Uplink and Downlink Throughput

Smaller  $CW_{min}$  have been proven effective in providing access to medium in shorter time as indicated in the previous sections. But  $CW_{min}$ , AIFS and TXOP are only defined for traffic flow types and not to individual wireless stations. Hence for a particular flow, the diminished downlink

throughput problem persists. To address this issue, parameters are to be defined for individual stations. An interesting proposition is to use smaller  $CW_{min}$  values on flows (i.e. stations) running on AP compared to the  $CW_{min}$  values for other stations. This methodology grants privileged medium access in less time to downlink flows, which results in an improved throughput fairness between uplink and downlink. To simulate the proposition,  $CW_{min}$  and  $CW_{max}$  for AP are changed to 3 and 7 respectively. Further, simulations are carried out by varying AIFS and TXOP but the results are not presented in this paper as no significant improvement is obtained. Insignificance of AIFS for channel access has been discussed in [12]. Smaller value of  $CW_{min}$  gives less time slots before the medium can be accessed and results in early access of medium by AP compared to other wireless nodes. This improves the downlink throughput considerably.

As shown in Figure 10, this proposed method works fine and has improved the downlink throughput significantly. It can be observed that for small number of stations, downlink has a slightly more throughput than uplink due to frequent medium accesses (i.e. shorter  $CW_{min}$  value). In high congestion situation, number of collisions may increase, which results in larger value of  $CW_{min}$  and thus minimizing downlink throughput.

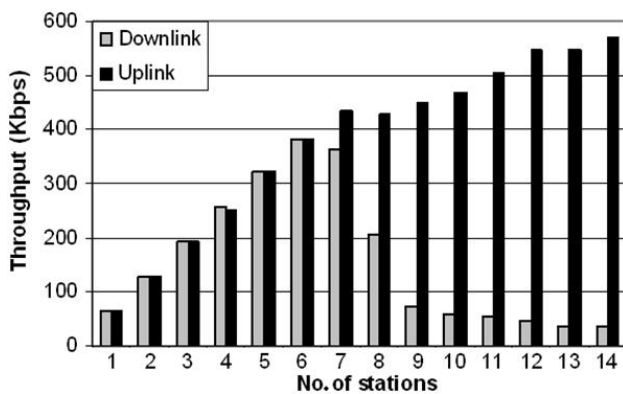

Fig. 9 Unfair uplink/downlink throughput

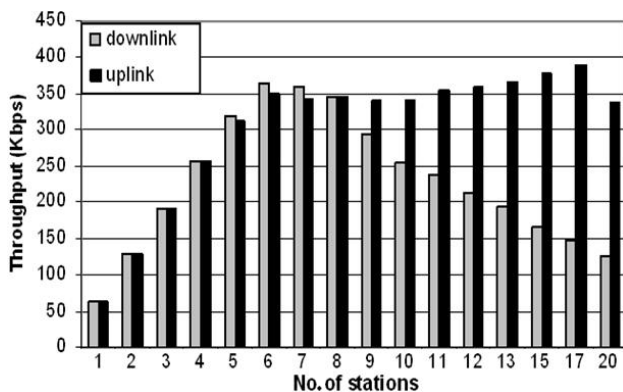

Fig. 10 Enhanced AP for better uplink/downlink throughput

## VII. CONCLUSIONS

By analysing the performances of IEEE 802.11 and IEEE 802.11e, we conclude that EDCA has a better performance than DCF in various ways. This is due to the flow differentiated channel access mechanism of EDCA. This mechanism does not only increase the channel utilization but also provides better QoS for multimedia traffic. On the other hand, DCF fails to provide QoS to any priority traffic. In addition, the problem of unfairness between uplink and downlink throughputs exists in such networks. This problem is tackled by proposing a simple method based on providing privileged medium access to AP which is resulted in a better throughput allocation for both downlink and uplink.

## REFERENCES

- [1] Banchs, A. and Perez X., "Providing throughput guarantees in IEEE 802.11 wireless LAN", in *Proc IEEE WCNC 2002*, Orlando, FL, Mar 2002, vol. 1, no. 17-21, pp. 130-138.
- [2] O'Mahony, D. and Doyle, L., "Architectural Imperatives for 4th Generation IP-based Mobile Networks", invited paper, in *Proceedings of the fourth international symposium on wireless personal multimedia communications*, September, 2001, Aalborg, Denmark, pp 1319-1325.
- [3] Liqiang Zhao and Changxin Fan, "Enhancement of QoS differentiation over IEEE 802.11 WLAN", *IEEE communication. letters.*, vol. 8, no. 8, pp. 494-496, Aug. 2004.
- [4] Bedoui Adel, Barkaoui Kamel and Djouani Karim, "Performance Study of IEEE 802.11 WLAN Integrating QoS Requirements", in *Proc. ICWMC '07*, France, Mar. 2007, pp. 69-69.
- [5] Mico F., Cuenca P. and Orozco-Barbosa, L., "QoS in IEEE 802.11 wireless LAN: current research activities," in *Proc. of IEEE Canadian Conference on Electrical and Computer Engineering 2004*, Ontario, Canada, May 2004, pp. 447-452.
- [6] Ping Wang, Hai Jiang and Weihua Zhuang, "IEEE 802.11e enhancement for voice service", *IEEE Wireless Communications*, vol. 13, no. 1, pp. 30-35, Feb. 2006.
- [7] Yang Xiao, "Packing mechanisms for the IEEE 802.11n wireless LANs", *IEEE GLOBECOM 2004*, Nov-Dec. 2004, TN, USA, vol. 5, no. 29, pp. 3275-3279.
- [8] Bob O'Hara and Al Petrick, "802.11 Handbook: A Designer's Companion", January 1, 2005.
- [9] Youjin Kim, Haewon Jung, Hyeong Ho Lee and Kyong Rok Cho, "MAC implementation for IEEE 802.11 wireless LAN", in *Proc. of Joint 4th IEEE International Conference on ATM (ICATM 2001) and High Speed Intelligent Internet Symposium 2001*. Seoul, South Korea, April 2001, pp. 191-195.
- [10] Zhang wei, Sun Jun, Lui Jing and Zhang Hai-bin, "Performance analysis of IEEE 802.11e EDCA in wireless LANs", *Journal of Zhejiang University - Science A*, vol. 8, no. 1, pp. 18-23, January, 2007.
- [11] "Wireless LAN Medium Access Control (MAC) and Physical Layer (PHY) Specification," *ANSI/IEEE Std 802.11 1999 (E) Part 11*, 1999.
- [12] Casetti C., Chiasserini C. F., Fiore M. and Garetto M. "Notes on the inefficiency of 802.11e HCCA", in *Proc. 62nd IEEE Conference on Vehicular Technology 2005 (IEEE VTC-2005)*, Sept. 2005, Dallas, USA, pp. 2513-2517.
- [13] Sven Wietholter, Christian Hoene, Marc Emmelmann, and Adam Wolisz "TKN EDCA model for ns-2", Technical University Berlin TKN June 2006.
- [14] Magnold S., Choi S., Hiertz G., Klein O. and Walke B., "Analysis of IEEE 802.11e for QoS Support in Wireless LANs," *IEEE Wireless Communications*, vol. 10 (6), pp. 40-50.
- [15] Bai A., Skeie T., and Engelstad P.E., "A Model-Based Admission Control for 802.11e EDCA using Delay Predictions," in *Proc. of IEEE IPCCC 2007*, April, 2007, New Orleans, LA, pp.226-235.
- [16] S. Pilosof. R., Ramjee Y., and Shavitt. P. Sinha, "Understanding TCP fairness over Wireless LAN", in *proc IEEE INFOCOM 2003*, Mar-Apr 2003, San Francisco, USA pp. 863-872.

**Ammar Abbas** obtained MS in Computer System Engineering with specialization in Wireless Networks from the National University of Sciences and Technology (NUST) and BS Engineering from Sir Syed University of Engineering and Technology (SSUET), Karachi, Pakistan. Currently he is associated with SSUET as an Assistant Professor in Computer Engineering department. He is also a member of the final year project committee in SSUET. His research interest includes Quality of Service (QoS) in Wireless and Cellular networks.

**Ibrahim M. Hussain** obtained his MS in Computer Engineering with specialization in Computer Networks from the Sir Syed University of Engineering and Technology (SSUET), Karachi, Pakistan and B.E. in Computer Engineering from N.E.D. University of Engineering and Technology. At present, he is working as an Assistant Professor in the Department of Computer Engineering, SSUET. He is also a member of the final year project committee in SSUET. His research interest includes wireless communication and networks, wireless networks design and signal and image processing. He has number of research publication in international journals and conferences.

**Osama M. Hussain** has received his Bachelors of Science in Computer Engineering and Masters of Science in Computer Networking, both from the Department of Computer Engineering - Sir Syed University of Engineering & Technology, Pakistan. At present, he is working as a Research Assistant in Communication & Information Research Center (CIRC) - Sultan Qaboos University (SQU), Oman. He has also worked as a faculty member in Iqra University (IU) – Pakistan. His research interests includes, fourth generation (4G) wireless communication systems, electromagnetic compatibilities (EMC), wireless networks, ubiquitous computing and signal processing techniques.