

# Experimental Verification and Finite Element Analysis of a Sliding Door System Used in Automotive Industry

C. Guven, M. Tufekci, E. Bayik, O. Gedik, M. Tas

**Abstract**—A sliding door system is used in commercial vehicles and passenger cars to allow a larger unobstructed access to the interior for loading and unloading. The movement of a sliding door on vehicle body is ensured by mechanisms and tracks having special cross-section which is manufactured by roll forming and stretch bending process. There are three tracks and three mechanisms which are called upper, central and lower on a sliding door system. There are static requirements as strength on different directions, rigidity for mechanisms, door drop off, door sag; dynamic requirements as high energy slam opening-closing and durability requirement to validate these products. In addition, there is a kinematic requirement to find out force values from door handle during manual operating. In this study, finite element analysis and physical test results which are realized for sliding door systems will be shared comparatively.

**Keywords**—Finite element analysis, sliding door, experimental, verification, vehicle tests.

## I. INTRODUCTION

FIRST sliding door used in vehicles, Wilbur W. Ellis, patented in 1913. It is similar with current system. Mechanisms carry door by the tracks [1].

The movement of a sliding door on vehicle body is ensured by mechanisms and tracks. There are three tracks and three mechanisms which are called upper, central and lower on a sliding door system. Sliding door systems include steel, plastic and rubber parts which are manufactured by cold and hot forming processes.

The Finite Element Method has been used increasingly for the analysis of engineering applications. Despite the development of easy-to-use finite element programs, it is difficult to create a good model that enables a realistic analysis of the physical processes involved in a real project and that provides a realistic prediction of design quantities (i.e. displacements, stresses, structural forces, bearing capacity, safety factor, etc.) [3]. Finite element analysis is used as a first design validation step of a sliding door system. Finite element analysis need to CAD data and well defined boundary conditions as the inputs. CAD data is finalized by design engineers during the design process. System requirements of a sliding door help about boundary conditions of finite element analysis. The other important design validation step of a sliding door system is physical tests. The results from finite element analysis and physical tests must be corresponded.

C. Guven, M. Tufekci, E. Bayik, O. Gedik, M. Tas are with the Rollmech Automotive San. ve Tic. A.S., Bursa, 16140 Turkey (phone: +90 549 800 04 72, +90 549 800 04 89, +90 549 800 04 71, +90 549 800 04 77, +90 549 800 04 40; fax: +90 224 243 87 67; e-mail: caner.guven@rollmech.com, mustafa.tufekci @rollmech.com, emir.bayik @rollmech.com, ozgur.gedik @rollmech.com, mustafa.tas @rollmech.com).

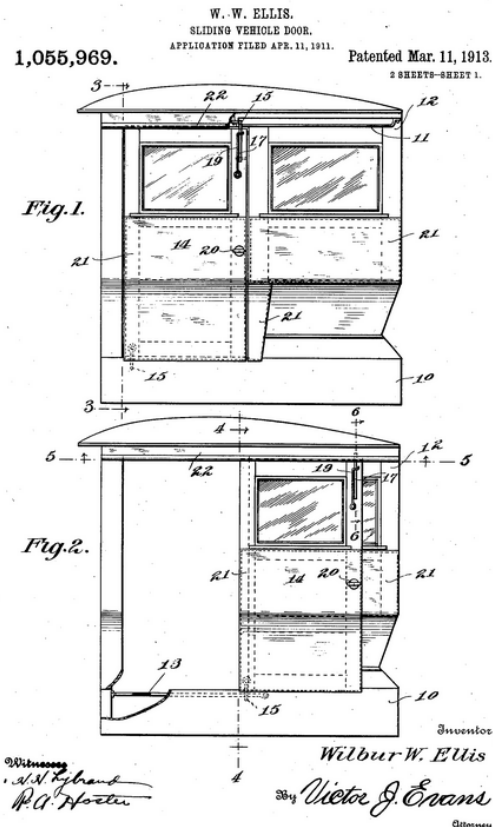

Fig. 1 First sliding door patent [2]

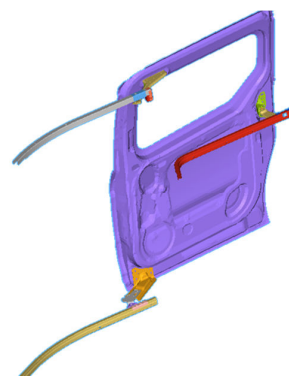

Fig. 2 Sliding door system

## II. VALIDATION PROCESS WITH RESULTS

Illustrated process in Fig. 3 is the validation method for design of sliding door system. A sliding door system's design must ensure a lot of requirements. Some of these requirements listed below.

- Manual Operating Effort
- High Energy Slam
- Door Drop Off
- Door Stiffness
- Mechanism Stiffness
- Durability
- Packaging

It is very important to catch design failures with finite element analysis. Otherwise validation process takes longer time. If a design failure is caught with physical tests after prototype manufacturing, validation process repeats.

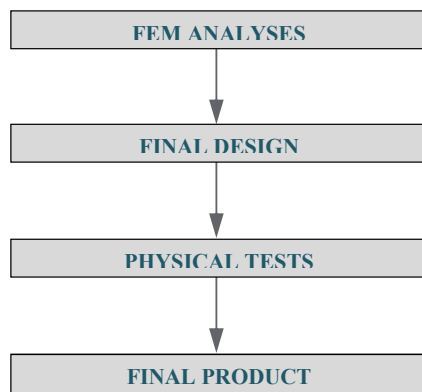

Fig. 3 Validation process

### A. Manuel Operating Effort

The maximum manual operating efforts of the sliding door must be less than the effort profile defined requirement. Kinematic model is prepared with Hyperworks Motionview. All parts of sliding door system are imported to Motionview with their mass, center of gravity and inertia information. Degrees of freedom of mechanisms are ensured by joints. Center of gravity and handle point of door are determined for analysis. Door is opened with the constant velocity. Final kinematic model is solved by Hyperworks Motionsolve. Effort results are calculated for door handle. Kinematic model of a sliding door is seen in Fig. 4. Test and analysis results for manual operating effort of a sliding door are shared in Table I comparatively.

### B. High Energy Slam

This requirement simulates motion of sliding door under gravity on an incline of 30% grade. For slamming the door open, the door must be allowed to free fall from a position from full closed to full open by unlatching. For slamming the door close, the door must be allowed to free fall from the full open to full close position. After completion of the test, the door must still pass other functional requirements.

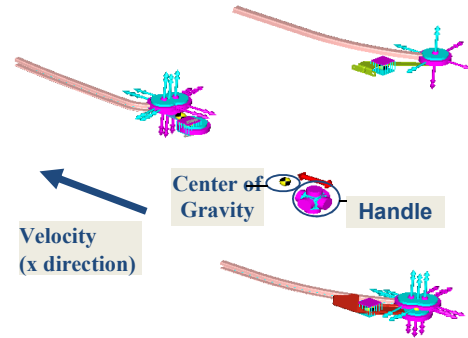

Fig. 4 Kinematic sliding door model

TABLE I  
EFFORT RESULTS FROM TEST AND FEA

	Curve Section Opening	Linear Section Opening	Linear Section Closing	Curve Section Closing
FEA	37,00 N	20,00 N	4,00 N	-19,00 N
Test	33,08 N	14,9 N	0,00 N	-13,09 N

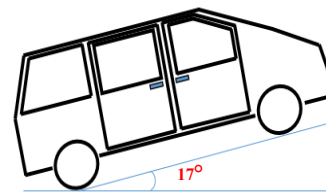

Fig. 5 High energy slam opening requirement [1]

FEA model is prepared as the sliding door is nearly to complete its motion. For high energy slam opening analysis, it is modeled at the end of the track. Analysis starts from beginning of impact with initial velocity which is calculated from conservation of energy or measured with physical test. Mechanisms crash the rubber bumpers at the end of the track. Stress and strain values are obtained as the results of the analysis to observe damage of the parts.

Door velocity, depends on the tracks length, arrives 10 km/h. Therefore, high energy slam is one of the most difficult requirements for sliding door system. Damage examples are shown in Fig. 6 and in Fig. 7 about high energy slam requirement comparatively from test and analysis.

### C. Door Drop Off

The drop-off of the full trimmed sliding door must not exceed limit defined with requirement under the door's own weight. Displacement results of door drop off analysis and test are shared in Table II. Displacement distribution of a sliding door according to door drop off analysis is shown in Fig. 8.

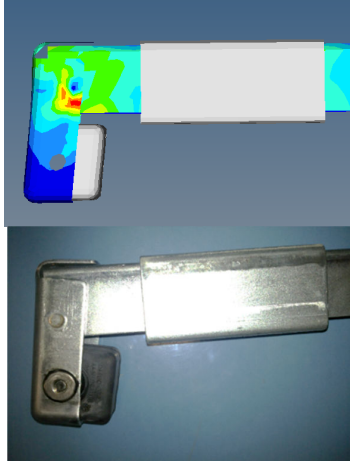

Fig. 6 Corresponded plastic deformation of bracket

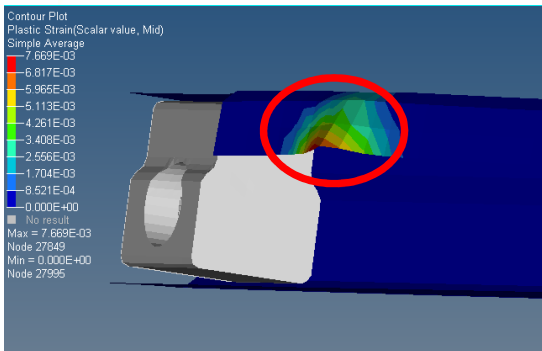
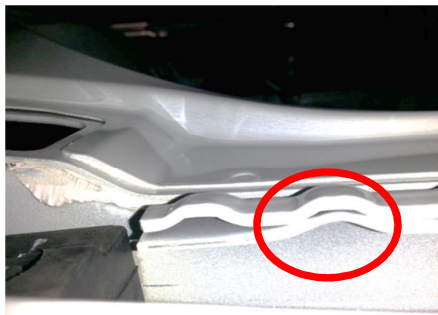

Fig. 7 Corresponded plastic deformation of track

**D. Door Stiffness**

For door stiffness requirements, test and analysis are realized at fully opened position and partially opened position. There are 14 different situations about stiffness requirement with;

- different door positions,
- different force values,
- different force direction,
- different applied points.

The door shall not disengage from the tracks when the load is removed door must remain functional. Disengagement and functionality are evaluated with stress and strain results of the finite element analysis.

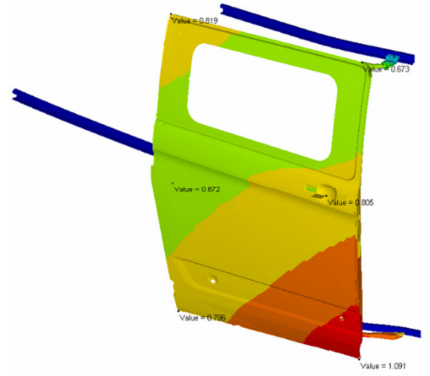

Fig. 8 Door drop off displacement results

TABLE II  
DISPLACEMENT RESULTS FROM TEST AND ANALYSIS

Results	Ajar Position Displacement	Open Position Displacement
Analysis	1,291 mm	1,360 mm
Test	1,800 mm	1,920 mm

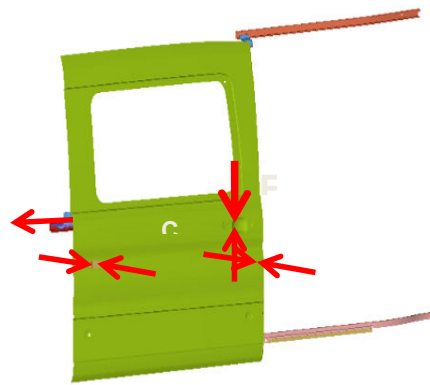

Fig. 9 Stiffness requirement load directions

**E. Mechanism Stiffness**

Door weight affects directly mechanisms over the contact between carrying rollers of mechanisms and tracks. This requirement is an easy way to find out robustness of the mechanisms. Force is applied to carrying roller. Stress, strain and displacement results are obtained with stiffness analysis.

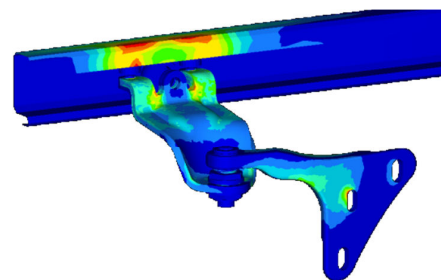

Fig. 10 Stress distribution of track and mechanism from stiffness analysis

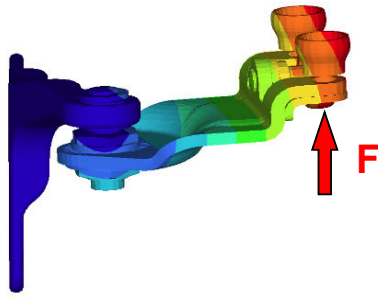

Fig. 11 Displacement distribution and force direction [4]



Fig. 12 Physical test set up for mechanism stiffness

Physical test is realized for this requirement. Displacement results of stiffness analysis which is realized for an upper mechanism, is shared in Table III comparatively [5].

TABLE III  
DISPLACEMENT RESULTS FROM TEST AND ANALYSIS

Results	Displacement from Test	Displacement from CAE
Specimen No 1	2.90 mm	2.97 mm
Specimen No 2	3.38 mm	2.97 mm
Specimen No 3	3,55 mm	2.97 mm

#### F. Durability

Durability is a very important requirement about performance of a sliding door. This requirement realized as a physical test in a climatic chamber with variable conditions which are depends on sliding door type. Requirement variables are cycle, opening speed, closing speed, temperature, moisture.

After completion of the test, the door must still pass the fit-finish requirement, the opening effort requirement, the closing effort requirement, the squeak and rattle requirement, and the door closing sound quality requirement. In addition, there shall be no sheet metal cracks, signs of discoloration, fracturing, or loosening of attachments.



Fig. 13 Part fails from durability test [6]

#### G. Packaging

Minimum clearances are checked with kinematic analysis during the motion of the sliding door.

### III. CONCLUSION

Experimental verification and finite element analysis of a sliding door system used in automotive industry was studied. Finite element analyses and physical tests were realized according to requirements.

Firstly, designing a sliding door system without a failure is aimed. Then if there is a design failure, it is better to see it with finite element analysis than physical tests. The worst situation is to see the failures with physical tests on the prototypes from the point of validation process.

Developments about sliding door design validation process are continuing related to our testing and analysis capabilities. Measurements of new parameters (stress, strain, residual stress, etc.) with physical tests ensure to compare more parameters between tests and analysis. It helps about correlation and accuracy of finite element analysis. Fatigue and durability are the main topics of our studies. These studies are very important from point of design life and customer satisfaction.

### REFERENCES

- [1] C. M. Uzundere, Ö. Karakoç, "Bir Taşıt Kayar Kapı Mekanizmasında Ayarlanabilir Kapı Durdurucu," 7th Automotive Technologies Congress, Bursa, May 2014.

- [2] W. W. Ellis, "Sliding Vehicle Door", 1913, United States Patent Office, Patent Number: 1055969, 11.03.1913.
- [3] R.B.J. Brinkgreve, E. Engin, "Validation of geotechnical finite element analysis", Proceedings of the 18th International Conference on Soil Mechanics and Geotechnical Engineering, Paris, 2013.
- [4] Ö.S. Ömür, C. Rakipsiz, H. Şengünalp, "B-Sütunsuz Binek Araçlarda Kayar Kapı Tasarımı," 7. Otomotiv Teknolojileri Kongresi, Bursa, May 2014.
- [5] C. Güven, Rollmech Automotive Mechanism Stiffness Analysis Report, Rollmech Automotive, Bursa, 2015.
- [6] E. Bayik, Rollmech Automotive Durability Test Report, Rollmech Automotive, Bursa, 2015.