

Evaluation of Structural Behavior of Wide Sleepers on Asphalt Trackbed Due to Embedded Shear Keys

Seong Hyeok Lee, Jin Wook Lee, Bu Seog Ju, Woo Young Jung

Abstract—Korea Train eXpress (KTX) is now being operated, which allows Korea being one of the countries that operates the high-speed rail system. The high-speed rail has its advantage of short time transportation of population and materials, which lead to many researches performed in this matter. In the case of high speed classical trackbed system, the maintenance and usability of gravel ballast system is costly. Recently, the concrete trackbed structure has been introduced as a replacement of classical trackbed system. In this case, the sleeper plays a critical role. Current study investigated to develop the track sleepers readily applicable to the top of the asphalt trackbed, as part of the trackbed study utilizing the asphalt material. Among many possible shapes and design of sleepers, current study proposed two types of wide-sleepers according to the shear-key installation method. The structural behavior analysis and safety evaluation on each case was conducted using Korean design standard.

Keywords—Wide Sleepers, Asphalt, High-Speed Railway, Shear-key.

I. INTRODUCTION

RECENTLY the concrete sleeper is commonly used in the current rail structure, while the classical wood sleeper had been mainly used for railway sleepers in the past. In the case of classical ballast, it has been now being replaced to the concrete trackbed. The classical ballast track structure has been widely used as the track structure in world wide. The wheel road typically transferred to the trackbed through the rail and the sleeper, and this load is being distributed through the friction point of trackbed area. In the case of classical structure, the safety of railway is maintained by the friction force between gravel and gravel, as the elasticity of railway system absorb the impact and vibration. However, this structure gradually being destructed by the train-load, therefore the decrease of elasticity can lead to the deformation of track structure, and twisting of track structure. Also, it causes some typical problems such as increases the maintenance cost, decrease of railway ability, and decrease of comfortableness. In order to overcome the shortcomings, the concrete trackbed structure has been introduced [1]. However the concrete trackbed structure, in fact, has high initial construction cost [2]. Therefore, many researches are being conducted to develop a slab trackbed

system using an asphalt material [3]-[5]. This system has relatively low initial construction cost in comparison to concrete system, and lower maintenance after the construction due to the increased structural stiffness, and eventually increase the comfortable seating to passengers. The primary objective of the current study is to develop a super structure readily applicable to asphalt trackbed system. A structural design of two different types of PC wide sleeper according to the shear key installation method, as well as the usability evaluation are investigated. ABAQUS software package [6] is used by the numerical technique to analyze the proposed structures and several previous numerical researches for structural analysis are considered in this study [7]-[10].

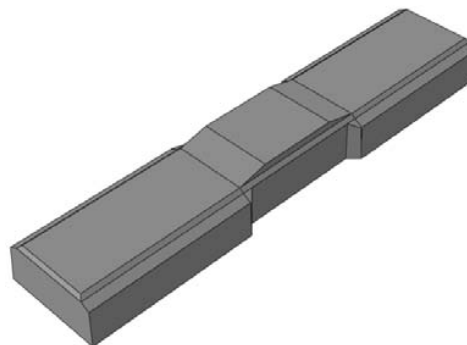

Fig. 1 Design of wide sleeper for internal embedded shear-key

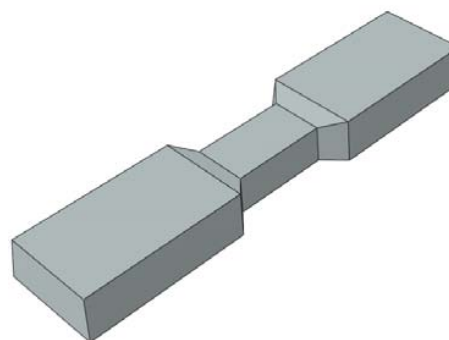

Fig. 2 Design of the wide sleeper for external embedded shear-key

II. STRUCTURAL ANALYSIS OF A WIDE SLEEPER ON ASPHALT TRACKBED SYSTEM

A. Definition of a Wide Sleeper

A wide sleeper is one kind of concrete sleeper, and it possesses the advantage of concrete sleeper. This sleeper system increases the friction force of trackbed foundation, and

S.H. Lee is with High-speed Railroad Systems Research Center, Korea Railroad Research Institute, Korea (e-mail: shlee@krrri.re.kr).

J.W. Lee is with High-speed Railroad Systems Research Center, Korea Railroad Research Institute, Korea.

B.S. Ju is with Institute for Disaster Prevention, Gangneung -Wonju National University, Gangneung, Korea.

W.Y. Jung is with the Department of Civil Engineering, Gangneung -Wonju National University, Gangneung, Korea (corresponding author e-mail: woojung@gwnu.ac.kr).

increase the loading area of train load, which effectively distribute the intensity of railway load to the trackbed by having larger loading area.

B. Comparison of Design of Wide Sleepers

The side sleeper model can be classified into two groups according to the shear-key installation method. First sleeper, the sleeper shape designed in the early stage, as shown in Fig. 1, contained the concrete shear key, and the center of the sleeper is mounted due to the presence of shear key inside the sleeper. The second sleeper, the sleeper shape designed to have installable external shear key, rather than internal shear key inside the sleeper, in order to reduce the damage of concrete element classified by the presence of shear key inside. As shown in Fig. 2.

C. Design Load and 3D Finite Element Modeling

The trackbed system is composed of trackbed foundation, asphalt sub-grade, and wide sleeper as a super structure. Depending on the function of the system, the rail and the sleeper is being connected using a spring model during the finite element modeling. The trackbed foundation model is developed using a calculated value from ground spring model. Fig. 3 showed the 3D finite element models of Figs. 1 and 2, respectively. The dimensions and material properties of structure used for each model can be found in Tables I and II, respectively. In the case of elastic modulus of asphalt, the extreme temperature in summer season, considering the critical design condition, is selected for elastic modulus of asphalt, as its material properties depends heavily on the temperature.

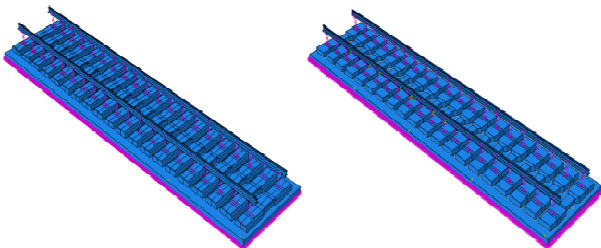

Fig. 3 Finite element model of case 1 and case 2

TABLE I
DIMENSION OF THE WIDE SLEEPER ON ASPHALT TRACKBED SYSTEM

Type	Shape	Value
Concrete Sleeper Case1	Length	2400mm
	Width at the end of the side	500mm
	Width at the center	400mm
	Surfcae width	360mm
	Height	180mm
Concrete Sleeper Case1	Length	2400 mm
	Width at the end of the side	500 mm
	Width at the center	293 mm
	Surfcae width	460 mm
	Height	180 mm
Asphalt layer	Lenth	12625 mm
	Width	3000 mm
	Height	200 mm
Rail (UIC 60)	Length	12625 mm

TABLE II
MATERIAL PROPERTIES OF ASPHALT TRACKBED SYSTEM

Type	Elastic Modulus (MPa)	Poisson's Ratio	Density(t/mm ³)
Sleeper	31928	0.2	2.452e-9
Rail	200000	0.3	7.6e-9
Asphalt	2000	0.3	2.3e-9
Ground Spring		0.1717N/mm	

The design load considered in this research was KTX, using the most recent design standard for train loading (KRL-2012) specified in South Korea. The loading distribution can be found in Fig. 4. The analysis was performed based on the assumption that the actual train load transmitted from rail to the sleeper applied as the distribution load. The design velocity of the train was set as 300km/h, which was appropriate for high speed train. The dynamic modification factor for high speed train was calculated based on (1), as suggested by Korea Rail Network Authority.

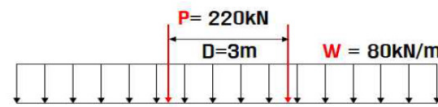

Fig. 4 Train load of KRL-2012

$$DAF \text{ (Dynamic Amplitude Factor)} = 1 + t \times \left(1.0 + 0.5 \frac{V - 60}{190} \right) \quad (1)$$

where DAF : Dynamic modification factor

t : Standard deviation modification factor

\emptyset : Trackbed factor

V : Train velocity (km/h)

III. ANALYSIS RESULTS

This study conducted a comparison of stress distribution occurring at the sleeper with different shape (Case 1 and Case 2). Due to the train loading, the load was distributed to the both ends of the sleeper, and the longitudinal tensile stress occurring at the sleeper was the greatest at the place where the rail was being placed. Figs. 5 and 6 showed the analysis result from Case 1, and Figs. 7 and 8 showed the analysis result from Case 2. As shown in both analysis results, the flexural and tensile stress of positive moment occurred at the loading point of rail.

Table III represented the magnitude of tensile stress. Case 1 possessed sufficient width and thickness due to the shear-key installed inside. Case 2 was designed to slip at the stress deconcentration point at the center part, because of the external shear-key installation. As a result, the tensile stress occurring at the loading area was not different between Case 1 and Case 2. When the shape changes from deflection, however, Case 2 deformed into W-shape, in that the stress concentration occurred relatively excessive, which it was caused by the decrease of the cross section at the center of the sleeper.

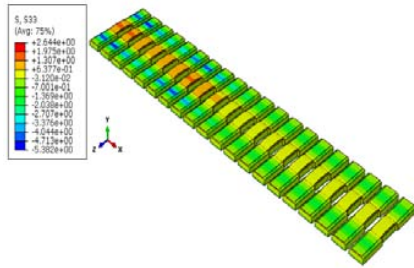

Fig. 5 Surface stress distribution of case 1

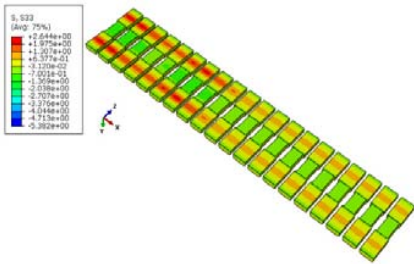

Fig. 6 Bottom stress distribution of case 1

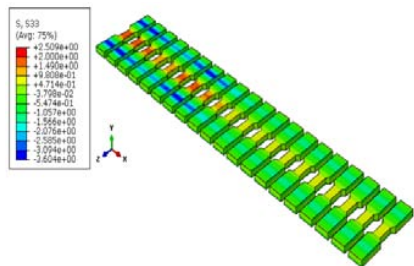

Fig. 7 Surface stress distribution of case 2

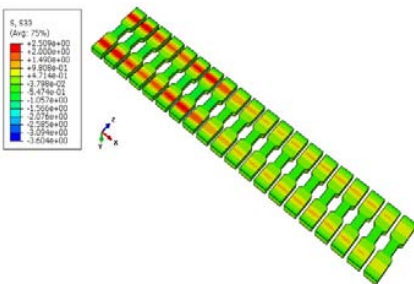

Fig. 8 Surface stress distribution of case 2

TABLE III
TENSILE STRESS ASSOCIATED WITH THE LOCATION

Type	Rail	Sleeper
Case1	2.434 MPa	1.411 MPa
Case2	2.506 MPa	1.950 MPa

A comparison of normal stress distribution at the asphalt layer was performed in order to determine the difference between concrete and asphalt layer. Figs. 9 and 10 showed the normal stress distribution of asphalt layer at each Case, respectively. Table IV represented the magnitude of maximum

compressive stress.

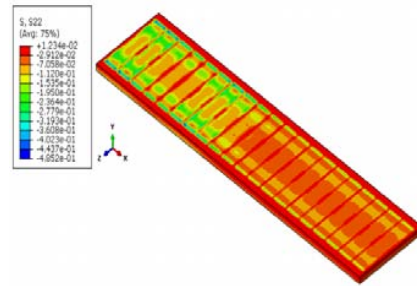

Fig. 9 Normal stress distribution of asphalt trackbed system for case 1

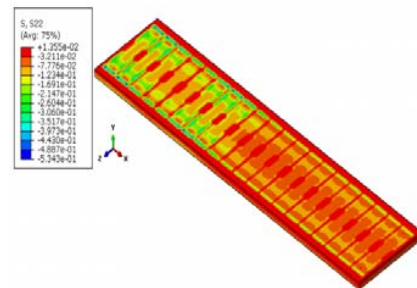

Fig. 10 Normal stress distribution of asphalt trackbed system for case 2

As seen in Case 1, the central portion of railway at the bottom has wide enough width, which allows the relatively larger area than case 2. This could have led to the superior energy dissipation capacity on stress distribution of case 1 sleeper. However, this result only considered the aspect of structural performance. Therefore the further analysis should be conducted with consideration of economic and practical aspects.

TABLE IV
MAXIMUM COMPRESSIVE STRESS ON ASPHALT TRACKBED SYSTEM

Type	Case1	Case2
Normal compressive stress	0.485 MPa	0.534 MPa

IV. CONCLUSION

Current study conducted the analytical study of structural behavior on two types of wide sleeper, applicable to asphalt trackbed system. As a result, the flexural stress and tensile stress occurred at the same site as in Case 1 and Case 2. The flexural stress and tensile stress of Case 1 was larger than that of case 2. In particular, it was found that the flexural stress and tensile stress at the central portion in the railroad at case 2 was much larger than what was found in case 1. It turned out that the surface area of central portion of Case 1 was relatively wider than that of case 2, therefore the stress loaded to asphalt layer was being distributed much efficiently in Case 1.

In future study, the redesign of RC sleeper to PC sleeper in order to reduce the tensile stress at the sleeper should be conducted. In the case of analytical study, the evaluation and analysis using visco-elasticity model rather than elastic model must be conducted.

ACKNOWLEDGEMENT

This research was funded by Korea Railroad Research Institute, Commissioned as part of asphalt trackbed technology and development project in 2014.

REFERENCES

- [1] Ji Jang, *Effect on Dynamic Behavior of Railway Bridge according to Ballast Track Stiffness*, Master dissertation, Seoul National University of Science and Technology, 2007
- [2] SB Seo, *Fundamentals of Track Dynamics*, Yeongdeungpo-gu, Seoul, Korea: Book gallery, 2009, ch8-10
- [3] WYJung, SHLee, JWLee, and BSJu, "Behavior of Concrete Slab Track on Asphalt Trackbed Subjected to Thermal Load", *International Journal of Civil, Architectural, Structural and Construction Engineering (World Academy of Science Engineering and Technology)*, Vol.7, No10, pp.458-463, 2013
- [4] WYJung, SHLee, JWLee, and BSJu, "Analytical Study of the Vibration Attenuation with respect to Trackbed Systems", *International Journal of Railway(The Korean Society of Railway)*, Vol.7, No2, pp.40-45, 2014
- [5] WYJung, SHLee, JWLee, and BSJu, "Analytical Study of the Wide Sleepers on Asphalt Trackbed in Consideration of Nonlinear Contact Condition", *International Journal of Engineering and Technology (Engg Journals Publication)*, Vol.5, No4, 2013
- [6] ABAQUS , Ver.6.13,DassaultSystemes
- [7] JS Kim, WYJung, MH Kwon, "Dissipation of Higher Mode using Numerical Integration Algorithm in Dynamic Analysis", *International Journal of Civil, Architectural, Structural and Construction Engineering (World Academy of Science Engineering and Technology)*, Vol.7, No2, pp.13-20, 2013
- [8] WYJung, MH Kwon and BSJu, "Structural Safety Evaluation of Zip-Line Due to Dynamic Impact Load", *International Journal of Civil, Architectural, Structural and Construction Engineering (World Academy of Science Engineering and Technology)*, Vol.7, No10, pp.91-93, 2013
- [9] WYJung, MH Kwon and BSJu, "The Flexural Improvement of RC Beams Using an Inserted Plate between Concrete and FRP Bonding Surface", *International Journal of Civil, Architectural, Structural and Construction Engineering (World Academy of Science Engineering and Technology)*, Vol.8, No6, pp.182-186, 2014
- [10] WYJung, MH Kwon and BSJu, "Prediction of Nonlinear Torsional Behavior of High Strength RC Beams", *International Journal of Civil, Architectural, Structural and Construction Engineering (World Academy of Science Engineering and Technology)*, Vol.8, No6, pp.176-181, 2014