

Energy Management System in HEV Using PI Controller

S. Saravanan, G. Sugumaran

Abstract—Nowadays the use of Hybrid Electric Vehicles (HEV) is increasing dramatically. The HEV is mainly dependent on electricity and there is always a need for storage of charge. Fuel Cell (FC), Batteries and Ultra Capacitor are being used for the proposed HEV as an electric power source or as an energy storage unit. The aim of developing an energy management technique is to utilize the sources according to the requirement of the vehicle with help of controller. This increases the efficiency of hybrid electric vehicle to reduce the fuel consumption and unwanted emission. The Maximum Power Point Tracking (MPPT) in FC is done using (Perturb & Observe) algorithm. In this paper, the control of automobiles at variable speed is achieved effectively.

Keywords—Batteries, Energy Management System (EMS), Fuel Cell (FC), Hybrid Electric Vehicles (HEVs), Maximum Power Point Tracking (MPPT).

I. INTRODUCTION

RAPID increase in population, energy consumption, increasing oil and natural gas prices, and the depletion of fossil fuels are justifiable reasons for using a hybrid electric vehicle (HEVs) instead of fossil-fuel vehicles [1]. The interest in developing the HEVs with clean and renewable energy sources as a replacement of fossil-fuel vehicles have therefore steadily increased. The HEVs have been proposed as a potential and attractive solution for transport applications to provide environment friendly operation with the use of clean and renewable energy sources [2]. The FC is operated at rapidly changing environmental conditions. Since the FC performs a nonlinear voltage-current curve, its maximum power point (MPP) must be tracked. A major challenge in using FC system is to tackle its nonlinear characteristics. In order to utilize the FC power the term MPPT (Maximum Power Point Tracker) technique is employed. As these quantities vary with time, it is essential to develop a maximum power point tracking (MPPT) algorithm to extract maximum power from the FC module in real time. Over the past decades, many MPPT algorithms have been proposed such as, hill climbing method, perturb and observe (P&O) method, incremental conduction method etc. In this paper, P&O technique is used as it is easy to implement and its cost is less.

This paper is focused on simulation of hybrid electric vehicle power and propulsion systems. The different electrical elements include such as DC/DC converters, Fuel Cell, battery and Ultra Capacitor. Power electronic converters are modeled through nonlinear averaging techniques to give an effective

solution with the accuracy and speed of simulation for large signal analysis. Thereafter, a simulation platform is developed in MATLAB/Simulink for system-level studies of hybrid electric vehicles. As a case study, a hybrid electric vehicle is simulated in different modes of operation. The simulation results of a power sharing control among a fuel cell unit, and an energy storage system show the practical utility of such a controller tool in system studies associated with design, evaluation, power management, etc. HEV has capacity to store the high efficient energy. This energy is typically stored in batteries, Ultra Capacitors (UCs). Fig. 1 shows the overview of three sources for the energy management system in hybrid electric vehicle.

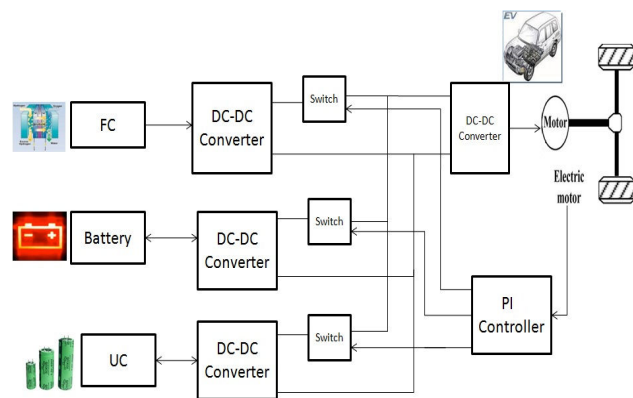

Fig. 1 Proposed System of a hybrid electric vehicle

II. MODEL OF HYBRID ELECTRIC VEHICLE

There are three sources of proposed HEV they are FC, Battery and Ultra Capacitor.

A. Fuel Cell

Fuel Cells produce direct current electricity using an electromechanical process similar to battery. As a result, combustion and the associated environmental side effects are avoided. The fuel cell has received a great deal of attention recently, because of its property of zero emission of greenhouse gases and high power density, also have certain unique features such as high efficiency, diversity of fuels and reusability of the exhaust heat. Proton Exchange Membrane fuel cell is used in the proposed work and in order to have an output voltage around 120 V at no load condition, one fuel cell stacks, with the voltage rating of 24 V each with the voltage profile of 42 V at '0' A and 35 V at '1' A, are connected to the DC bus.

When the fuel cell is delivering power, the flow rate controller of the fuel cell is adjusted to control the hydrogen

supply to fuel cell based on the command from the energy management controller to generate the necessary power to meet the load demand. FC could be a capable alternative for the power generation in environment pollution free vehicle applications. The FC output electric power is expressed by the following equation [3]:

$$Cons_{fc} = B_{fc} \cdot P_{N-fc} + A_{fc} \cdot P_{fc} \quad (1)$$

where P_{FC} is the output power of FC, P_{N-FC} is the nominal output power, A_{FC} and B_{FC} are the coefficients of the consumption.

B. Battery and UC Modeling

The batteries and UCs represent an SOC dependent voltage. The power constraints, available energy, volume and cost are directly scaled to the mass [4]. The internal resistance calculation is dependent on the energy and voltage.

$$R_{factor} = (R_{int} \cdot E_{max}) / V_{max}^2 \quad (2)$$

The R_{int} for a known amount of battery or UC is determined by

$$R_{int} = (R_{factor} \cdot V_{max}^2) / E_{max} \quad (3)$$

The R_{int} is responsible for voltage fluctuations away from the open-circuit voltage during charging and discharging. The voltage fluctuations allow UCs to handle large amount of energy in passively connected system, which can result in extended battery life.

A battery unit may be short circuited without damaging itself; it would take a certain amount of time to fully discharge all of the stored energy, which depends on the energy capacity of the battery.

C. Control Strategies for EMS

The control strategy is designed to benefit the fast charge and discharge capability of UCs in order to reduce the battery stress due to instantaneous power demands using PI controller.

Fig. 2 shows flowchart of the principle of power distribution between the FC, battery and UCs. The HEV follows this condition during variable speed operation in propulsion of the vehicle. The battery is subjected to a rising power request by load. A low pass filter is applied to the load current diverting sudden power variably to the UCs [5].

The fuel cell gives first priority for propelling the vehicle, because the motor is need of high torque to propel the vehicle. The second priority is given to the battery by using a bidirectional converter. The third priority is given to UC which is used when the load is accelerate high speed the high discharge current carried by ultra capacitor.

The battery and UC are charged by using plug from home power source. The battery and UC are discharged means it is automatically energized the charge from the fuel cell during running condition of the vehicle.

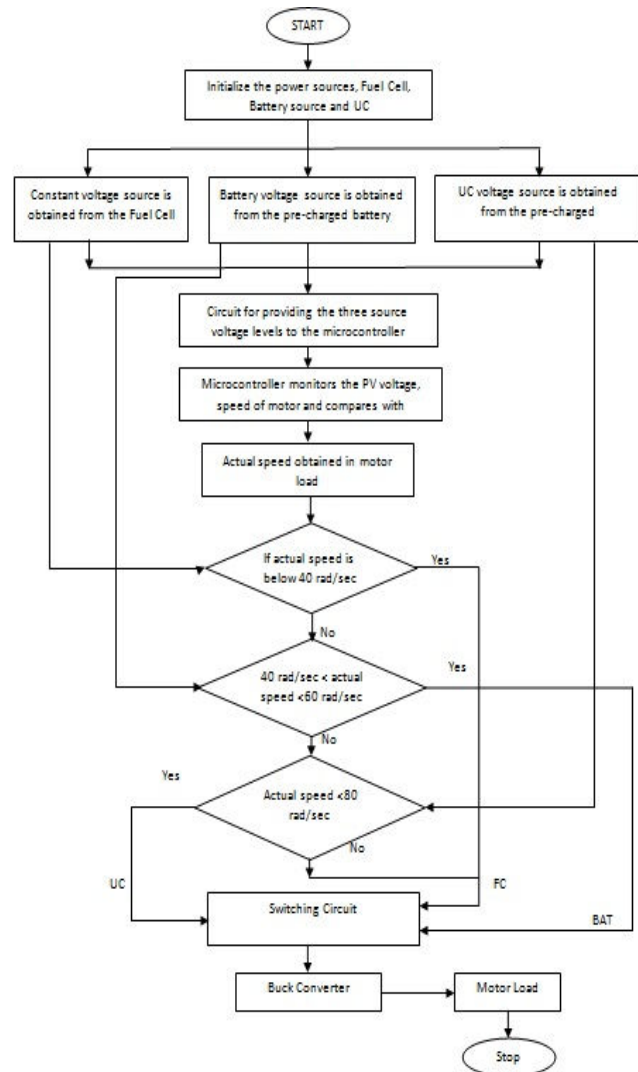

Fig. 2 Control Strategy of a hybrid electric vehicle

D. Bidirectional DC to DC Converter

The circuit of a full bridge bidirectional converter is shown in Fig. 3. High frequency transformer should be necessary in this application where the voltage ratio between LV and HV is high. There is also an additional degree of freedom [6]. The direction of power flow the converter operates in three modes: boost mode, capacitor power mode and capacitor recharge mode. When the DC bus charges the battery or UCs, the power flow direction is reversed which means the energy is transferred from HV side to the LV side under capacitor recharge mode.

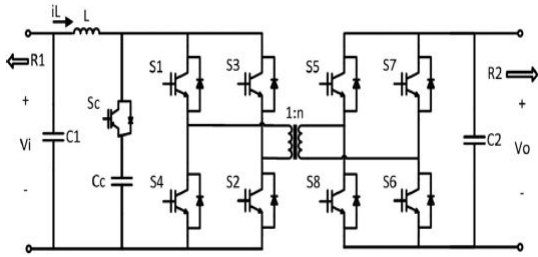

Fig. 3 A full bridge bidirectional converter

E. DC Motor Modeling

The modeling of the permanent magnet DC motor has been carried out with torque and rotor angle consideration. The steady state motor torque T is related to armature current I and a torque constant K .

$$T_m = K I_a \tag{4}$$

The back emf is related to angular velocity by

$$E_b = K \cdot \omega_m = K d\theta/dt \tag{5}$$

F. Perturb and Observe

The P&O algorithm is also called “hill-climbing”, but both names refer to the same algorithm depending on how it is implemented [7]. Hill climbing involves a perturbation on the duty cycle of the power converter and P&O a perturbation in the operating voltage of the DC link the Fuel Cell.

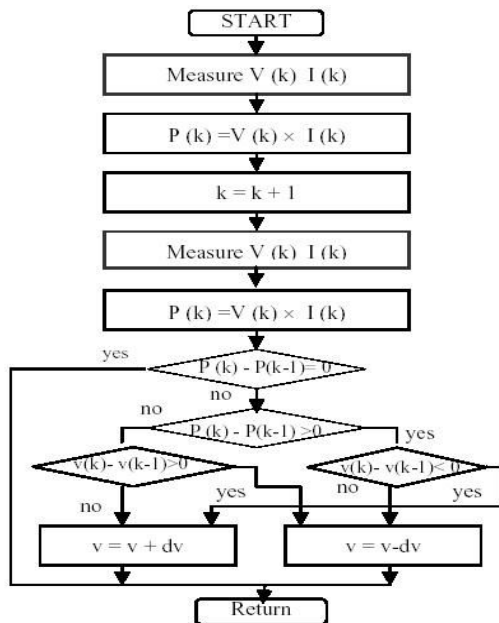

Fig. 4 Flowchart for P&O MPPT Technique

Fig. 4 shows operating point is near to the MPP, the perturbation size is reduced and if the points far, then it is increased. This technique improves the convergence speed and

reduces the oscillation around the MPP. The maximum power obtained in the Fuel Cell is boosted by boost converter. The HEV having the environmental change condition, so P&O is flexible to operate.

III. SIMULATION MODEL

A. Fuel Cell

The fuel cell is used for hybrid electric vehicle is Proton Exchange Membrane Fuel Cell (PEMFC). The fuel cell is generating 24V by using electrochemical process. The output of the fuel cell is given to the boost converter Fig. 5. The boost converter is used to step up the voltage to DC bus voltage. This was modeled using the Sim Power System blocks in the MATLAB library.

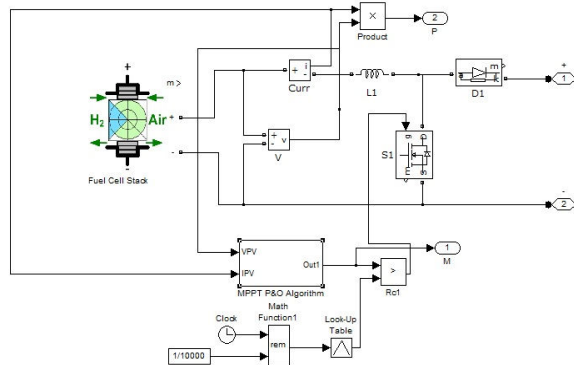

Fig. 5 PEMFC with boost converter

The MPPT unit for this method utilizes the power and the voltage values instead of the current and voltage values as in P&O method. The repeating sequence being utilized in the model has an operating frequency of 10 KHz. This is also the frequency of the gating signal.

B. Model of EMS in HEV

The proposed HEV system is having an energy management system. The control strategy is given for FC, battery and UCs [8]. The output power of the buck converter makes the comparables with referent power. If the speed varies below or above the condition is given in the flowchart then the PI controller will generate the gate pulse to bidirectional converter.

The FC, battery and UCs are connected in a DC bus [9]. So the HEV will operate in every environmental condition. The speed and current of the 5HP DC motor is sensed and according to that the pulse is generated for the buck converter.

The FC has used the P&O MPPT technique. The output of FC is around 24V it is boosted to 120 V using boost converter. The MPPT technique is used to generate pulses for the boost converter for fuel cell.

The output of the bus 120V is capable for the DC bus voltage. The components of the Simulink model are tabulated below:

TABLE I
COMPONENTS OF HEV

Components	Rating
Fuel Cell	PEMFC, 24V
Battery	Li-ion, 24V
Ultra Capacitor	12F
DC motor	5HP, 240V

Li-ion = Lithium ion, V = Volt, F = Farad, HP = Horse Power, PEMFC = Proton Exchange Membrane Fuel Cell

C. Model for Bidirectional Boost Converter

The DC/DC bidirectional converter topologies and their controller are designed and investigated by using MATLAB/Simulink. Fig. 6 shows the bidirectional boost converter.

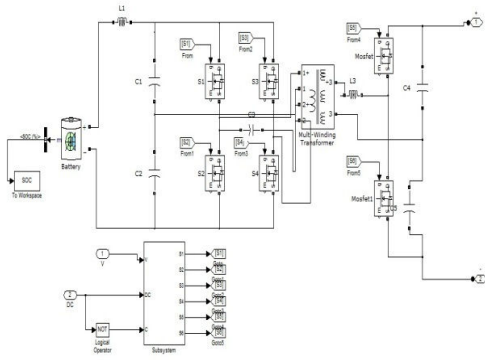

Fig. 6 Model of Bidirectional boost converter

The bidirectional boost converter is used for both battery and ultra capacitor [10]. The control strategy is used to generate the gate pulse according to the condition.

IV. SIMULATION RESULTS

A. DC Bus Power and Speed of Motor

In this paper from the signal builder three reference speeds are given to the PI controller it is shown in Fig. 7, based on the error speed the required voltage is developed by the converter.

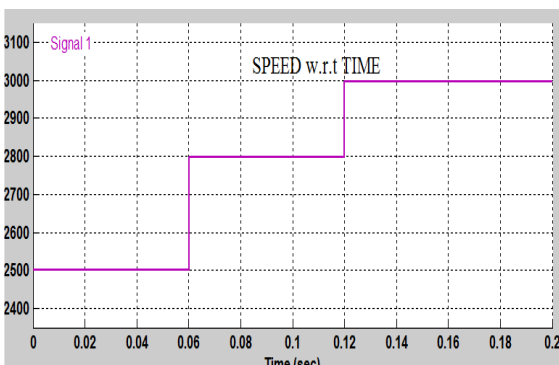

Fig. 7 Signal builder speed

The motor speed same as that of the signal builder speed it is shown in Fig. 8 Variable speed control is experimented and the waveforms are detailed. The buck converter is used to

provide the controlled voltage for variable speed condition. Fig. 9 infers the details about change of power requirement for different operating modes. The power is sensed from the buck converter is used to select whether battery or UCs sources based on the motor load conditions for HEV.

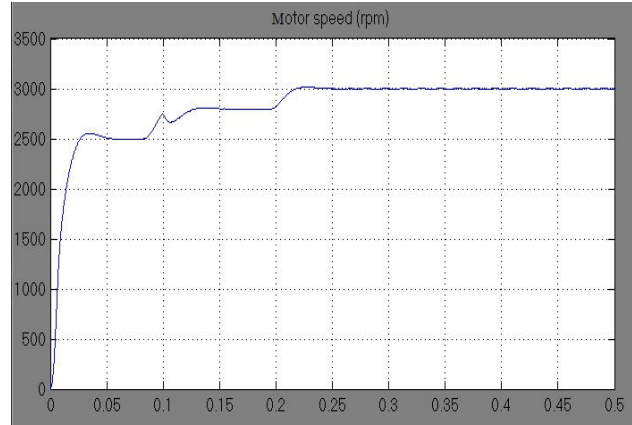

Fig. 8 Motor speed waveform

B. Battery and Ultra Capacitors

Battery discharges the stored energy by linearly and it is used in normal speed operation for HEV. When the vehicle goes beyond the speed limit the battery cannot withstand for discharging energy. During the high speed operation of the vehicle the ultra capacitor is under the process. The ultra capacitor is having sudden charging and discharge in nature within 30s. So under the condition of the environmental purpose the sources will charge the battery and ultra capacitor from the DC bus of the hybrid electric vehicle.

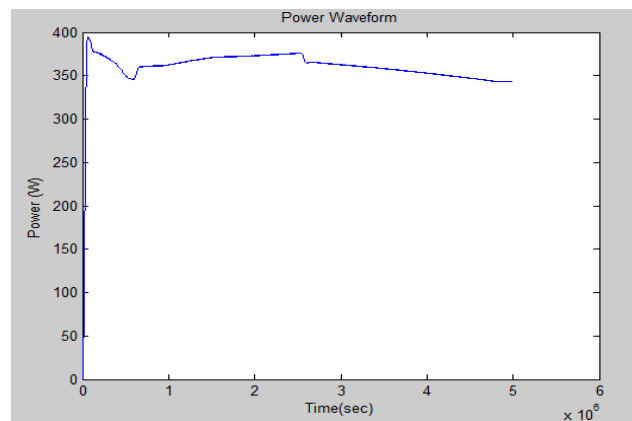

Fig. 9 Power waveform of DC bus

C. Priority of the Sources

The hybrid electric vehicle uses multiple sources for propulsion of the vehicle using a motor. The electric power is stored using two storage elements such as battery and ultra capacitor. The renewable source Fuel Cell (FC) is generating electric power according to the environmental conditions. The electric power and it is used to store energy in batteries. Each

source is acting at different conditions to make the motor of the HEV in constant speed operations.

Case 1:

The Fuel Cell is the major source for the hybrid electric vehicle using maximum power point tracking and boost converter. The generated electric power from FC is stored in the battery. If the combination of hydrogen and air is good means the generation of electric power is more efficient to run the vehicle. If the FC generating power is low means the stored energy in the battery is used for propelling the vehicle.

Case 2:

So the second battery source is will be generated the electric power for the vehicle. They generate power is used to charge the battery. The charges of the battery are also used for the propulsion of the vehicle.

Case 3:

The battery is a linear discharge device for propels the hybrid electric vehicle. During sudden high speed operation of the motor in the vehicle the battery cannot withstand that condition. In that case, the Ultra Capacitors (UCs) are used to run the vehicle for sudden high speed conditions. The UCs has high charging and discharging conditions. Due to these conditions the battery lifetime is extended and continuous operation of motor in vehicle is assured.

D. Pulse Generate

The PWM signal is generated based on the speed and current characteristic of the DC motor. The speed of the motor is compared with the reference speed signal in speed controller and it generates a reference current signal. The current from the motor is compared with the reference current signal in current controller. The gate pulse is generated for the buck converter of the HEV.

The output power of the buck converter compares with the reference power than by using the PI controller the gate pulse generates for a bidirectional converter of battery and ultra capacitors. According to the gate pulse, the battery and ultra capacitor will get charging or discharging for the speed condition of the vehicle.

V. CONCLUSION

In this paper, the power flow of several energy sources of the HEV has been presented. A hybrid arrangement, which is a parallel combination of FC, battery and UCs, is observed and their performances are studied using MATLAB/Simulink. The P&O technique is straightforward, accurate, and easy to implement for FC. Furthermore, the battery life can be improved due to decrease in the output current. A hybrid energy storage arrangement enhances the overall energy management system and a bidirectional DC/DC converter was simulated.

Future work in this area can be aimed at addressing different combinations of system to reduce the size, cost and also the switching of the converters using various other techniques.

REFERENCES

- [1] Y. Wu and H. W. Gao, "Optimization of fuel cell and supercapacitor for fuel-cell electric vehicle," *IEEE Trans. Veh. Technol.*, vol. 55, no. 6, pp. 1748–1755, Nov. 2006.
- [2] Fam, W. Z., and Balachander, M. K. "Dynamic performance of a dc shunt motor connected to photovoltaic array" *IEEE Transactions on Energy Conversion*, 3, 1988.
- [3] S.Saravanan and S. Thangavel, " Instantaneous reference current scheme based power management system for a solar/wind/ fuel cell fed hybrid power supply," *ELSEVIER.*, vol. 55, pp. 155-170, 2014.
- [4] S. M. Lukic, J. Cao, R. C. Bansal, F. Rodriguez, and A. Emadi, "Energy storage systems for automotive applications," *IEEE Trans. Ind. Electron.*, vol. 55, no. 6, pp. 2258–2267, Jun. 2008.
- [5] Wirasingha And Emad," Classification And Review Of Control Strategies For PHEVs," *IEEE Trans. Veh.Tech.*, vol. 60, no. 1, pp. 111–122, Jan.2011.
- [6] A. Lahyani, P. Venet, and A. Troudi, "Design of power sharing system between supercapacitors and battery in an uninterruptible power supply (UPS)," presented at the IEEE 33rd Int. Telecommun. Energy Conf., Amsterdam, The Netherlands, Oct. 9–13, 2011.
- [7] Dufo-López R, Bernal-Agustín JL, Contreras J. Optimization of control strategies for stand-alone renewable energy systems with hydrogen storage. *Renewable Energy* 2007;32:1102–26.conference on Power Electronics and Motion Control, pp. 1614-1619, 2006.
- [8] Z.Amjadi and S.S.Williamson, "Power-Electronic –Based Solutions for Plug-in Hybrid Electric Vehicle Energy Storage and Management Systems," *IEEE Trans. Ind. Electron.*, vol. 57, no. 2, pp. 608-616, Feb. 2010.
- [9] M.Zandi, A.Payman, J.P. Martin, S.Pierfederici and B.Davat, " Energy Management of a Fuel Cell/Supercapacitor/Battery Power Source for Electric Vehicular Applications," *IEEE Trans. Veh. Tech.*, vol. 60,no. 2, pp. 433-443, Feb.2011.
- [10] B. Zahedi, O. C. Nebb, and L. E. Norum, "An isolated bidirectional converter modeling for hybrid electric ship simulations," in *Proc. IEEE Transp. Electrification Conf. Expo.*, Jun. 2012.